



EBARA

Quality System
Quality Endorsed Company

ISO 9001 : 2000
Lic no: OEC22090

FS 8005-5 Rev. 5

TECHNICAL DATA BOOK

EBARA END SUCTION VOLUTE PUMP

MODEL FSA

SUCTION SIZE 50 ~ 250 MM

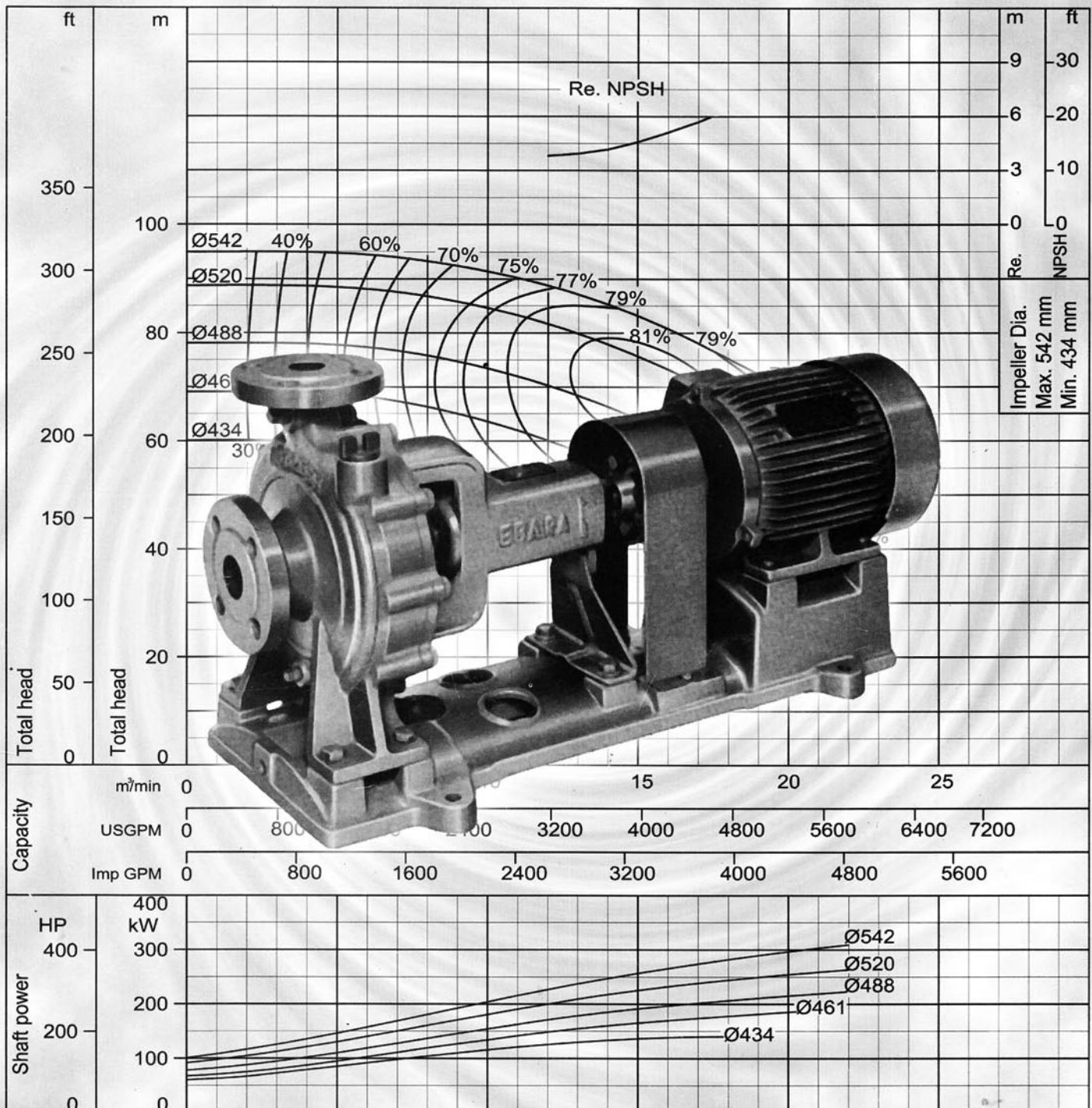

INDEX

ITEM	DISCRIPTION	PAGE
1	FEATURES AND APPLICATIONS	1
2	SELECTION CHART	2 ~ 3
3	SPECIFICATION	4
4	SECTIONAL VIEW	5 ~ 6
5	SHAFT SEAL, GASKET AND BEARING	7
6	COUPLING	8 ~ 10
7	DIMENSION - BARE SHAFT PUMP	11 ~ 12
8	DIMENSION - PUMP WITH MOTOR	13 ~ 19
9	PERFORMANCE CURVE	20 ~ 59

Note :

All specifications subject to change without prior notice

Ebara End Suction Volute Pump

Model **FSA**

Sectional View - Mechanical Seal Type (Standard)

50 Hz

Features

1. Easy removal and maintenance, BPO (Back Pull Out) system allows all rotating elements to be removed without disconnecting suction and discharge pipework.
2. Top centerline discharge, foot support under casing for maximum resistance to misalignment and distortion from pipe loads
3. Non-overload design to ensure stable performance for all applications
4. Wider range application with flow capacity up to 22 m³/min.
5. Higher working pressure up to 16 bar.

Applications

1. Industrial use
2. Water supply
3. Hot and cold water supply
4. For swimming pool
5. Sprinkling
6. Air conditioning
7. Fire-fighting application.

Ebara End Suction Volute Pump

Model FSA

Performance Chart and Model Code

50 Hz

Performance Chart - 4 Poles - 50 Hz

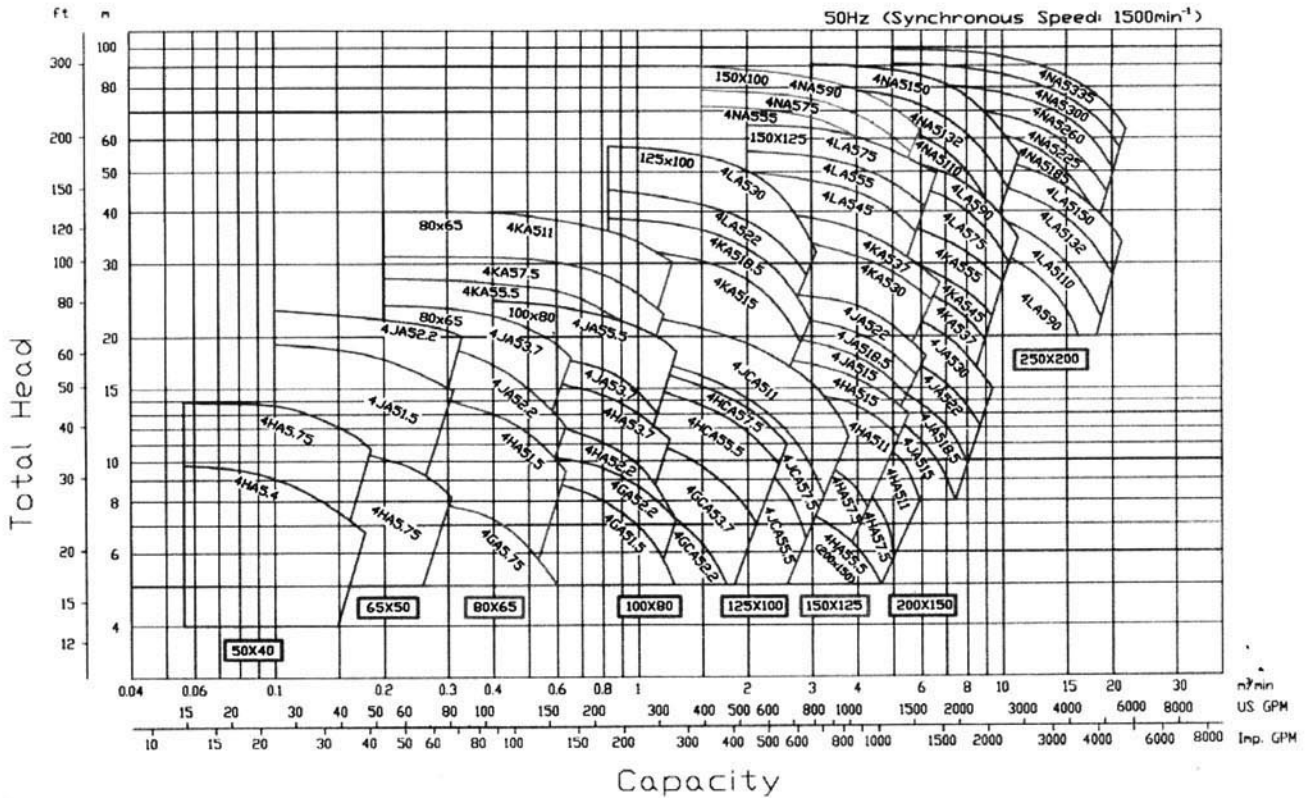

Model Code - 4 Poles - 50 Hz

16 bar version : H
10 bar version : -

50 X 40 FS 4 HA 5 .75 H

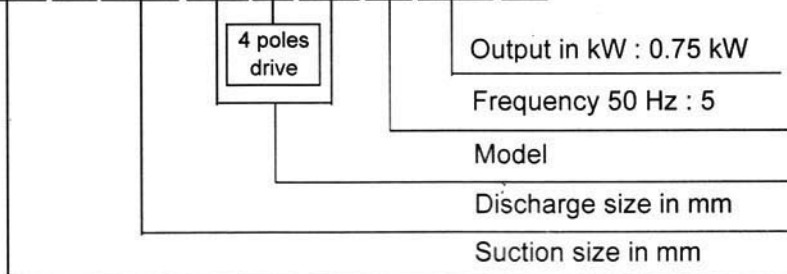

Ebara End Suction Volute Pump

Model FSA

Performance Chart and Model Code

50 Hz

Performance Chart - 2 Poles - 50 Hz

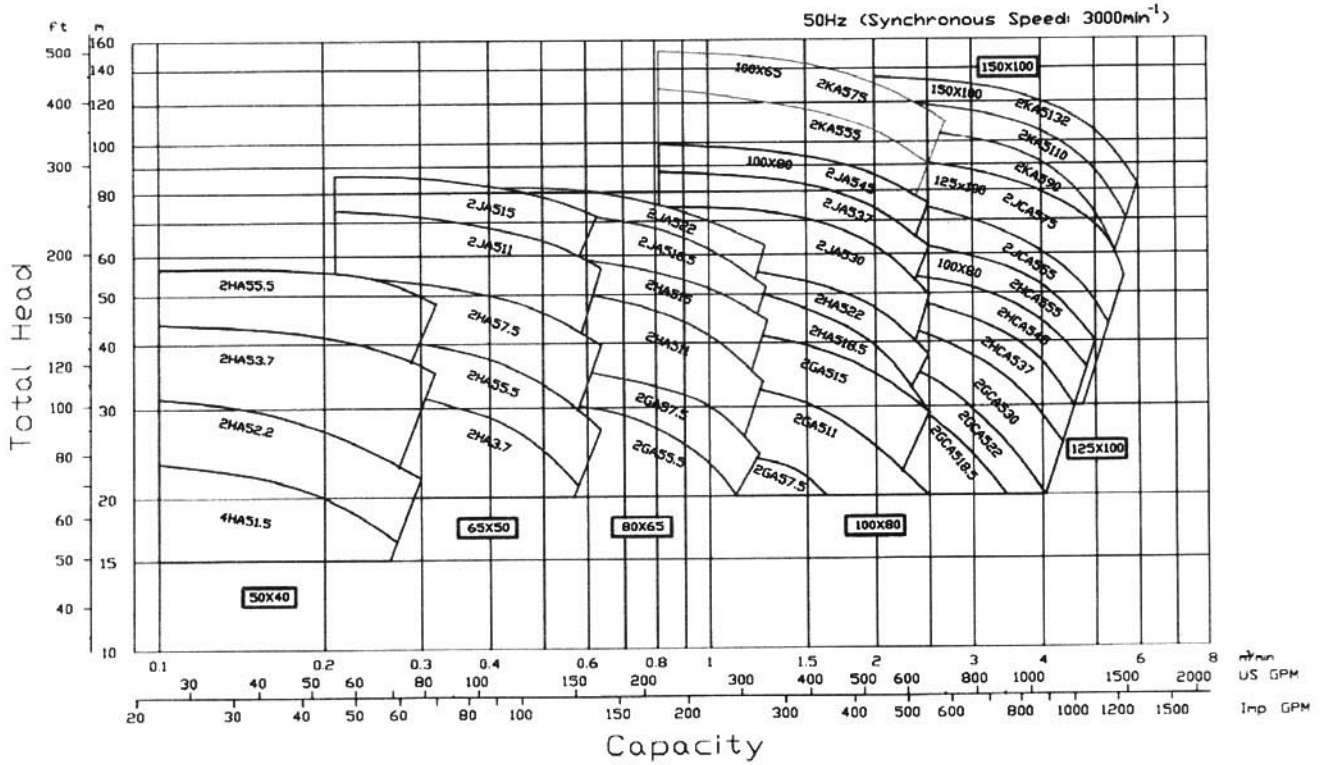

Model Code - 2 Poles - 50 Hz

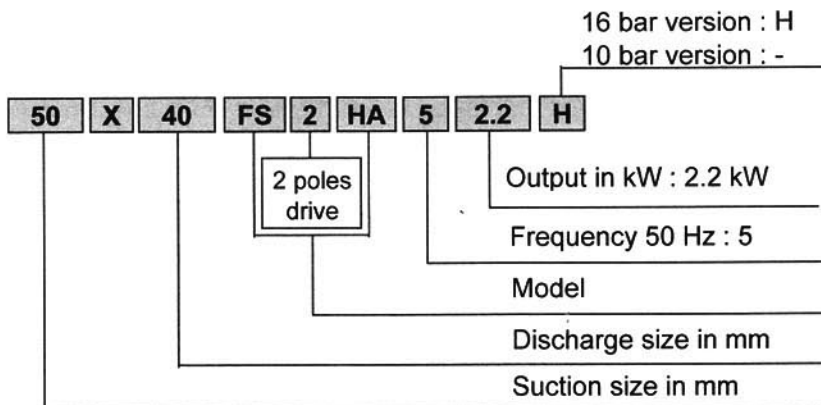

Ebara End Suction Volute Pump

Model FSA

Specifications

50 Hz

■ Pump

Description		Standard		Optional	
		2 poles model	4 poles model	2 poles model	4 poles model
Liquid	Name	Clean water			
	Temperature	0 to 80 °C (32 to 176 °F)			
Max. Working Pressure		10 bar (10.2 kgf/cm ²) for standard flange JIS 10K RF		16 bar (16.3 kgf/cm ²)	
		16 bar (16.3 kgf/cm ²) for standard flange JIS 16K RF			
Synchronous Speed		3000 min ⁻¹	1500 min ⁻¹		
Instalation		Indoors		Outdoors	
Construction	Impeller	Enclosed			
	Shaft seal	Mechanical seal		Gland Packing	
	Sealing	Self flushing		External flushing	
	Bearing	Sealed ball bearing		Oil bath (some models only)	
Flange	Suction & Discharge	Suction < φ 150 mm, except 100x65 FSKA : JIS 10K RF		16 bar : JIS 16K RF; DIN PN-16	
		100x65 FSKA : JIS 16K RF		DIN PN-16	
		Suction = φ 150 mm, except below models : JIS 10K RF		16 bar : JIS 16K RF; DIN PN-16	
		150x100 FSKA; 150x100 FSNA : JIS 16K RF		DIN PN-16	
		Suction = φ 200 mm, except below models : JIS 10K RF		16 bar : JIS 16K RF; DIN PN-16	
		200x150 FSLA; 200x150 FSNA : JIS 16K RF		DIN PN-16	
Material	Casing	Cast Iron		Ductile Cast Iron (FCD)	
	Impeller	Bronze Casting (CAC406/BC6)		Cast iron; Ductile Cast Iron (FCD)	
	Shaft	403 Stainless steel		304; 316 Stainless steel	
	Seal	Mechanical Seal: Ceramic/Carbon/NBR		Gland Packing : Teflon (PTFE) impregnated Mechanical Seal : SiC/SiC	
Accessories	Bare shaft			Priming funnel ; valve; Companion Flange	
	With motor	Common base, Coupling, Coupling guard		Priming funnel ; valve; Companion Flange	

■ Paint

Part Name	Material (JIS Code)	Standard		Optional Inner Surface
		Inner Surface	Outer Surface	
Casing	Cast Iron (FC)	1 coat of Zinc chromate primer	Under coat - 1 coat of Zinc chromate primer Finish coat	1 coat of Tar epoxy resin
Bearing Housing Bearing Cover	Cast Iron (FC)		- 1 coat of Phthalic resin enamel	
Common Base	Cast Iron (FC)	Under coat - 1 coat of Zinc chromate primer Finish coat - 1 coat of Phthalic resin enamel		
	Steel			

Ebara End Suction Volute Pump

Model FSA

Sectional View - Mechanical Seal Type (Standard)

50 Hz

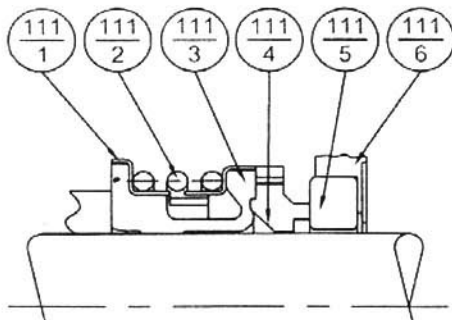
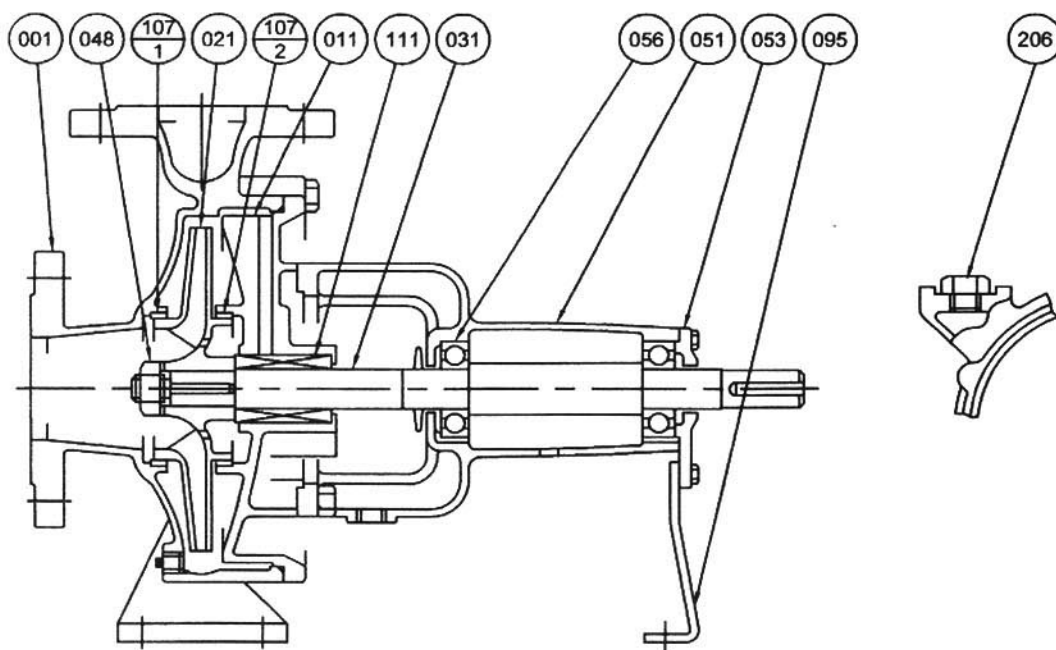

207	Plug	Steel	1
111	Mechanical Seal	-	
107-2	Casing Ring	Bronze	
107-1	Casing Ring		
095	Stay	Steel	1
056	Ball Bearing	-	2
053	Bearing Cover	Cast Iron	1
051	Bearing Housing		
048	Impeller Nut	Brass	
031	Shaft	Stainless Steel	
021	Impeller	Bronze	
011	Casing Cover	Cast Iron	
001	Casing		
No.	Part Name	Material	Qty

111-6	Cup Gasket	NBR	1
111-5	Mating Ring	Ceramic	
111-4	Seal Ring	Carbon	
111-3	Bellows	NBR	
111-2	Spring	Stainless Steel	
111-1	Spring Holder		
No.	Part Name	Material	Qty

Recommended Spare Parts			
No.	Part Name	Expected Life (year)	Qty/Unit
056	Ball Bearing	3	2
107	Casing Ring	2	2
111	Mechanical Seal	1	1
	Coupling Rubber	2	1 Set

Ebara End Suction Volute Pump

Model FSA

Sectional View - Gland Packing Type (Option)

50 Hz

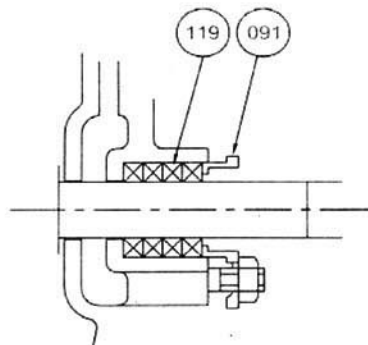
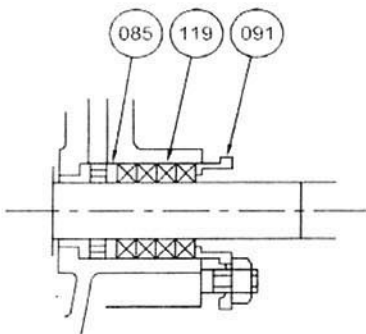
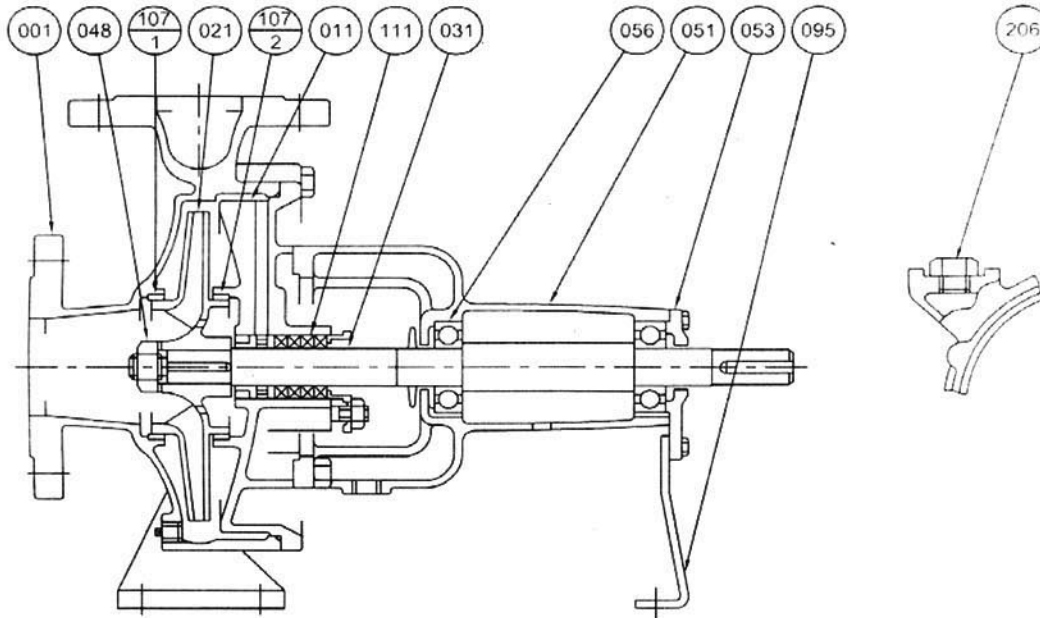

119	Gland Packing	Non-Asbestos	4 or 5
091	Gland	Bronze	1
085	Lantern Ring		
No.	Part Name	Material	Qty

119	Gland Packing	Non-Asbestos	4 or 5
091	Gland	Bronze	1
No.	Part Name	Material	Qty

207	Plug	Steel	1
111	Gland Packing	Non-Asbestos	4 or 5
107-2	Casing Ring	Bronze	1
107-1	Casing Ring		
095	Stay	Steel	1
056	Ball Bearing	-	2
053	Bearing Cover	Cast Iron	1
051	Bearing Housing		
048	Impeller Nut	Brass	
031	Shaft	Stainless Steel	
021	Impeller	Bronze	
011	Casing Cover	Cast Iron	
001	Casing		
No.	Part Name	Material	Qty

With Lantern Ring

50x40 FSHA; 65x50 FSHA, FSJA;
 80x65 FSGA, FSHA;
 100x80 FSGA; 125x100 FSLA;
 150x100 FSKA, FSNA;
 150x125 FSKA, FSLA;
 200x150 FSJA, FSLA, FSNA;
 250x200 FSLA, FSNA

Without Lantern Ring

80x65 FSJA, FSKA;
 100x65 FSKA;
 100x80 FSHA, FSJA, FSGCA, FSHCA;
 125x100 FSJCA, FSKA;
 150x125 FSHA, FSJA;
 200x150 FSHA, FSKA;

Recommended Spare Parts			
No.	Part Name	Expected Life (year)	Qty/Unit
056	Ball Bearing	3	2
107	Casing Ring	2	2
119	Gland Packings	1	1 Set
	Coupling Rubber	2	1 Set

Ebara End Suction Volute Pump

Model FSA

Shaft Seal and Gasket

50 Hz

Model	Mechanical Seal	O-Ring/ Gasket	Gland Packing Size mm	Qty of Gland Packing
50x40 FSHA	EA-262-25	Gs-225	41x25x8	4
65x50 FSHA	EA-262-25	Gs-225	41x25x8	4
65x50 FSJA		Gs-275		
80x65 FSGA	EA-262-25	Gs-180	41x25x8	4
80x65 FSHA		Gs-225		
80x65 FSJA	EA-262-35	Gs-275	51x35x8	
80x65 FSKA		Gs-335		
100x65 FSKA	EA-262-40	Gs-335	56x40x8	4
100x80 FSGA	EA-262-25	Gs-275	41X25X8	4
100x80 FSHA	EA-262-35	Gs-225	51X35X8	
100x80 FSJA		Gs-275		
100x80 FSGCA	EA-262-35	Gs-185		
100x80 FSHCA		Gs-225		
125x100 FSJCA	EA-262-40	Gs-275		56x40x8
125x100 FSKA	EA-262-35	Gs-335	51x35x8	5
125x100 FSLA	EA-262-45	Gs-425	65x45x10	4
150x100 FSKA	EA-262-50	370x320x0.8T	70x50x10	5
150x100 FSNA	EA-262-55	560x515x0.8T	75x55x10	4
150x125 FSHA	EA-262-35	Gs-225	51x35x8	4
150x125 FSJA		Gs-275		
150x125 FSKA	EA-262-45	Gs-335	65x45x10	5
150x125 FSLA		Gs-425		
200x150 FSHA	EA-262-35	Gs-225	51x35x8	5
200x150 FSJA	EA-262-45	Gs-275	65x45x10	
200x150 FSKA	EA-262-55	Gs-335	75x55x10	
200x150 FSLA		450x415x0.8T		
200x150 FSNA	EA-262-65	560x515x0.8T	90x65x12.5	5
250x200 FSLA	EA-262-65	480x440x0.8T	90x65x12.5	
250x200 FSNA	EA-262-75	615x550x0.8T	104x75x14.5	

Ebara End Suction Volute Pump

Model **FSA**

Motor and Coupling (1/3)

50 Hz

4 POLES - 1500 rpm

MODEL	MOTOR		COUPLING CLA	SHAFT DIAMETER	
	POWER	FRAME		PUMP	MOTOR
	kW	No.		φ P (mm)	φ M (mm)
50x40 FSHA	0.4	71	112	24	14
	0.75	80			19
65x50 FSHA	0.75	80	112	24	19
65x50 FSJA	1.5	90L	112	24	24
	2.2	100L	125		28
80x65 FSGA	0.75	80	112	24	19
80x65 FSHA	1.5	90L	112	24	24
80x65 FSJA	2.2	100L	140	32	28
	3.7	112M			
80x65 FSKA	5.5	132S	160	32	38
	7.5	132M			
	11	160M			
100x80 FSGA	1.5	90L	112	24	24
	2.2	100L	125		28
100x80 FSHA	2.2	100L	140	32	28
	3.7	112M			
100x80 FSJA	3.7	112M	140	32	48
	5.5	132S	160		
100x80 FSGCA	2.2	100L	140	32	28
	3.7	112M			
100x80 FSHCA	5.5	132S	160	32	38
	7.5	132M			
125x100 FSJCA	5.5	132S	160	38	38
	7.5	132M			
	11	160M			
125x100 FSKA	15	160L	160	32	42
	18.5	180M	180		48
125x100 FSLA	22	180L	180	32	48
	30	200L	200		55
150x125 FSHA	7.5	132M	160	32	38
	11	160M			42
	15	160L			48
150x125 FSJA	15	160L	160	32	42
	18.5	180M	180		48
	22	180L			
150x125 FSKA	30	200L	200	42	55
	37	225SC	224		60
150x125 FSLA	45	225MC	224	42	60
	55	250SC	250		70
	75	250MC			
150x100 FSNA	55	250SC	250	55	70
	75	250MC			
	90	280SC			280

Ebara End Suction Volute Pump

Model FSA

Motor and Coupling (1/3)

50 Hz

4 POLES - 1500 rpm (Continued)

MODEL	MOTOR		COUPLING CLA	SHAFT DIAMETER	
	POWER	FRAME		PUMP	MOTOR
	kW	No.		φ P (mm)	φ M (mm)
200x150 FSHA	5.5	132S	160	32	38
	7.5	132M			42
	11	160M			42
200x150 FSJA	15	160L	160	42	42
	18.5	180M	180		48
	22	180L	200		55
200x150 FSKA	37	225SC	224	48	60
	45	225MC			70
	55	250SC			70
200x150 FSLA	75	250MC	250	48	70
	90	280SC	280		80
	110	280MC	280		80
200x150 FSNA	132	315SC	315	60	85
	150	315MC			80
	90	280SC			280
110	280MC	315	85		
250x200 FSLA	132	315SC	315	60	
	150	315MC			80
	185	315MB			315
250x200 FSNA	225	315CB-95R	355	74	95
	260	355AB-95R			
	300	355CB-95R			
	335	355CB-95R			

Ebara End Suction Volute Pump

Model **FSA**

Motor and Coupling (3/3)

50 Hz

2 POLES - 3000 rpm

MODEL	MOTOR		COUPLING CLA	SHAFT DIAMETER	
	POWER	FRAME		PUMP	MOTOR
	kW	No.		φ P (mm)	φ M (mm)
50x40 FSHA	1.5	90S	112	24	24
	2.2	90L			
	3.7	112M			
	5.5	132S			
65x50 FSHA	3.7	112M	125	24	28
	5.5	132S			
	7.5	132S			
65x50 FSJA	11	160M	160	24	42
	15	160M			
80x65 FSGA	5.5	132S	160	24	38
	7.5	132S			
80x65 FSHA	11	160M	160	24	42
	15	160M			
80x65 FSJA	18.5	160L	160	32	42
	22	180MA			
100x80 FSGA	7.5	132S	160	24	38
	11	160M			
	15	160M			
100x80 FSHA	18.5	160L	160	32	42
	22	180MA			
100x80 FSJA	30	200LA	200	32	55
	37	200LA			
	45	225MA			
100x65 FSKA	55	250SA	224	38	60
	75	250MA			
100x80 FSGCA	18.5	160L	160	32	42
	22	180MA			
	30	200LA			
100x80 FSHCA	37	200LA	200	32	55
	45	225MA			
	55	250SA			
125x100 FSJCA	55	250SA	200	38	55
	75	250MA			
150x100 FSKA	90	280SA	250	42	65
	110	280MA			
	132	315SA			

Ebara End Suction Volute Pump

Model FSA

Dimension - Bare Shaft Pump (10 Bar Model)

50 Hz

Pump

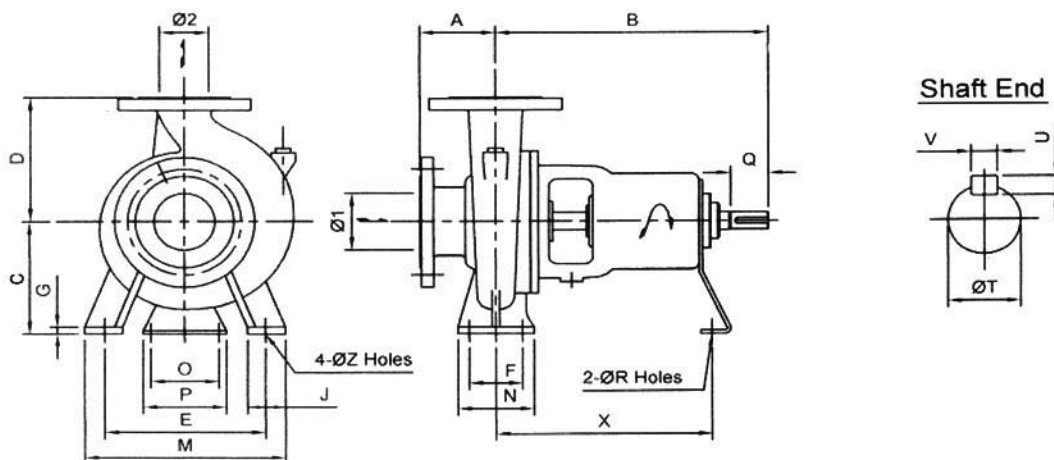

Flange

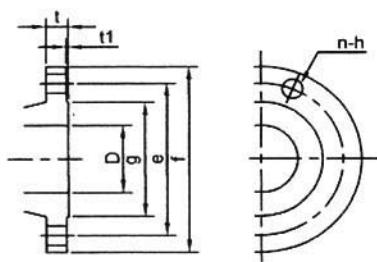

Dimension - Flange (JIS 10K RF)

D mm	f mm	e mm	g mm	t1 mm	t mm	n	h mm
40	140	105	81	2	20	4	19
50	155	120	96	2	20	4	19
65	175	140	116	2	22	4	19
80	185	150	126	2	22	8	19
100	210	175	151	2	24	8	19
125	250	210	182	2	24	8	23
150	280	240	212	2	26	8	23
200	330	290	262	2	26	12	23

Dimension - Pump

Model	Size		Pump														Shaft					wt kg
	φ1	φ2	A	B	C	D	E	F	G	J	M	N	O	P	R	X	Z	T	Q	U	V	
50x40 FSHA	50	40	80	360	160	180	190	70	12	50	240	100	110	150	17	285	15	24	50	7	8	37
65x50 FSHA	65	50	100	360	160	180	212	70	12	50	265	100	110	150	17	285	15	24	50	7	8	42
65x50 FSJA					180	225	250	95	14	65	320	125										49
80x65 FSGA					160	180	212	70	12	50	265	100						24	50	7	8	39
80x65 FSHA	80	65	100	360	160	200										285	15					48
80x65 FSJA					180	225	250	95	14	65	320	125	110	150	17							60
80x65 FSKA			125	470	225	280	315	120	16	80	400	160				370	19	32	80	8	10	108
100x80 FSGA					160	200	212	95	14	65	280	125						24	50	7	8	49
100x80 FSHA			100	360	180	225	250				320						15					62
100x80 FSJA	100	80			200	250	280	120	15	80	360	160	110	150	17	285	19					70
100x80 FSGCA					225	250					320							32	80	8	10	62
100x80 FSHCA			125	360	180	250	280	95	14	65	345	125					15					65
125x100 FSJCA				360	225	280	315	120	16	80	400	160	110	150	17	285	19	38	80	8	10	108
125x100 FSKA	125	100	140	470	250	315										370	32					128
125x100 FSLA				530	280	355	400	150	20	100	500	200					24	42	110	8	12	168
150x125 FSHA	150				250	315	315	120	15	80	400	160					19	32	80	8	10	120
150x125 FSJA		125	140	470	355				16				110	150	17	370						128
150x125 FSKA	150				280	355	400	150	16	100	500	200					24	42	110	8	12	170
150x125 FSLA					315	400			20													205
200x150 FSHA	200			470	280	355	400	150	18	100	500	200	110	150	17	370		32	80	8	10	137
200x150 FSJA		150	160		375												24	42	110	8	12	183
200x150 FSKA	200			640	315	400	450	200	20	550			140	180	19	470		48	110	9	14	222

Unit:mm, unless otherwise stated

Ebara End Suction Volute Pump

Model FSA

Dimension - Bare Shaft Pump (16 Bar Model)

50 Hz

Pump

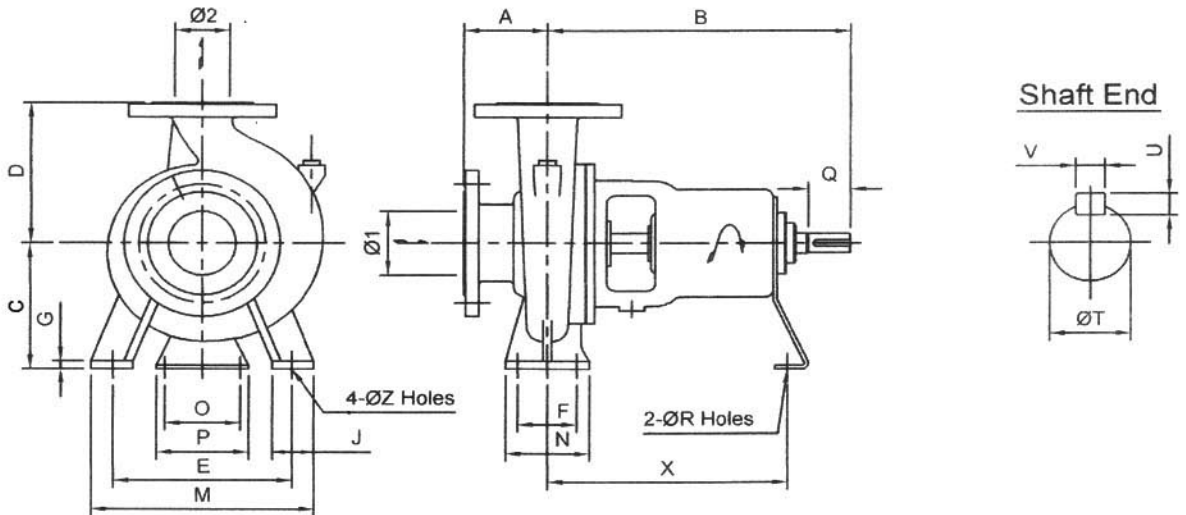

Flange

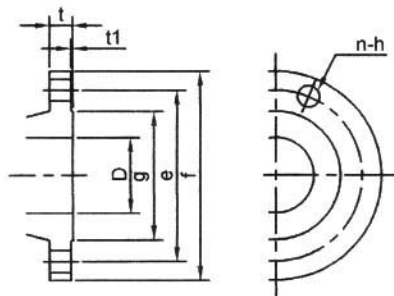

Dimension - Flange (JIS 16K RF)

D mm	f mm	e mm	g mm	t1 mm	t mm	n	h mm
65	175	140	116	2	22	8	19
100	225	185	160	2	26	8	23
150	305	260	230	2	28	12	25
200	350	305	275	2	30	12	25
250	430	380	345	2	34	12	27

Dimension - Pump

Model	Size		Pump															Shaft					wt kg
	φ1	φ2	A	B	C	D	E	F	G	J	M	N	O	P	R	X	Z	T	Q	U	V		
100x65 FSKA	100	65	125	360	225	280	315	120	16	80	400	160	110	150	17	257	19	38	80	8	10	106	
150x100 FSKA	150	100	140	530	250	315	315	120	16	80	400	160	90	120	15	373	19	42	95	8	12	146	
150x100 FSNA			180	670	375	450	450	150	20	100	550	200	140	180	19	500	24	48	110	9	14	365	
200x150 FSLA	200	150	162	670	315	450	450	150	20	100	550	200	140	180	19	500	24	48	110	9	14	336	
200x150 FSNA			182		375	560												60		11	18	488	
250x200 FSLA	250	200	180	670	385	560	560	250	25	100	660	315	140	180	19	500	24	60	110	11	18	505	
250x200 FSNA			200		820	435							630	74				125		12	20	642	

Unit:mm, unless otherwise stated

Ebara End Suction Volute Pump

Model FSA

Dimension - Pump With Motor (10 Bar Model)
4 Poles Drive - 50 Hz (1/3)

50 Hz

Pump

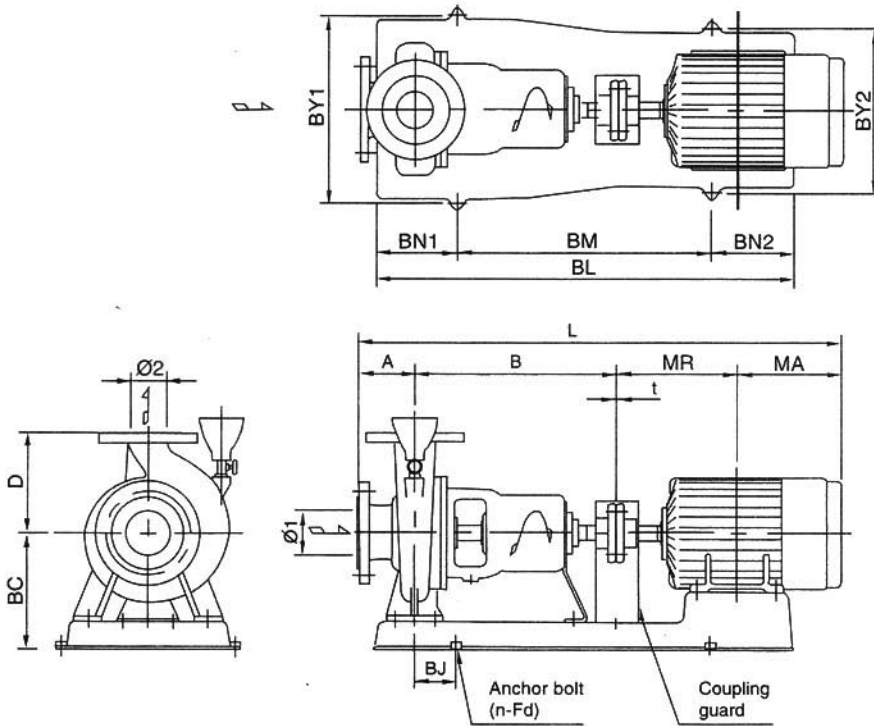

Flange

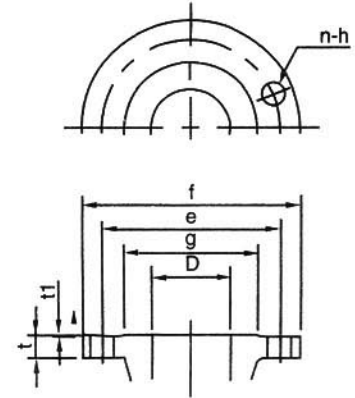

Dimension - Flange (JIS 10K RF)

D mm	f mm	e mm	g mm	t1 mm	t mm	n	h mm
40	140	105	81	2	20	4	19
50	155	120	96	2	20	4	19
65	175	140	116	2	22	4	19
80	185	150	126	2	22	8	19
100	210	175	151	2	24	8	19

Dimension - Pump

Model	Motor		Size				Pump				Motor				Common Base								Total	
	kW	φ1	φ2	A	B	D	wt kg	Frame	MR	MA	wt kg	BC	BJ	BL	BM	BN1	BN2	BY1	BY2	n-Fd	wt kg	t	L	wt kg
50x40 FS4HA	0.4	50	40	80	360	180	37	71	120	130.5	12	215	45	640	420	105	115	320	230	4-M12	19	3	693.5	71
	0.75							80	140	142.5	17										20		725.5	77
65x50 FS4HA	0.75	65	50	100	360	180	42	80	140	142.5	17	215	45	640	420	105	115	320	230	4-M12	20	3	745.5	82
65x50 FS4JA	1.5	65	50	100	360	225	49	90L	168.5	164	23.5	230	40	740	480	115	145	400	260	4-M12	24.5	3	795.5	99.5
	2.2							100L	193	181.5	32										26		837.5	110.5
80x65 FS4GA	0.75	80	65	100	360	180	39	80	140	142.5	17	215	45	640	420	105	115	320	230	4-M12	20	3	745.5	79
80x65 FS4HA	1.5	80	65	100	360	200	48	90L	168.5	164	23.5	230	40	740	550	115	75	360	290	4-M12	26	3	795.5	101
80x65 FS4JA	2.2	80	65	100	360	225	60	100L	193	181.5	32	230	40	740	480	115	145	400	260	4-M12	26	3	837.5	123
	3.7							112M	200	191.5	43								25		854.5		133	
80x65 FS4KA	5.5	80	65	125	470	280	108	132S	239	215	62	295	80	960	660	180	120	490	400	4-M16	56	3	1025	233
	7.5							132M	258	234	77										57		1090	249
	11							160M	323	285	115										57		1206	289
100x80 FS4GA	1.5	100	80	100	360	200	49	90L	168.5	164	23.5	230	40	740	550	115	75	360	290	4-M12	24	3	795.5	100
	2.2							100L	193	181.5	32										26		837.5	109
100x80 FS4HA	2.2	100	80	100	360	225	62	100L	193	181.5	32	230	40	740	480	115	145	400	260	4-M12	26	3	837.5	125
	3.7							112M	200	191.5	43			740					25		854.5		135	
100x80 FS4JA	3.7	100	80	100	360	250	70	112M	200	191.5	43	265	55	765	540	155	70	440	320	4-M16	33.5	3	854.5	151.5
	5.5							132S	239	215	62			270					855		630		350	38

Unit:mm, unless otherwise stated

Ebara End Suction Volute Pump

Model FSA

Dimension - Pump With Motor (10 Bar Model)
4 Poles Drive - 50 Hz (2/3)

50 Hz

Pump

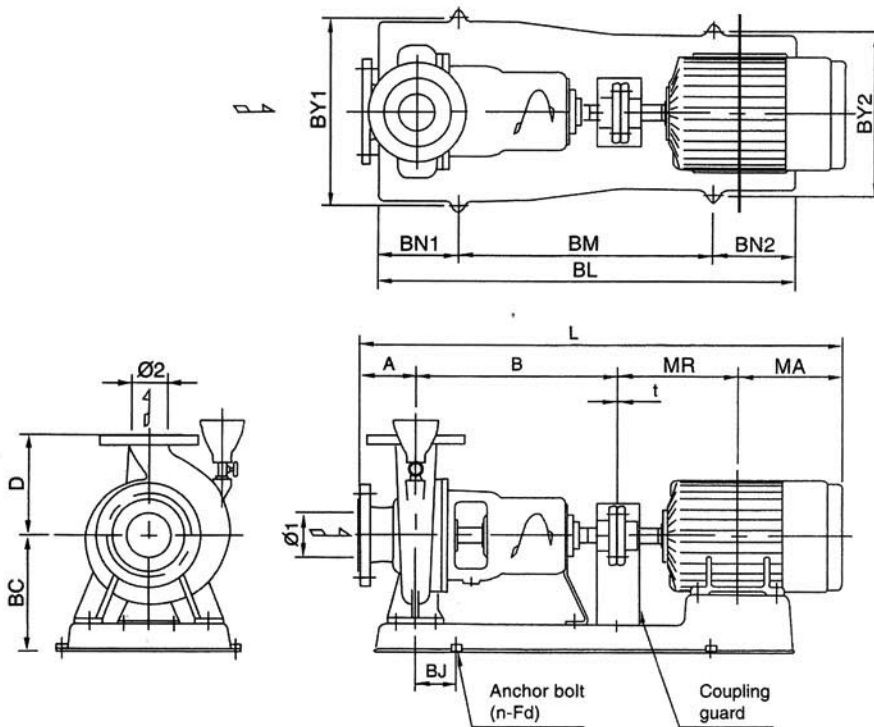

Flange

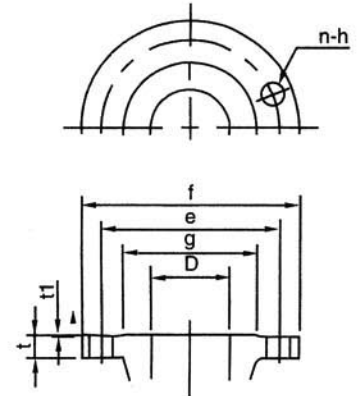

Dimension-Flange (JIS 10K RF)

D mm	f mm	e mm	g mm	t1 mm	t mm	n	h mm
80	185	150	126	2	22	8	19
100	210	175	151	2	24	8	19
125	250	210	182	2	24	8	23
150	280	240	212	2	26	8	23
200	330	290	262	2	26	12	23

Dimension - Pump

Model	Motor		Pump					Motor				Common Base								Total												
	kW	φ1	φ2	A	B	D	wt kg	Frame	MR	MA	wt kg	BC	BJ	BL	BM	BN1	BN2	BY1	BY2	n-Fd	wt kg	t	L	wt kg								
100x80 FS4GCA	2.2	100	80	125	360	225	62	100L	193	170	30	230	40	740	480	115	145	400	260	4-M12	24.5	3	851	124.5								
	112M							200	182	42	25										880		137									
100x80 FS4HCA	5.5	100	80	125	360	250	65	132S	239	207	65	250	55	855	630	155	70	440	350	4-M12	38	3	934	179								
	132M							258	234	77	40										980		193									
125x100 FS4JCA	5.5	125	100	140	360	280	108	132S	239	207	65	321	45	825	525	150	70	440	350	4-M12	55	3	949	233								
	7.5							132M	258	226	76			940	640						987		255									
	11							160M	323	281	120			60	1107						298											
125x100 FS4KA	15	125	100	140	470	315	128	160L	345	307	132	330	100	1075	740	190	145	490	400	4-M16	64.5	3	1265	331.5								
	18.5							180MC	351.5	320.5	172			84	1285						393											
125x100 FS4LA	22	125	100	140	530	355	168	180LC	370.5	339.5	205	390	95	1230	840	205	185	600	440	4-M20	86.5	3	1383	459.5								
	30							200LC	395.5	374.5	278		120	1280	940	230	110		490		86.5		4	1444	532.5							
150x125 FS4HA	7.5	150	125	140	470	315	120	132M	258	234	77	320	80	960	660	180	120	490	400	4-M16	57	3	1105	261								
	11							160M	323	285	115			330	1075	740	190				145		44.7	1221	286.5							
	15							160L	345	307	132			320	1090	200	150				62		1265	321								
150x125 FS4JA	15	150	125	140	470	355	128	160L	345	307	132	320	100	1090	740	200	150	490	400	4-M16	62	3	1265	329								
	18.5							180MC	351.5	320.5	172			330	1075	190	145				83		1285	392								
	22							180LC	370.5	339.5	205			340	1425	960	230				235		670	600	4-M20	105	1323	447				
150x125 FS4KA	30	150	125	140	530	355	170	200LC	395.5	374.5	278	390	120	1280	940	230	110	600	490	4-M20	72.4	4	1444	534.5								
	37							225SC	432	384	327			385	110	1425	960	235	670		600		141.6	1490	657							
150x125 FS4LA	45	150	125	140	530	400	205	225MC	444.5	396.5	351	395	110	1425	960	230	235	670	600	4-M20	108	4	1515	682.5								
	55							250SC	463.5	419	475										410		110	1425	960	230	235	670	600	110	1556.5	817
	75							250MC	482.5	438	550										410		109	1594.5	891							

Unit:mm, unless otherwise stated

Ebara End Suction Volute Pump

Model FSA

Dimension - Pump With Motor (10 Bar Model)
4 Poles Drive - 50 Hz (3/3)

50 Hz

Pump

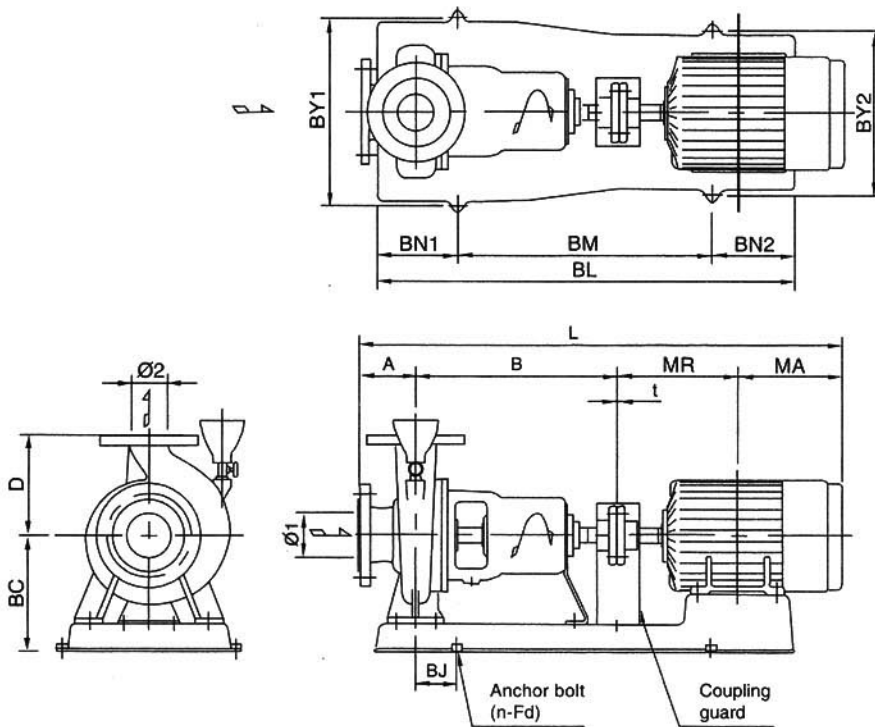

Flange

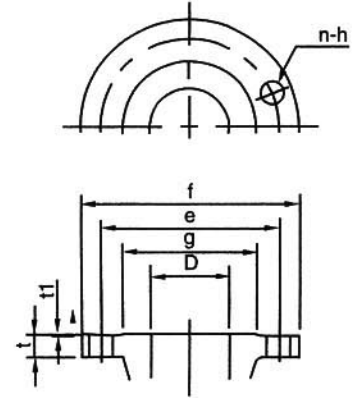

Dimension - Flange (JIS 10K RF)

D	f	e	g	t1	t	n	h
mm	mm	mm	mm	mm	mm		mm
150	280	240	212	2	26	8	23
200	330	290	262	2	26	12	23

Dimension - Pump

Model	Motor		Pump					Motor				Common Base								Total				
	kW	φ1	φ2	A	B	D	wt kg	Frame	MR	MA	wt kg	BC	BJ	BL	BM	BN1	BN2	BY1	BY2	n-Fd	wt kg	t	L	wt kg
200x150 FS4HA	5.5	200	150	160	470	355	137	132S	239	215	62	390	80	980	660	200	120	600	400	4-M16	78	3	1087	284
	7.5							132M	258	234	77												1125	299
	11							160M	323	285	115												360	1190
200x150 FS4JA	15	200	150	160	530	375	183	160L	345	307	132	390	95	1230	840	200	150	600	400	4-M16	104	3	1345	426
	18.5							180MC	351.5	320.5	172												1365	441.5
	22							180LC	370.5	339.5	205												1403	474.5
	30							200LC	395.5	374.5	278												1464	547.5
	37							225SC	432	384	327												1510	669.7
200x150 FS4KA	37	200	150	160	670	400	222	225SC	432	384	327	425	110	1460	1000	230	230	670	550	4-M20	141	4	1650	708.5
	45							225MC	444.5	396.5	351												1675	732.5
	55							250SC	463.5	419	475												1716.5	860

Unit:mm, unless otherwise stated

Ebara End Suction Volute Pump

Model FSA

Dimension - Pump With Motor (16 Bar Model)
4 Poles Drive

50 Hz

Pump

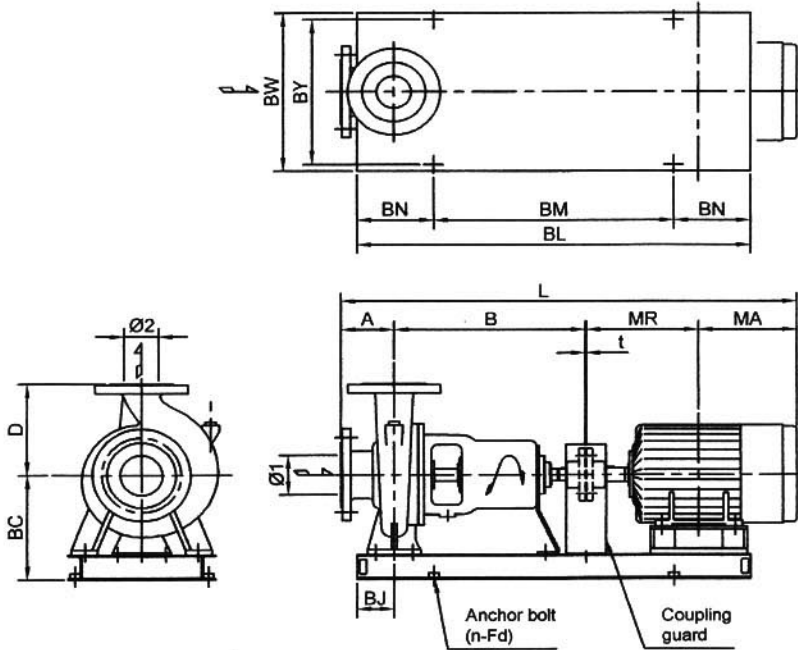

Flange

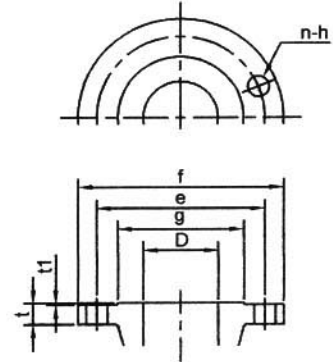

Dimension - Flange (JIS 16K RF)

D	f	e	g	t1	t	n	h
mm	mm	mm	mm	mm	mm		mm
100	225	185	160	2	26	8	23
150	305	260	230	2	28	12	25
200	350	305	275	2	30	12	25
250	430	380	345	2	34	12	27

Dimension - Pump (Steel baseplate)

Model	Motor		Pump					Motor				Common Base								Total				
	kW	φ1	φ2	A	B	D	wt kg	Frame	MR	MA	wt kg	BC	BJ	BL	BM	BN1	BN2	BY1	BY2	n-Fd	wt kg	t	L	wt kg
150x100 FSNA	55	150	100	180	670	450	365	250SC	463.5	409	520	525	130	1500	2x600	150	150	580	640	6-M20	156	4	1736.5	1030
	250MC							482.5	428	580	1530			2x615	170						1774.5		1120	
	280SC							544.0	478	660	1600			2x650	175						1876		1250	
200x150 FSNA	75	200	150	162	670	450	336	250MC	482.5	428	580	465	130	1530	2x615	150	150	580	640	6-M20	150	4	1756.5	1070
	280SC							544.0	478	660	1600			2x650	145						1858		1191	
200x150 FSNA	110	200	150	182	670	560	488	280MC	569.5	502.5	720	525	130	1670	2x685	150	150	580	640	6-M20	176	4	1928	1434
	315SC							589	527	920	1680			2x690	200						1972		1677	
	315MC							614.5	552.5	1030	1730			2x715	220						2023		1804	
250x200 FSNA	90	250	200	180	670	560	505	280SC	544.0	478	660	560	185	1680	2x675	165	165	690	760	6-M22	250	4	1876	1462
	280MC							569.5	502.5	720	1730			2x700	255						1926		1528	
	315SC							589	527	920	1740			2x705	235						1970		1725	
	315MC							614.5	552.5	1030	1790			2x730	240						2021		1841	
250x200 FSNA	185	250	200	200	200	820	630	315MB	614.5	552.5	1070	610	185	1950	2x800	175	175	690	760	6-M22	290	4	2191	2067
	315CB							741.0	1116	1800	2240			2x945	340						2881		2850	
	355AB							779.0	1200	2400	2300			2x975	330						3004		3467	
	355CB							874.0	1295	2700	2490			2x1070	365						3194		3802	

Unit:mm, unless otherwise stated

Ebara End Suction Volute Pump

Model FSA

Dimension - Pump With Motor (10 Bar Model)
2 Poles Drive (1/2)

50 Hz

Pump

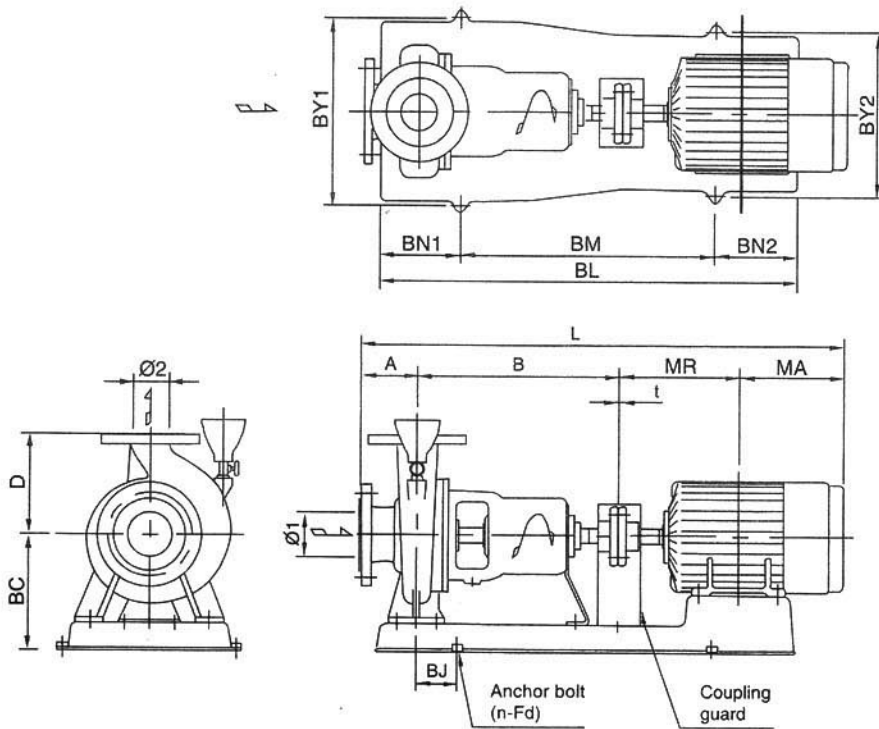

Flange

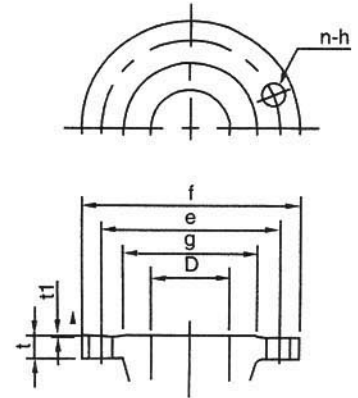

Dimension - Flange (JIS 10K RF)

D mm	f mm	e mm	g mm	t1 mm	t mm	n	h mm
40	140	105	81	2	20	4	19
50	155	120	96	2	20	4	19
65	175	140	116	2	22	4	19
80	185	150	126	2	22	8	19

Dimension - Pump

Model	Motor		Pump				Motor				Common Base								Total										
	kW	φ1	φ2	A	B	D	wt kg	Frame	MR	MA	wt kg	BC	BJ	BL	BM	BN1	BN2	BY1	BY2	n-Fd	wt kg	t	L	wt kg					
50X40 FS2HA	1.5	50	40	80	360	180	37	90S	156	151.5	21.5	220	40	740	550	115	75	360	290	4-M12	26	3	750.5	87.5					
	2.2							90L	168.5	164	26.5										29		775.5	95.5					
	3.7							112M	200	191.5	44										215		130	70	350	290	23	834.5	108
	5.5							132S	239	215	65										230		55	820	540	130	150	350	350
65X50 FS2HA	3.7	65	50	100	360	180	42	112M	200	191.5	44	215	55	740	540	130	70	350	290	4-M12	24	3	851.5	114					
	5.5							132S	239	215	65										230		32	146					
	7.5							132S	239	215	70										230		34	917	151				
65X50 FS2JA	11	65	50	100	360	225	49	160M	323	285	107	270	98	920	600	160	160	400	400	4-M16	69	3	1071	232					
	15							160M	323	285	122										122		247						
80X65 FS2GA	5.5	80	65	100	360	180	39	132S	239	215	65	230	55	820	540	130	150	350	350	4-M12	33	3	917	144					
	7.5							132S	239	215	70										70		149						
80X65 FS2HA	11	80	65	100	360	200	48	160M	323	285	107	250	98	920	600	160	160	400	400	4-M16	69	3	1071	231					
	15							160M	323	285	122										122		246						
80X65 FS2JA	18.5	80	65	100	360	225	60	160L	345	307	138	270	98	920	600	160	160	400	400	4-M16	69	3	1115	274					
	22							180M	351.5	320.5	180										180		1135	321					

Unit:mm, unless otherwise stated

Ebara End Suction Volute Pump

Model FSA

Dimension - Pump With Motor (10 Bar Model)
2 Poles Drive (2/2)

50 Hz

Pump

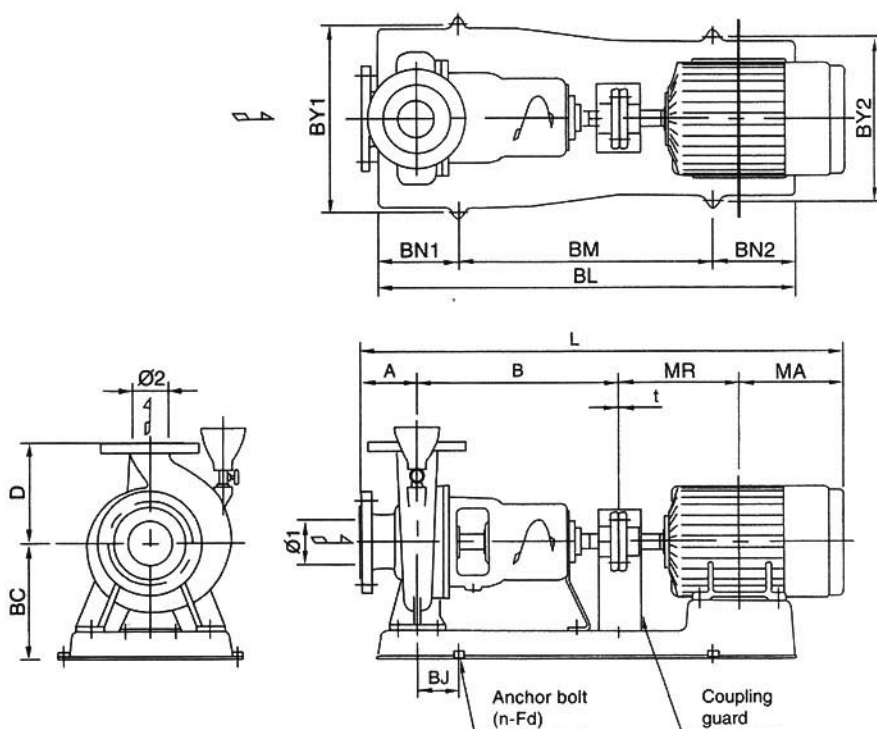

Flange

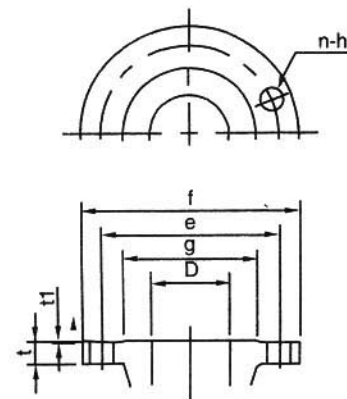

Dimension - Flange (JIS 10K RF)

D mm	f mm	e mm	g mm	t1 mm	t mm	n	h mm
80	185	150	126	2	22	8	19
100	210	175	151	2	24	8	19
125	250	210	182	2	24	8	23

Dimension - Pump

Model	Motor		Size					Pump				Motor				Common Base								Total	
	kW	φ1	φ2	A	B	D	wt kg	Frame	MR	MA	wt kg	BC	BJ	BL	BM	BN1	BN2	BY1	BY2	n-Fd	wt kg	t	L	wt kg	
100X80 FS2GA	7.5	100	80	100	360	200	49	132S	239	207	65	230	55	820	540	130	150	350	350	4-M12	30	3	909	144	
	11							160M	323	281	120	250	98	920	600	160	160	400	400	4-M16	47		1067	216	
	15							160M	323	281	120	250	98	920	600	160	160	400	400	4-M16	47		1067	216	
100X80 FS2HA	18.5	100	80	100	360	225	62	160L	345	303	158	270	98	920	600	160	160	400	400	4-M16	47	3	1111	267	
	22							170M	351.5	315.5	180												1130	289	
100X80 FS2JA	30	100	80	100	360	250	70	200L	395.5	372.5	290	275	95	1040	660	185	195	440	440	4-M16	65	4	1232	425	
	37							200L	395.5	372.5	290												1270	490	
	45							225MA	414.5	391.5	355												1270	490	
100X80 FS2GCA	18.5	100	80	125	360	225	62	160L	345	303	158	270	98	920	600	160	160	400	400	4-M16	47	4	1137	267	
	22							180MA	351.5	320.5	185												1160	294	
	30							200LA	395.5	374.5	270												1259	398	
100X80 FS2HCA	37	100	80	125	360	250	65	200LA	395.5	372.5	290	275	95	1040	660	185	195	440	440	4-M16	65	4	1259	420	
	45							225MA	414.5	396.5	343												1300	473	
	55							250SA	463.5	419	452												1257	587	
125X100 FS2JCA	55	125	100	140	360	280	108	250SA	463.5	419	452	275	95	1040	660	185	195	440	440	4-M20	65	4	1387	625	
	75							250MA	482.5	438	525												1365	733	

Unit:mm, unless otherwise stated

Ebara End Suction Volute Pump

Model FSA

Dimension - Pump With Motor (16 Bar Model)
2 Poles Drive

50 Hz

Pump

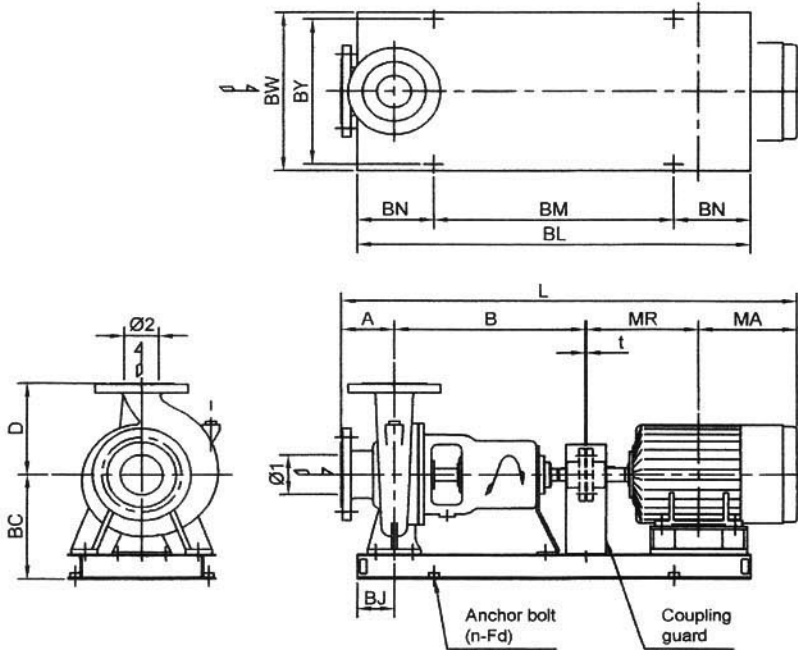

Flange

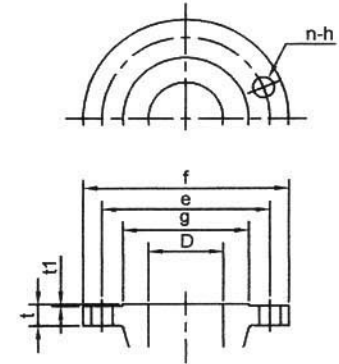

Dimension - Flange (JIS 16K RF)

D mm	f mm	e mm	g mm	t1 mm	t mm	n	h mm
65	175	140	116	2	22	8	19
100	225	185	160	2	26	8	23
150	305	260	230	2	28	12	25

Dimension - Pump (Steel baseplate)

Model	Motor		Pump					Motor				Common Base								Total								
	kW	φ1	φ2	A	B	D	wt kg	Frame	MR	MA	wt kg	BC	BJ	BL	BM	BN1	BN2	BY1	BY2	n-Fd	wt kg	t	L	wt kg				
100X65 FS2KA	55	100	65	125	360	280	49	250SA	463.5	419	452	395	50	1190	770	175	245	540	600	4-M20	95	4	1371.5	614.5				
	250MA							482.5	438	525	65													1220	850	195	1409.5	692.5
150x100 FS2KA	90	150	100	140	530	315	62	280SA	514	478	600	430	125	1430	960	235	235	640	4-M20	115	4	1666	827					
	280MA							539.5	502.5	700	145												1480	260	260	130	1716	942
	315SA							559	527.0	920	490												155	1500	270	270	650	720

Unit:mm, unless otherwise stated

Ebara End Suction Volute Pump

Model FSA

Performance Curve 4 Poles (1/27)

50 Hz

50X40 FS4HA	According to ISO testing code 2548 Class C
50Hz (Approx. speed 1450min ⁻¹)	S.G.= 1.0 Vis.= 1.0 cSt

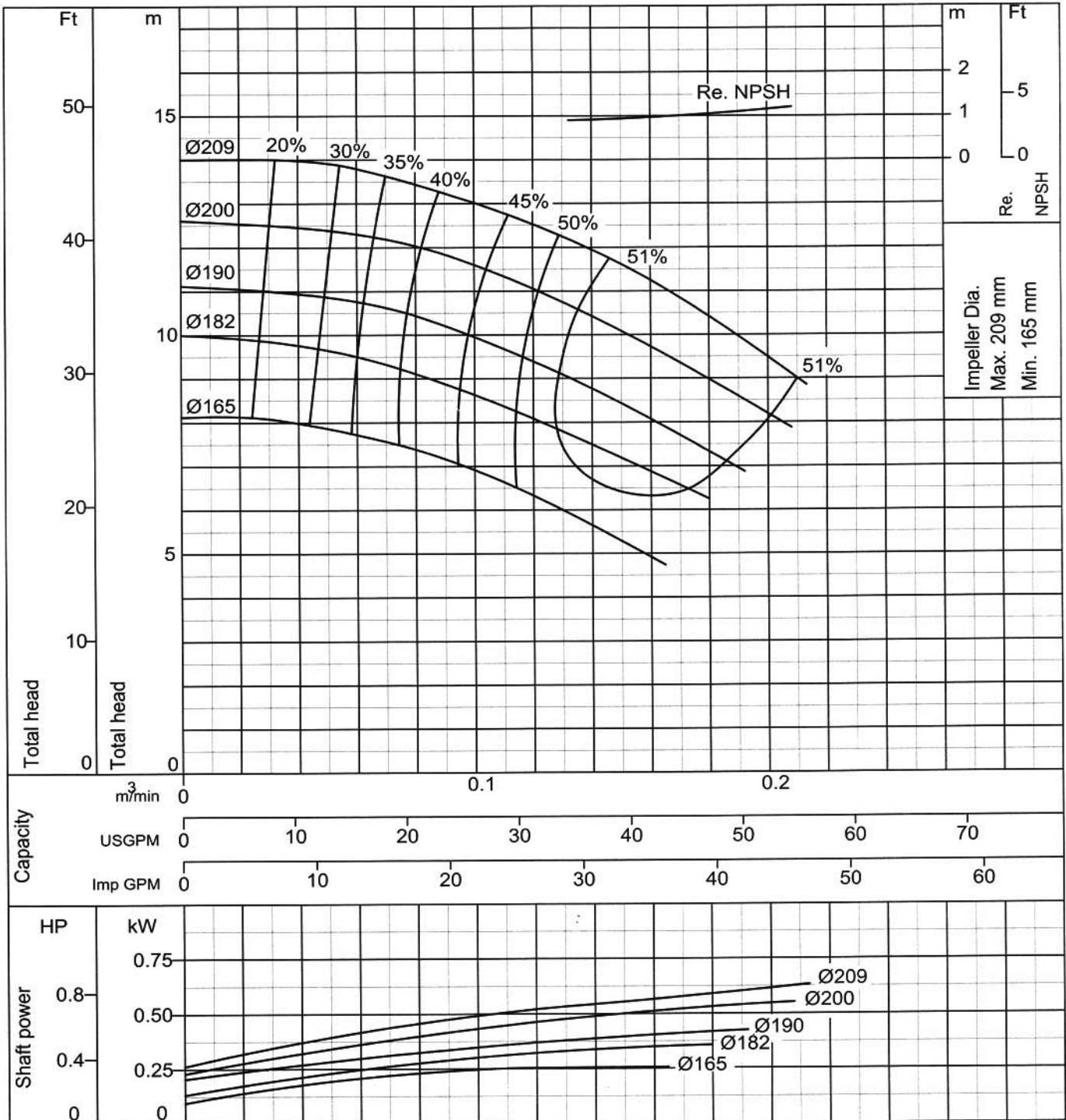

Curve No - 4 - 5FS5601R1

Ebara End Suction Volute Pump

Model FSA

Performance Curve 4 Poles (2/27)

50 Hz

65X50 FS4HA	According to ISO testing code 2548 Class C
50Hz (Approx. speed 1450min ⁻¹)	S.G.= 1.0 Vis.= 1.0 cSt

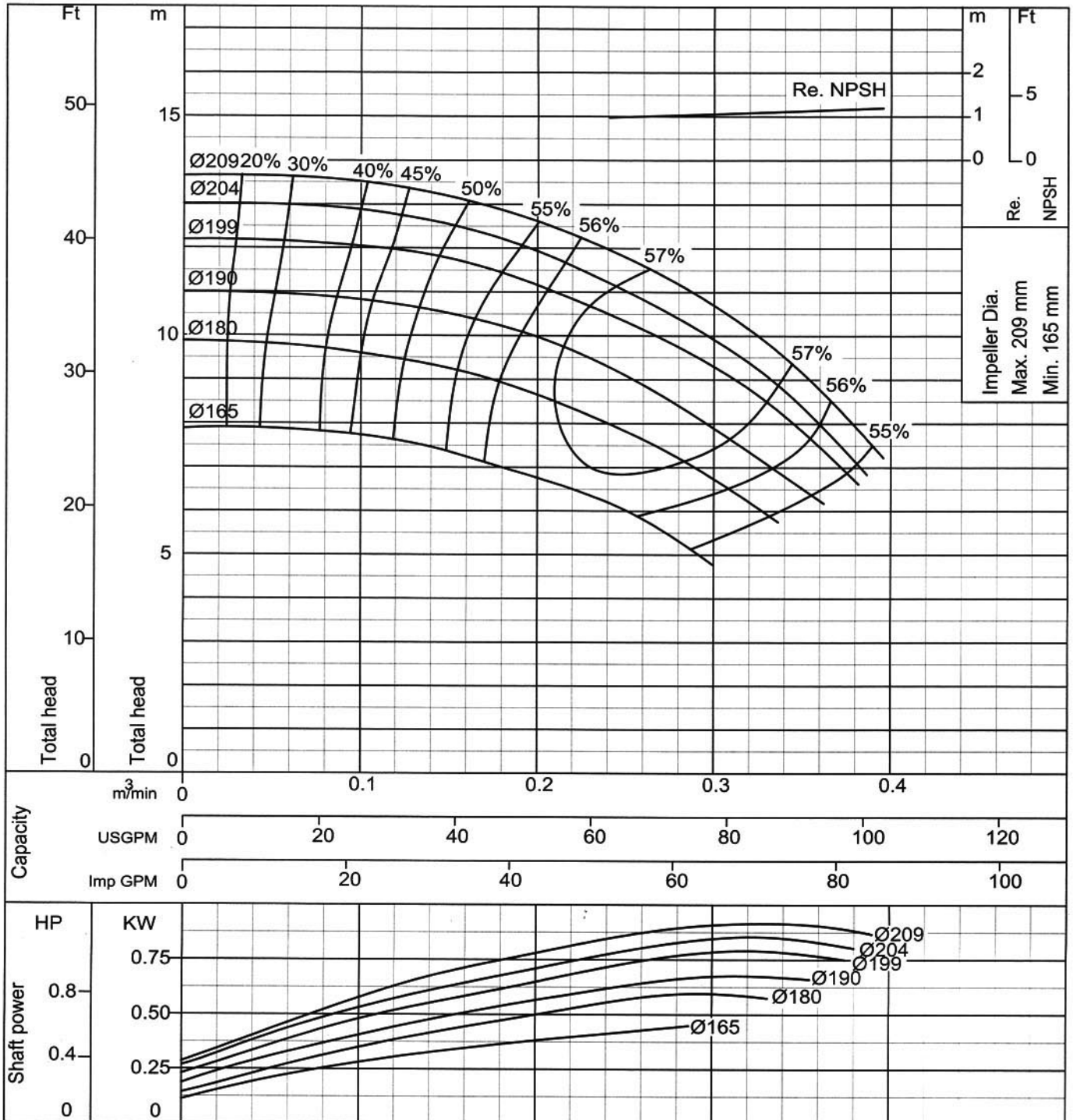

Curve No - 4 - 5FS5602R1

Ebara End Suction Volute Pump

Model FSA

Performance Curve 4 Poles (3/27)

50 Hz

65X50 FS4JA	According to ISO testing code 2548 Class C
50Hz (Approx. speed 1450min ⁻¹)	S.G.= 1.0 Vis.= 1.0 cSt

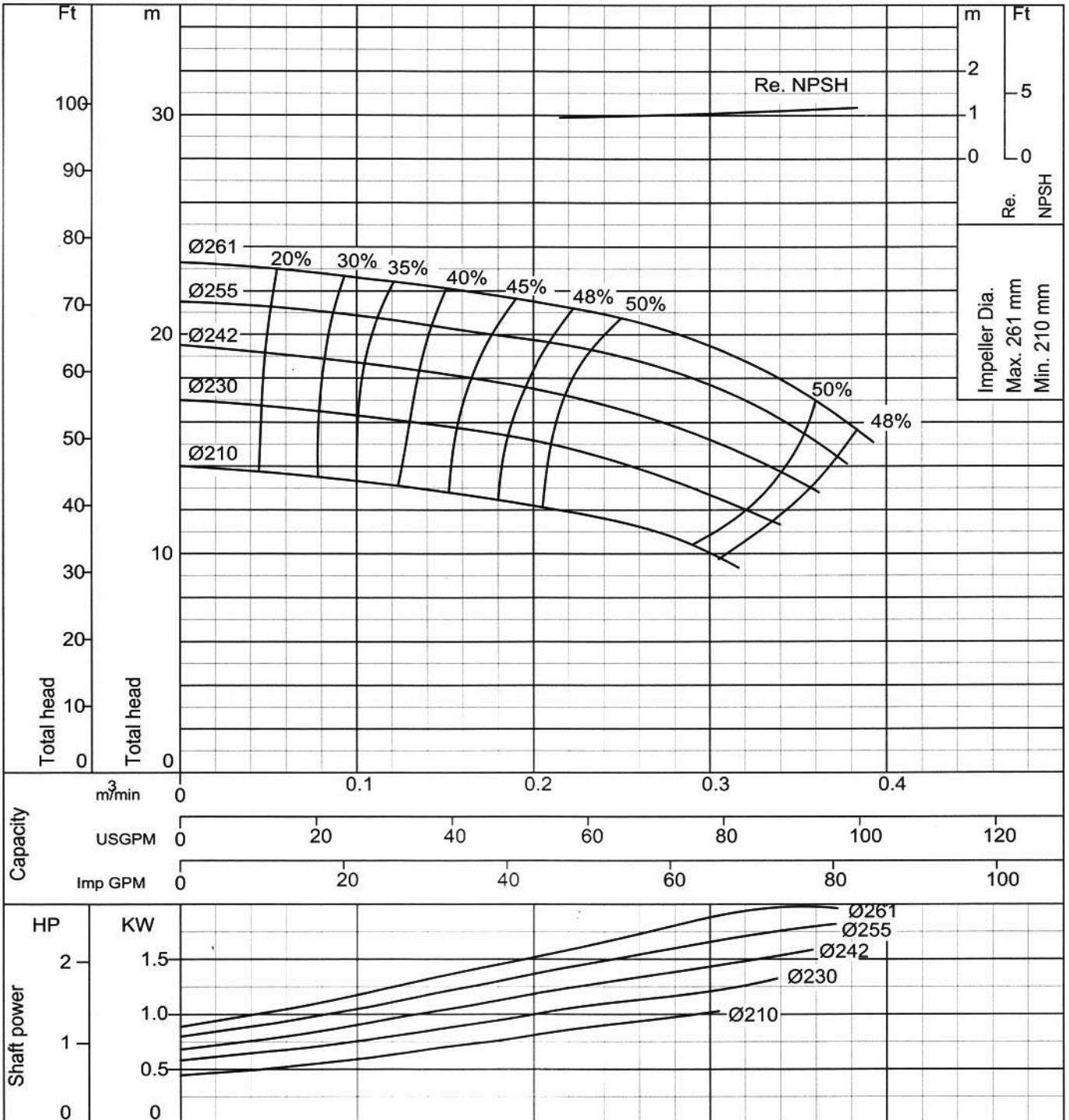

Curve No - 4 - 5FS5603R1

Ebara End Suction Volute Pump

Model FSA

Performance Curve 4 Poles (4/27)

50 Hz

80X65 FS4GA	According to ISO testing code 2548 Class C
50Hz (Approx. speed 1450min ⁻¹)	S.G.= 1.0 Vis.= 1.0 cSt

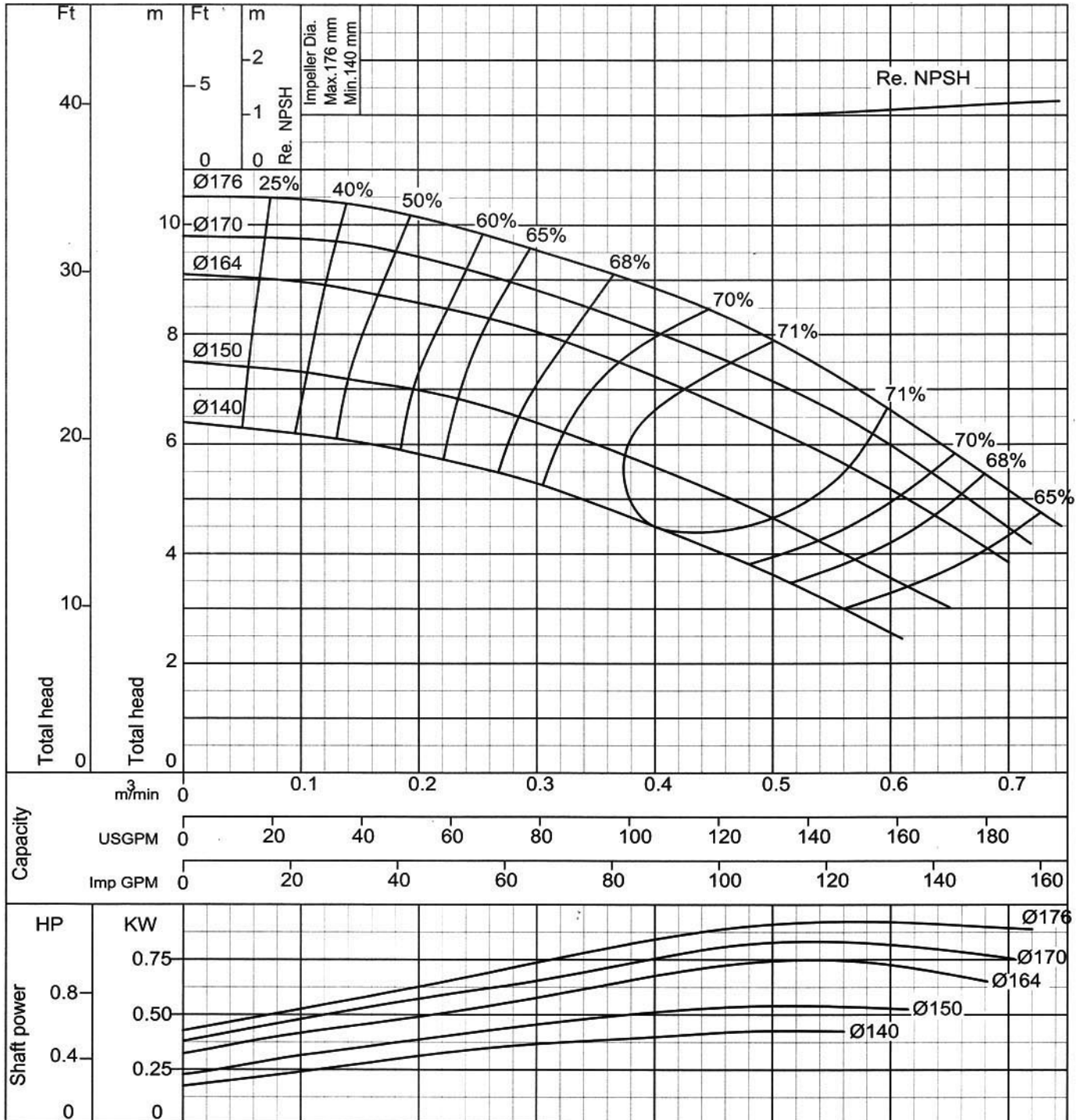

Curve No - 4 - 5FS5604R1

Ebara End Suction Volute Pump

Model FSA

Performance Curve 4 Poles (5/27)

50 Hz

80X65 FS4HA	According to ISO testing code 2548 Class C
50Hz (Approx. speed 1450min ⁻¹)	S.G.= 1.0 Vis.= 1.0 cSt

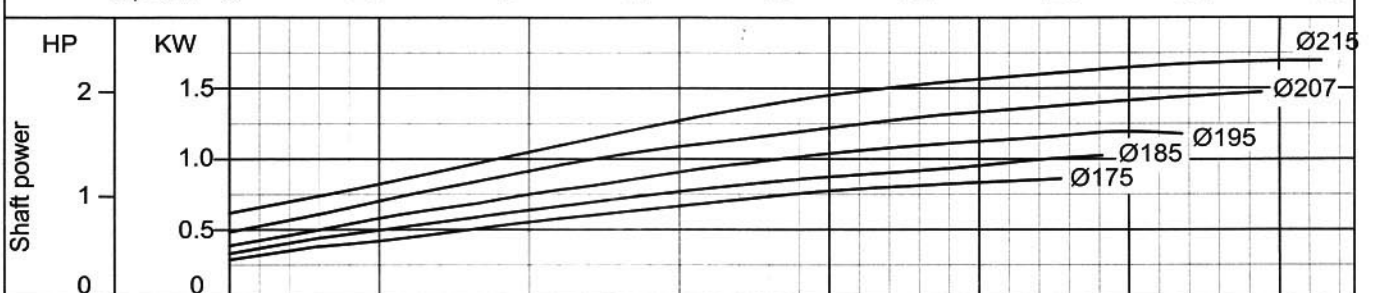
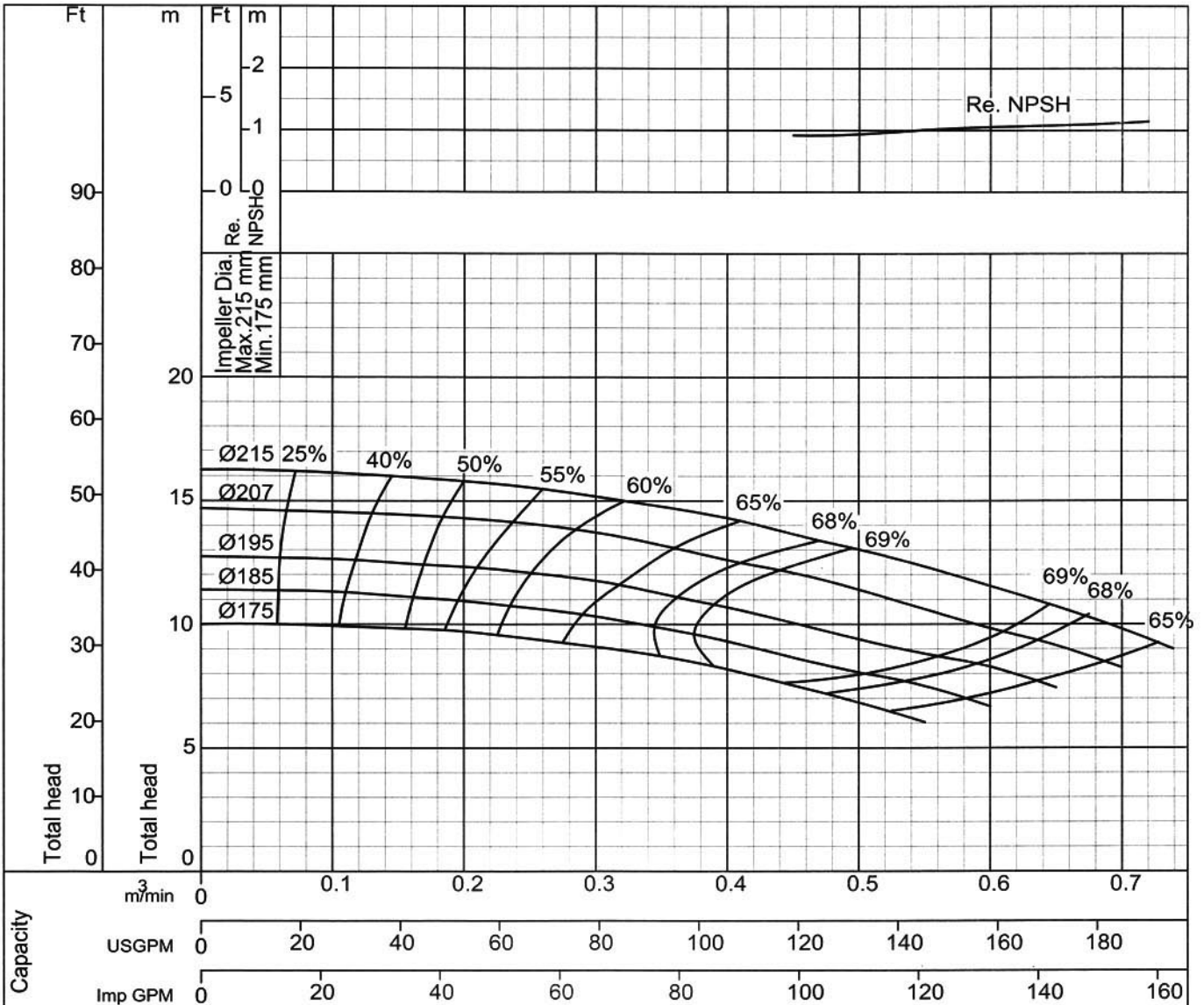

Curve No - 4 - 5FS5605R1

Ebara End Suction Volute Pump

Model FSA

Performance Curve 4 Poles (6/27)

50 Hz

80X65 FS4JA	According to ISO testing code 2548 Class C
50Hz (Approx. speed 1450min ⁻¹)	S.G.= 1.0 Vis.= 1.0 cSt

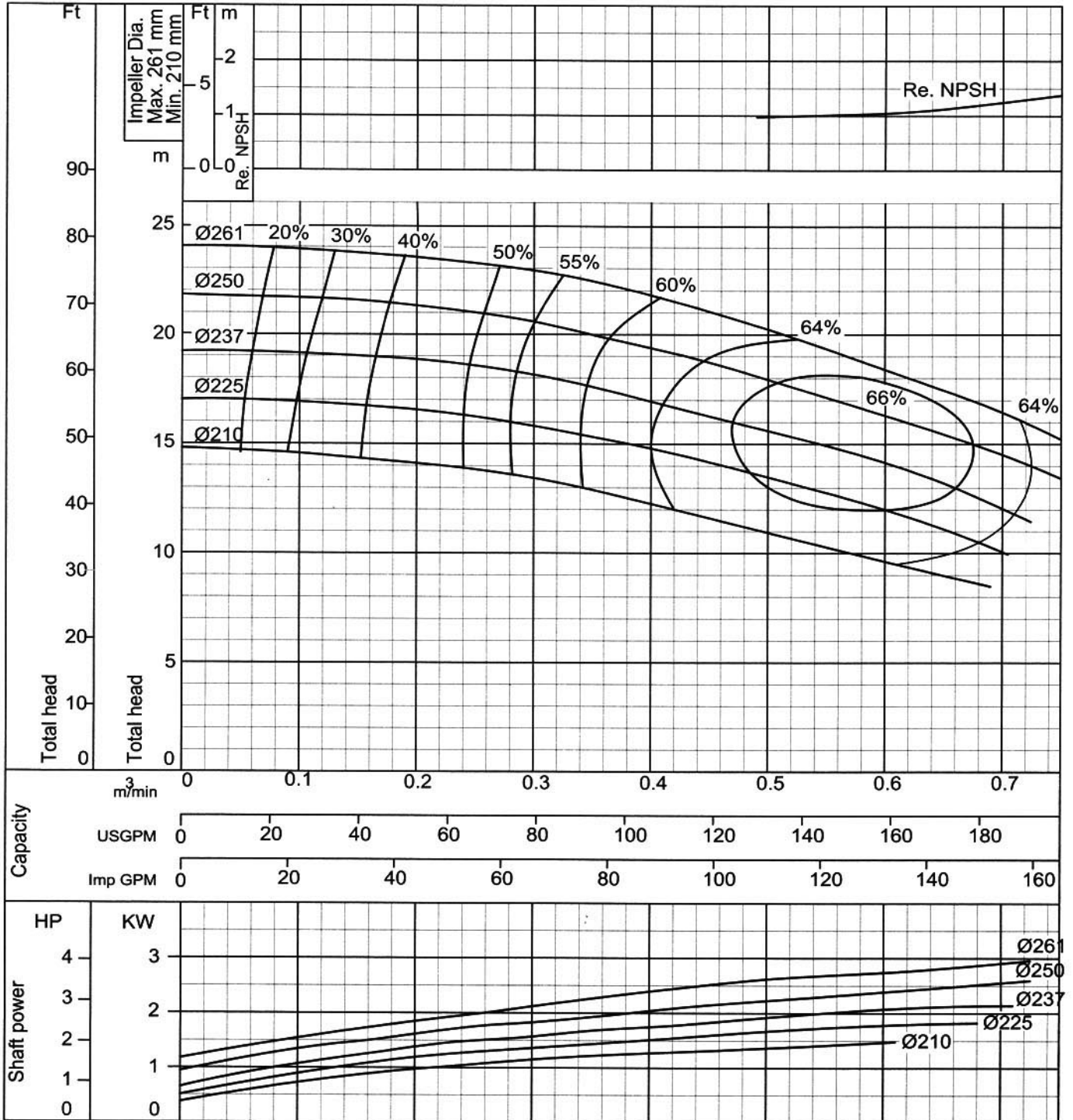

Curve No - 4 - 5FS5606R1

Ebara End Suction Volute Pump

Model FSA

Performance Curve 4 Poles (7/27)

50 Hz

80X65 FS4KA	According to ISO testing code 2548 Class C
50Hz (Approx. speed 1450min ⁻¹)	S.G.= 1.0 Vis.= 1.0 cSt

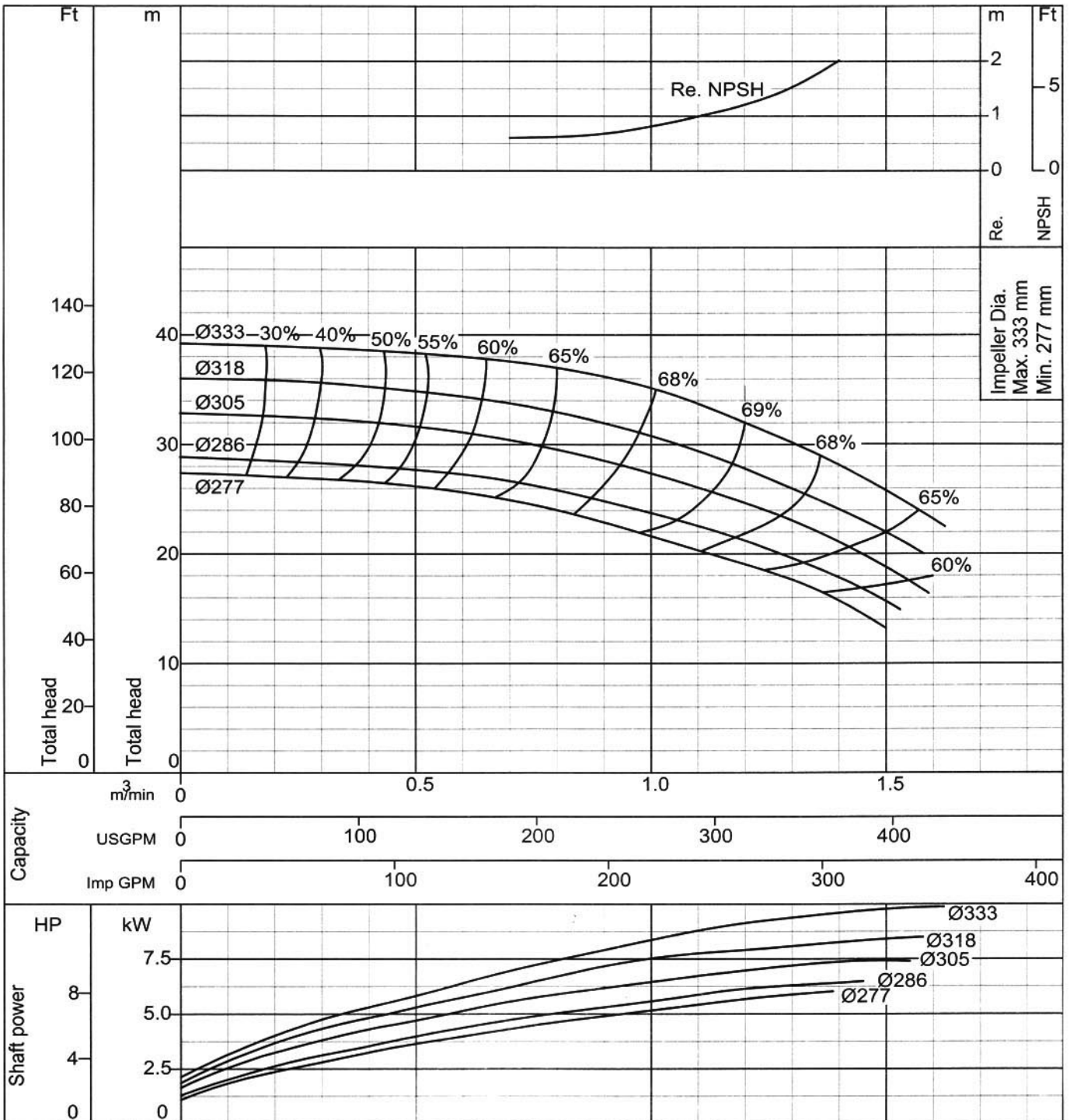

Curve No - 4 - 5FS5607R1

Ebara End Suction Volute Pump

Model FSA

Performance Curve 4 Poles (8/27)

50 Hz

100X80 FS4GA	According to ISO testing code 2548 Class C
50Hz (Approx. speed 1450min ⁻¹)	S.G.= 1.0 Vis.= 1.0 cSt

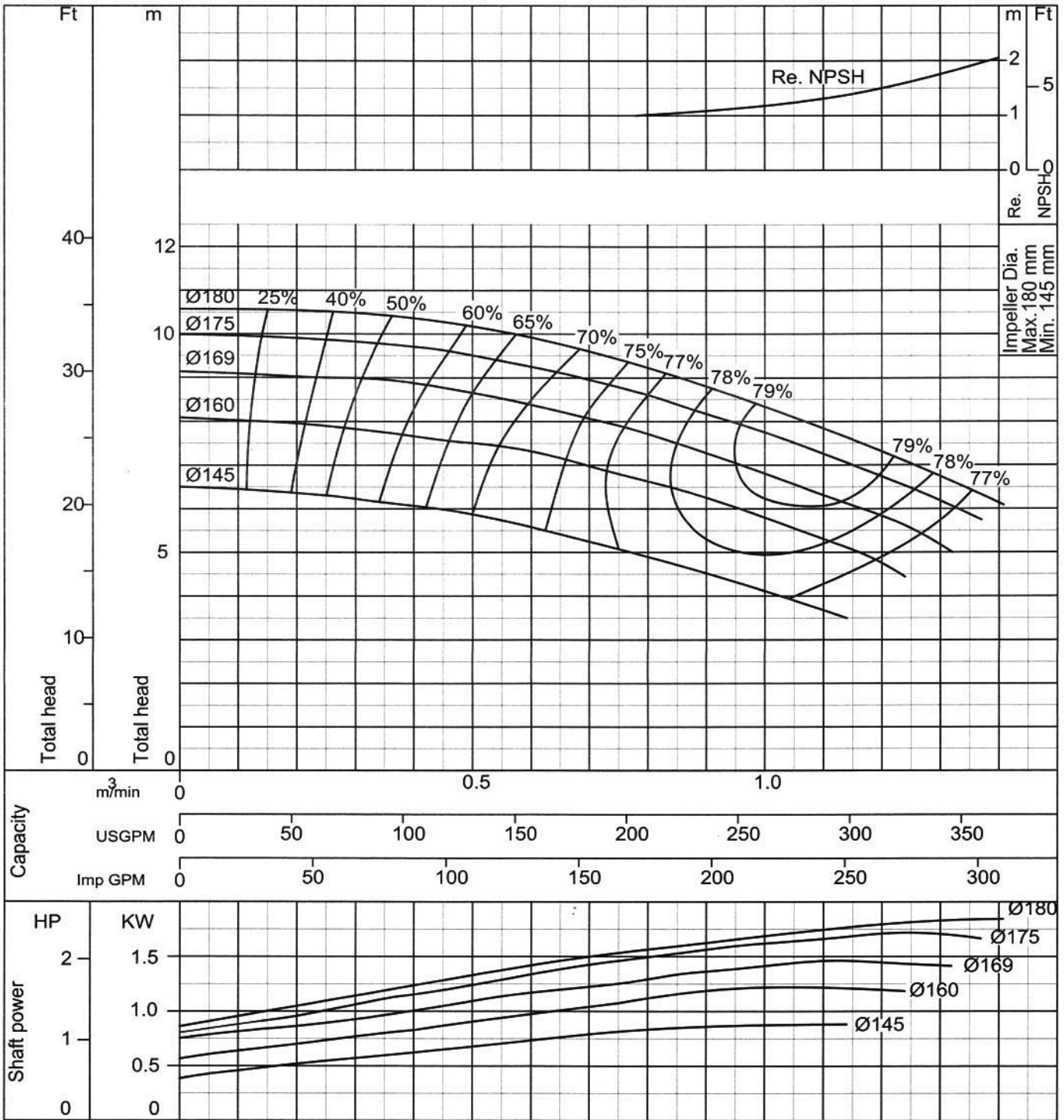

Curve No - 4 - 5FS5608R1

Ebara End Suction Volute Pump

Model FSA

Performance Curve 4 Poles (9/27)

50 Hz

100X80 FS4HA	According to ISO testing code 2548 Class C
50Hz (Approx. speed 1450min ⁻¹)	S.G.= 1.0 Vis.= 1.0 cSt

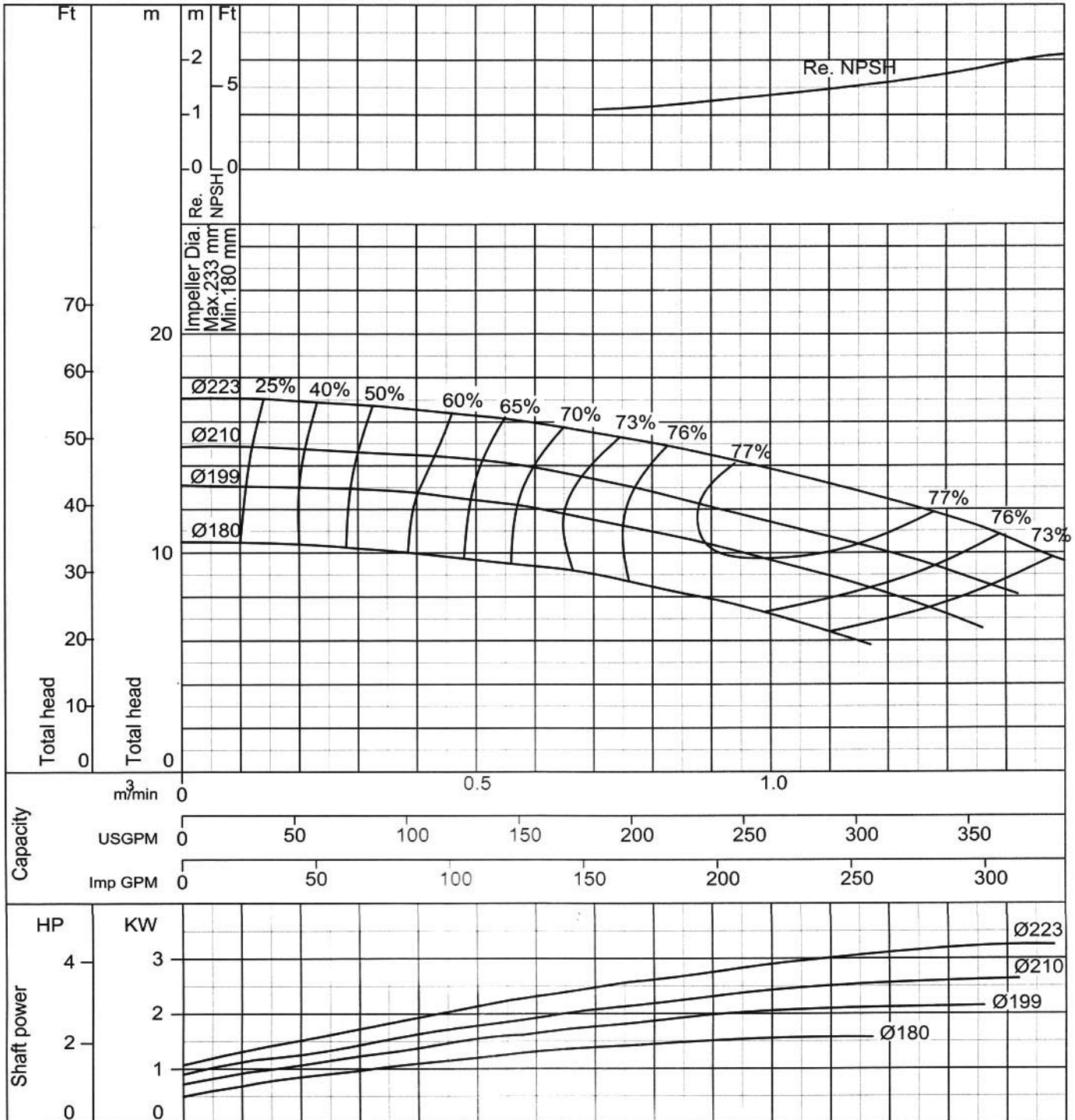

Curve No - 4 - 5FS5609R1

Ebara End Suction Volute Pump

Model FSA

Performance Curve 4 Poles (10/27)

50 Hz

100X80 FS4JA	According to ISO testing code 2548 Class C
50Hz (Approx. speed 1450min ⁻¹)	S.G.= 1.0 Vis.= 1.0 cSt

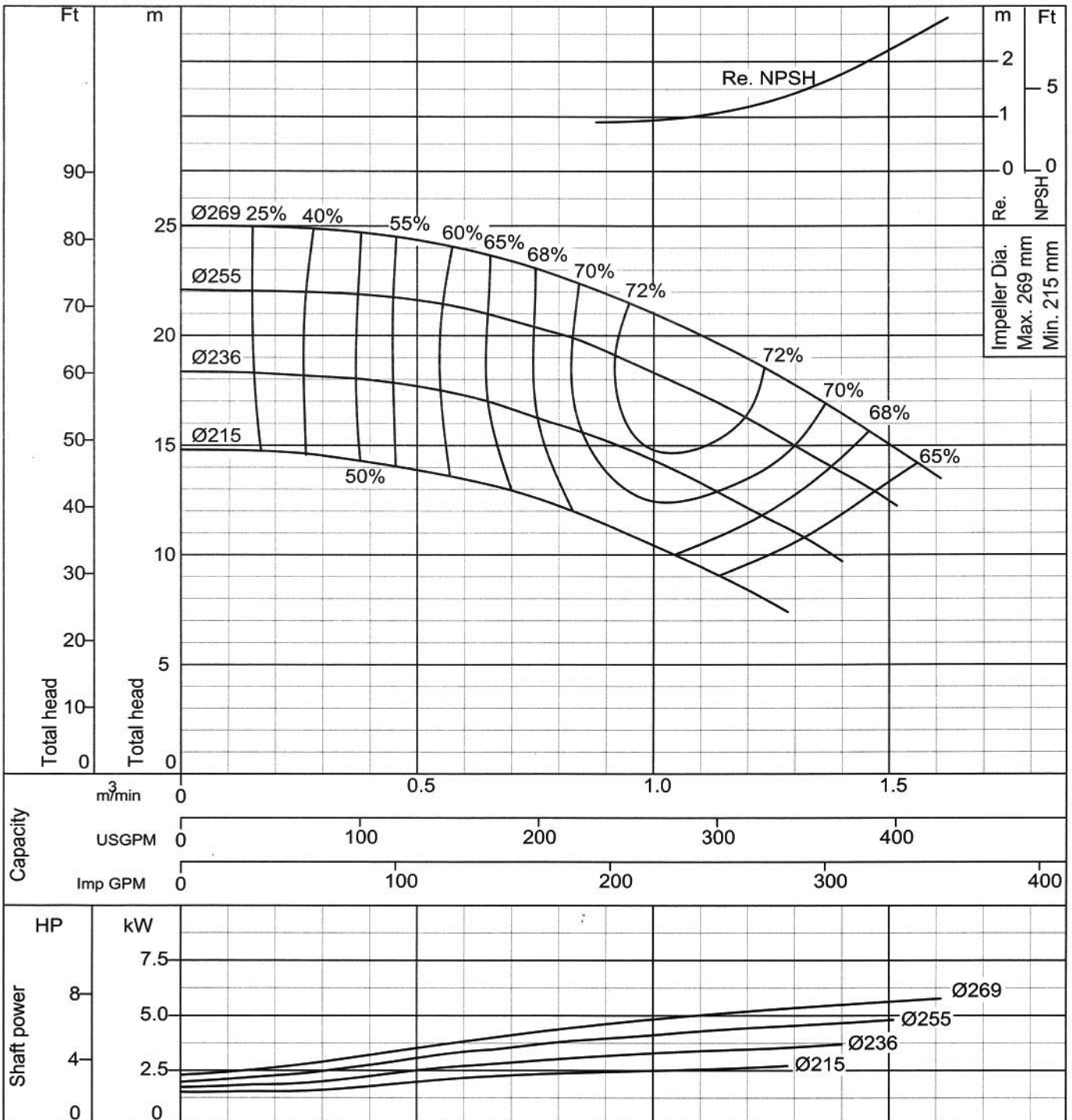

Curve No - 4 - 5FS5610R1

Ebara End Suction Volute Pump

Model FSA

Performance Curve 4 Poles (11/27)

50 Hz

100 x 80 FS4GCA	According to ISO testing code 2548 Class C
50Hz (Approx. speed 1450 min ⁻¹)	S.G.= 1.0 Vis.= 1.0 cSt

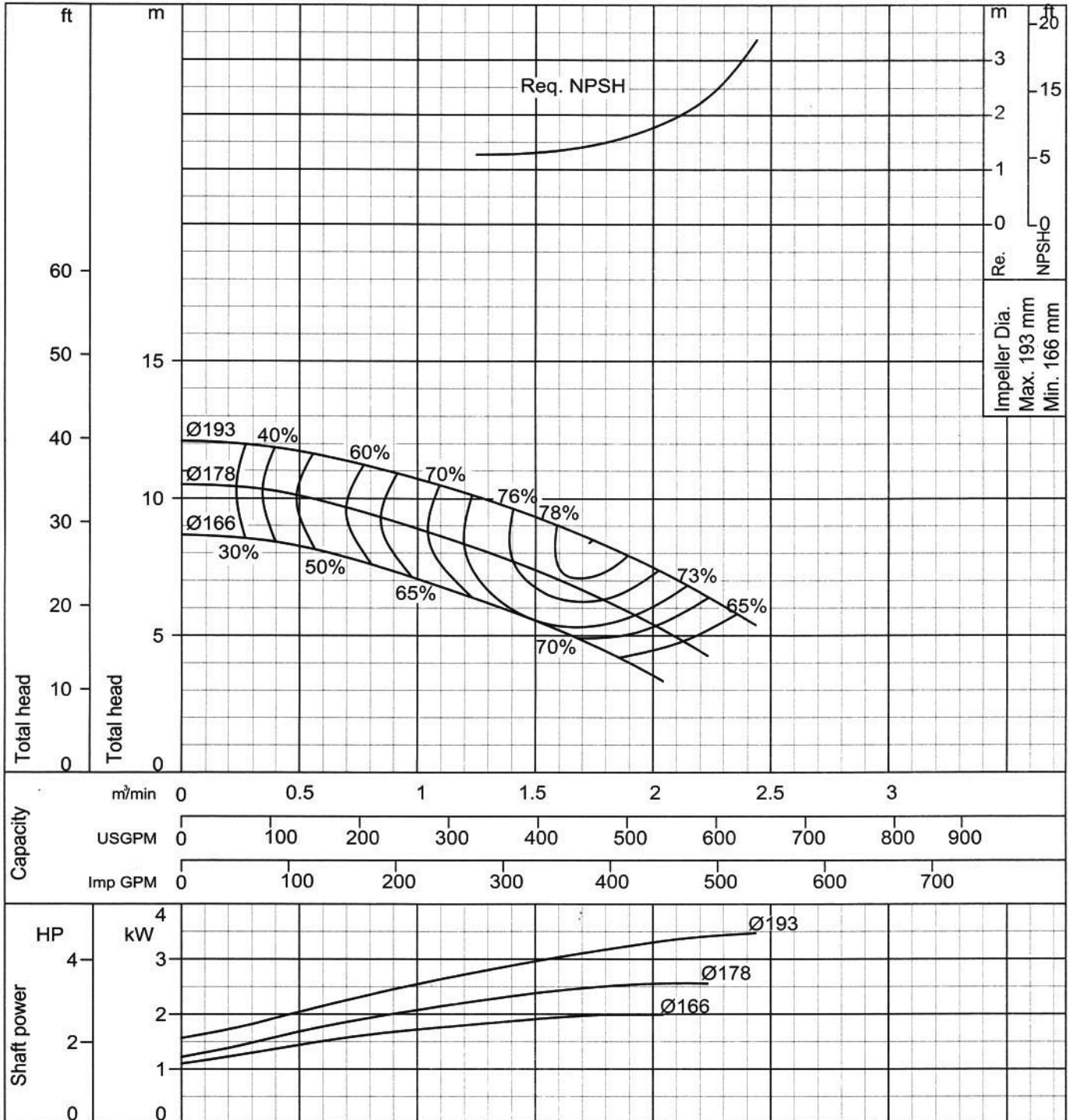

Curve No - 4 - 5FS5620R1

Ebara End Suction Volute Pump

Model FSA

Performance Curve 4 Poles (12/27)

50 Hz

100 x 80 FS4HCA	According to ISO testing code 2548 Class C
50Hz (Approx. speed 1450 min ⁻¹)	S.G.= 1.0 Vis.= 1.0 cSt

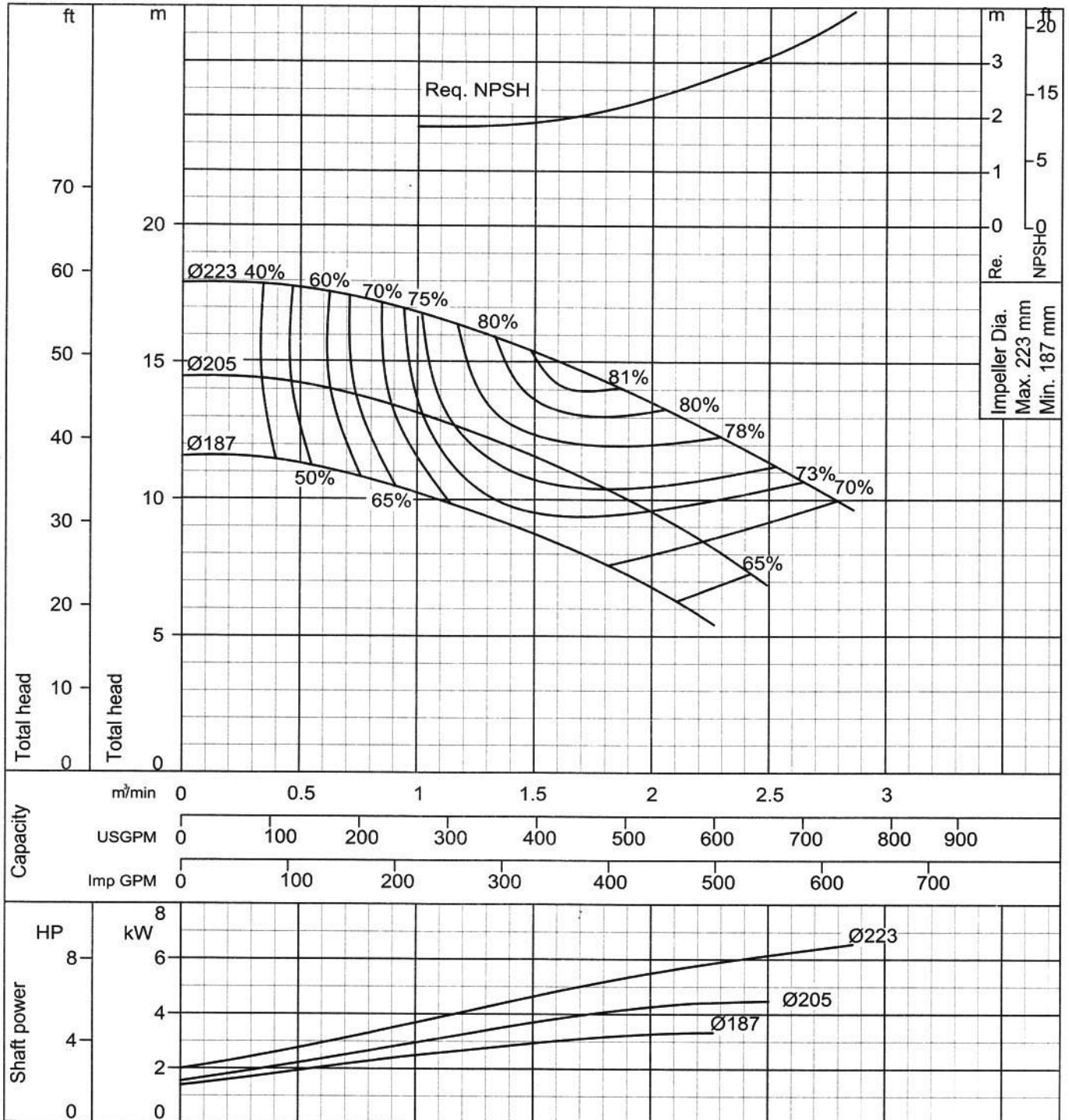

Curve No - 4 - 5FS5621R1

Ebara End Suction Volute Pump

Model FSA

Performance Curve 4 Poles (13/27)

50 Hz

125 x 100 FS4JCA

According to ISO testing code 2548 Class C

50Hz (Approx. speed 1450 min⁻¹)

S.G.= 1.0 Vis.= 1.0 cSt

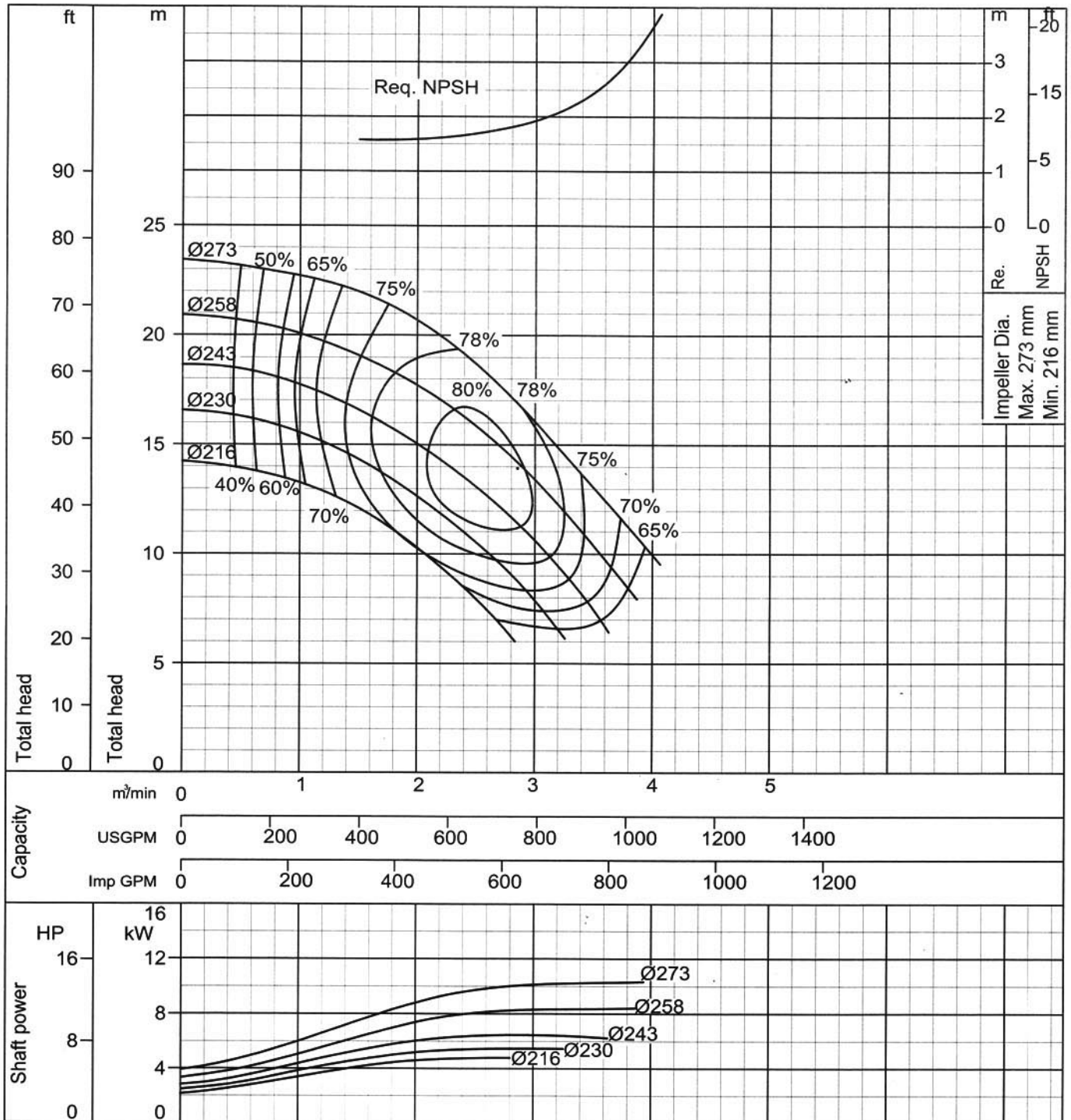

Curve No - 4 - 5FS5622R1

Ebara End Suction Volute Pump

Model FSA

Performance Curve 4 Poles (14/27)

50 Hz

125X100 FS4KA	According to ISO testing code 2548 Class C
50Hz (Approx. speed 1450min ⁻¹)	S.G.= 1.0 Vis.= 1.0 cSt

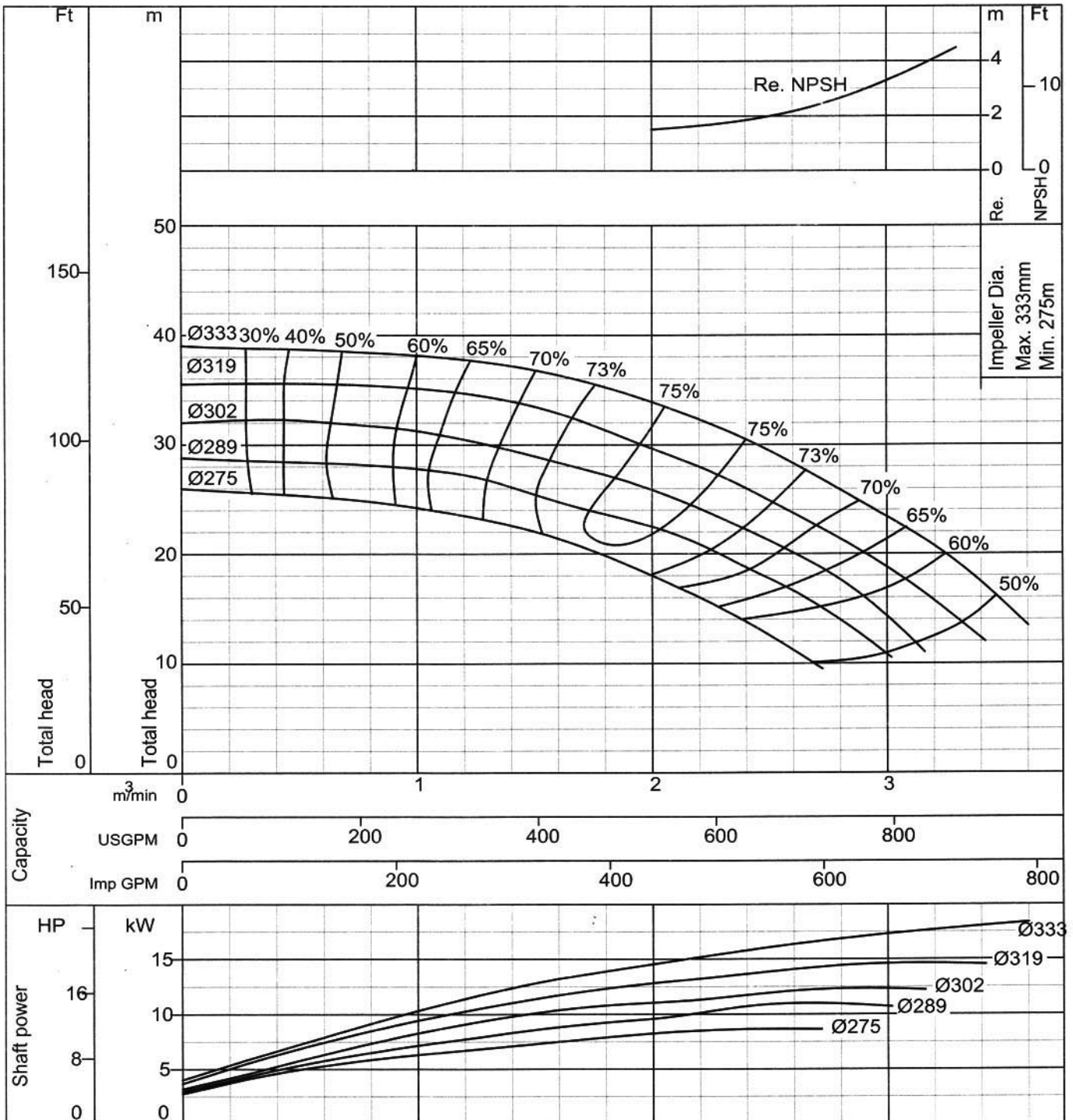

Curve No - 4 - 5FS5611R1

Ebara End Suction Volute Pump

Model FSA

Performance Curve 4 Poles (15/27)

50 Hz

125X100 FS4LA

According to ISO testing code 2548 Class C

50Hz (Approx. speed 1450min⁻¹)

S.G.= 1.0 Vis.= 1.0 cSt

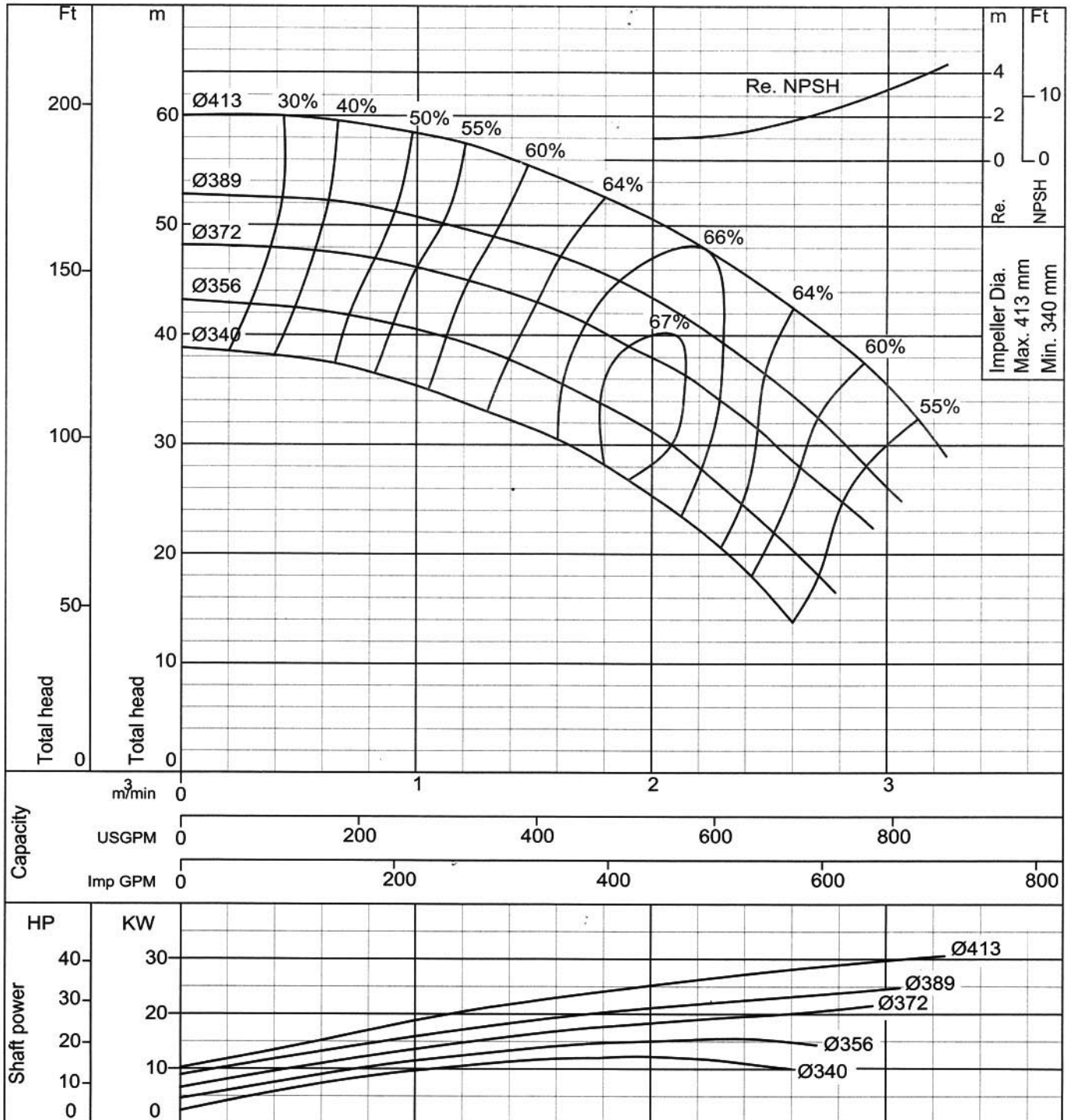

Curve No - 4 - 5FS5612R1

Ebara End Suction Volute Pump

Model FSA

Performance Curve 4 Poles (16/27)

50 Hz

150X125 FS4HA	According to ISO testing code 2548 Class C
50Hz (Approx. speed 1450min ⁻¹)	S.G.= 1.0 Vis.= 1.0 cSt

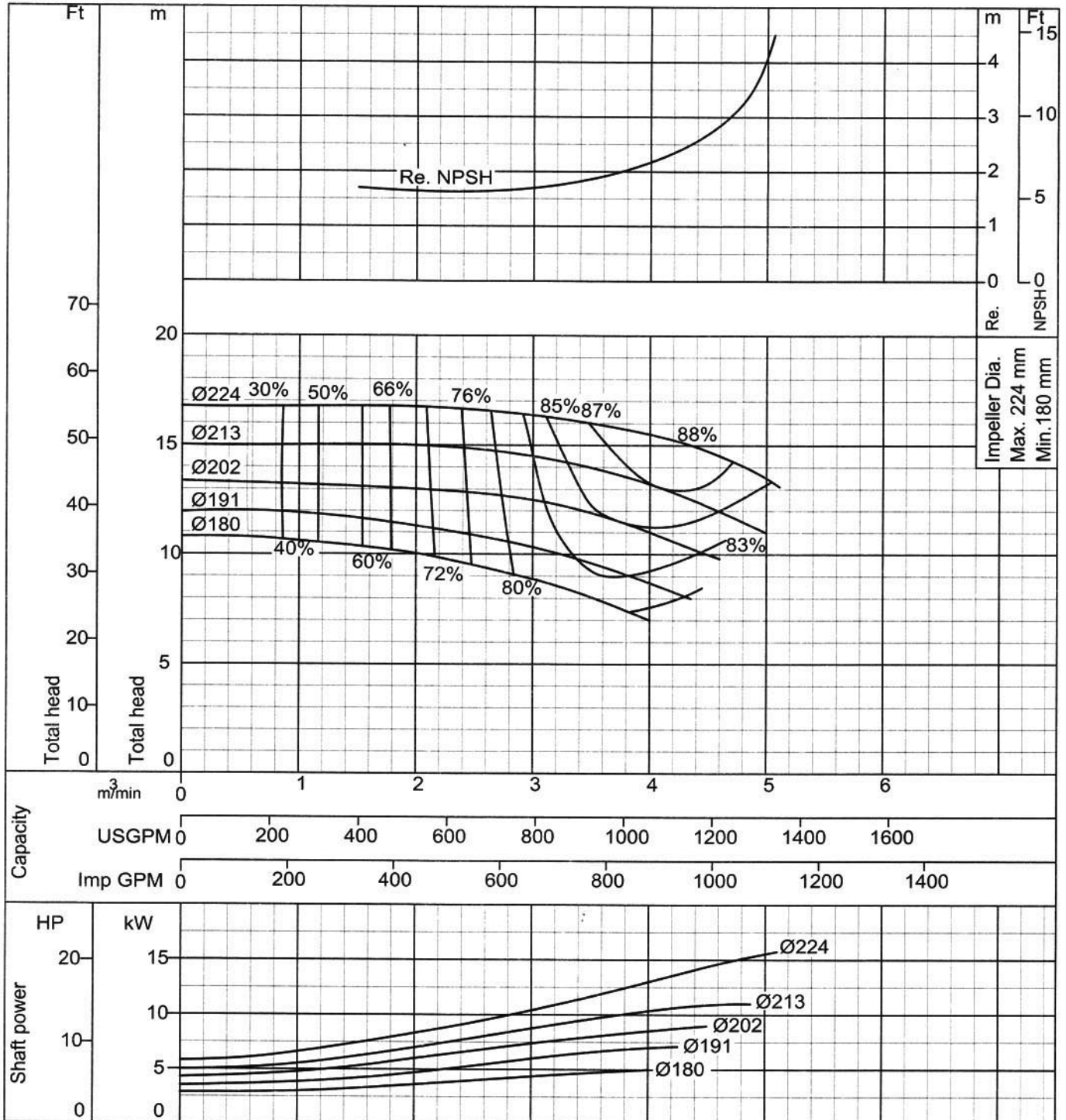

Curve No - 4 - 5FS5613R1

Ebara End Suction Volute Pump

Model FSA

Performance Curve 4 Poles (17/27)

50 Hz

150X125 FS4JA

According to ISO testing code 2548 Class C

50Hz (Approx. speed 1450min⁻¹)

S.G.= 1.0 Vis.= 1.0 cSt

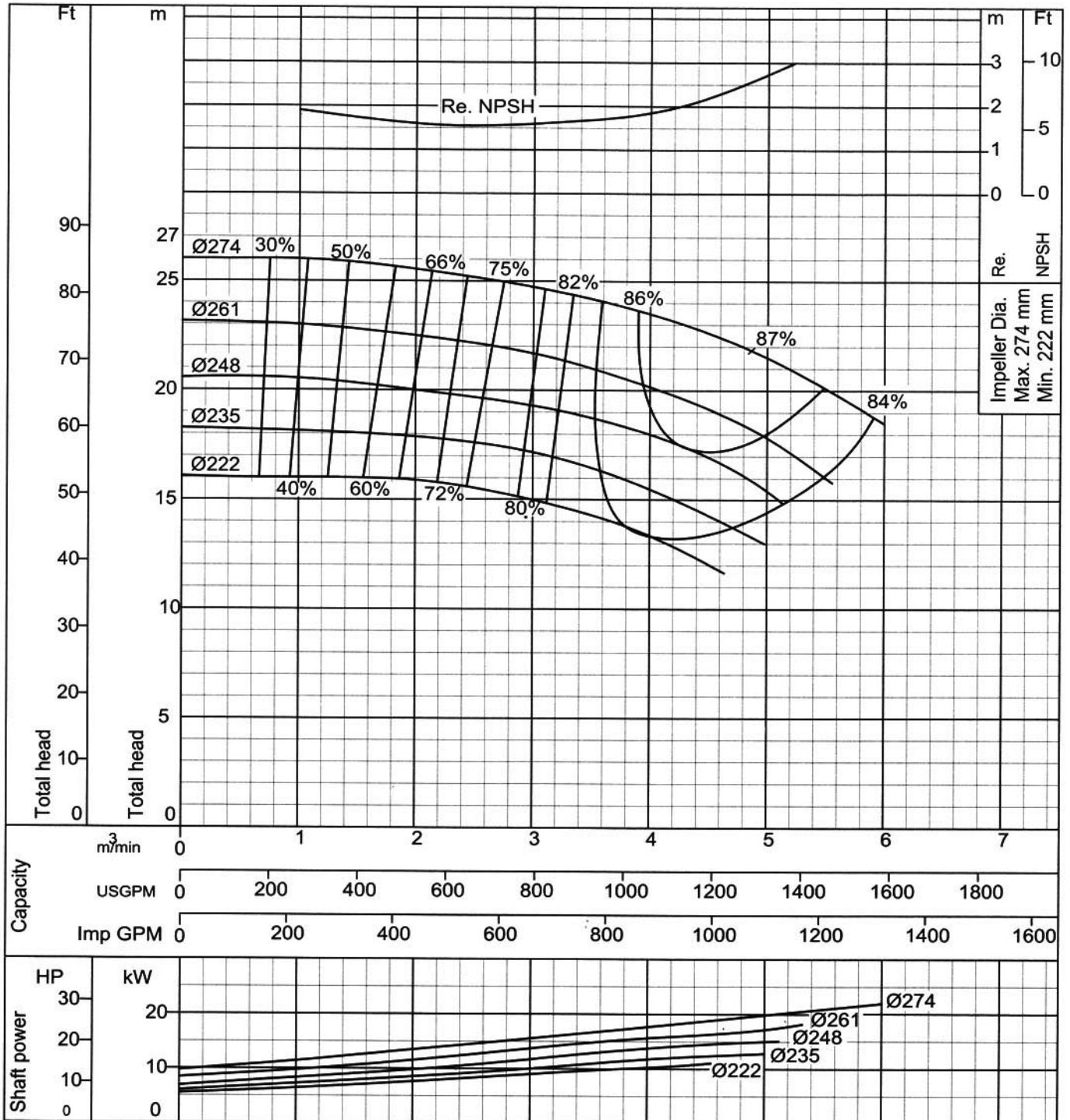

Curve No - 4 - 5FS5614R1

Ebara End Suction Volute Pump

Model FSA

Performance Curve 4 Poles (18/27)

50 Hz

150X125 FS4KA

According to ISO testing code 2548 Class C

50Hz (Approx. speed 1450min⁻¹)

S.G.= 1.0 Vis.= 1.0 cSt

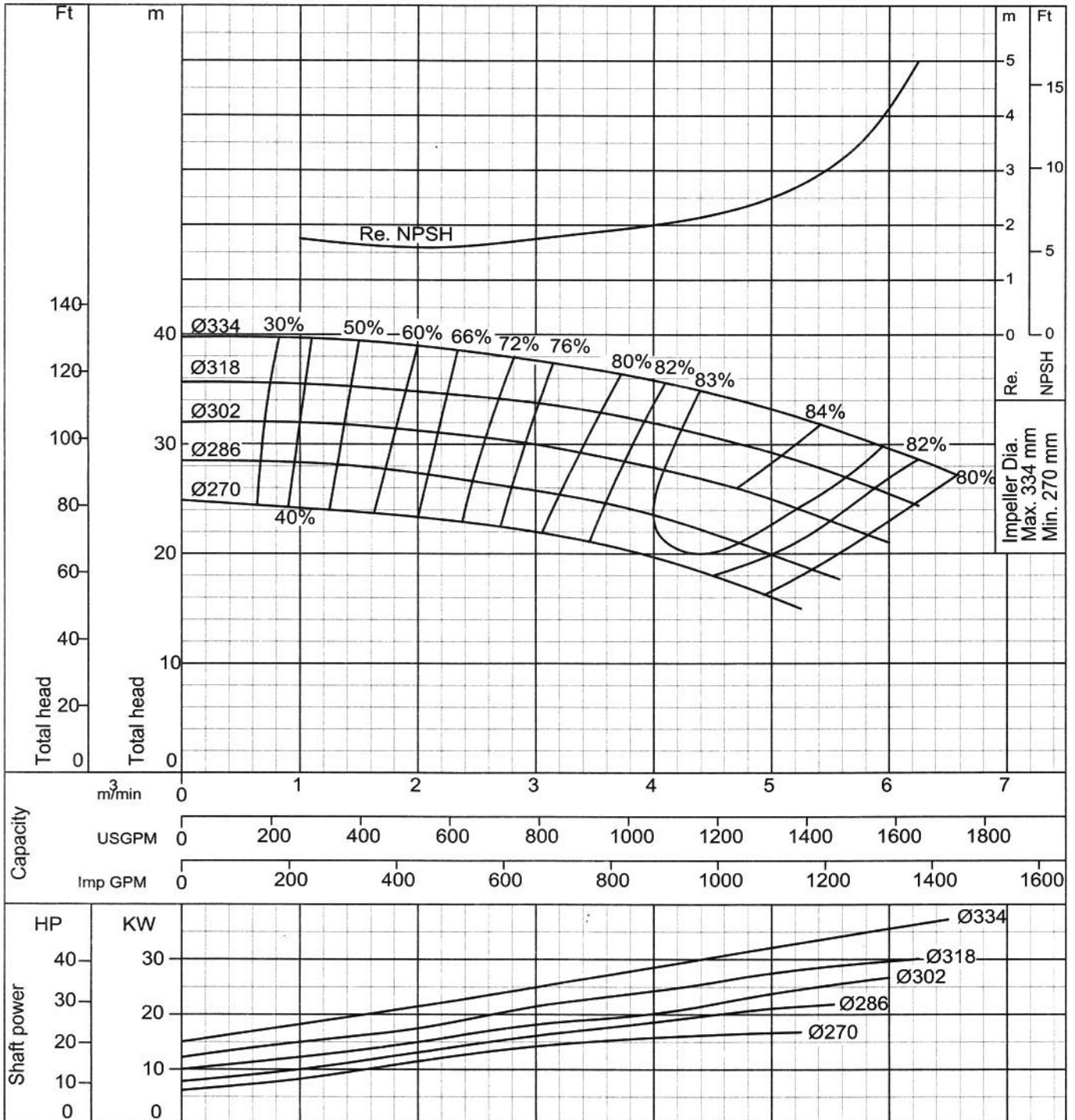

Curve No - 4 - 5FS5615R1

Ebara End Suction Volute Pump

Model FSA

Performance Curve 4 Poles (19/27)

50 Hz

150X125 FS4LA	According to ISO testing code 2548 Class C
50Hz (Approx. speed 1450min ⁻¹)	S.G.= 1.0 Vis.= 1.0 cSt

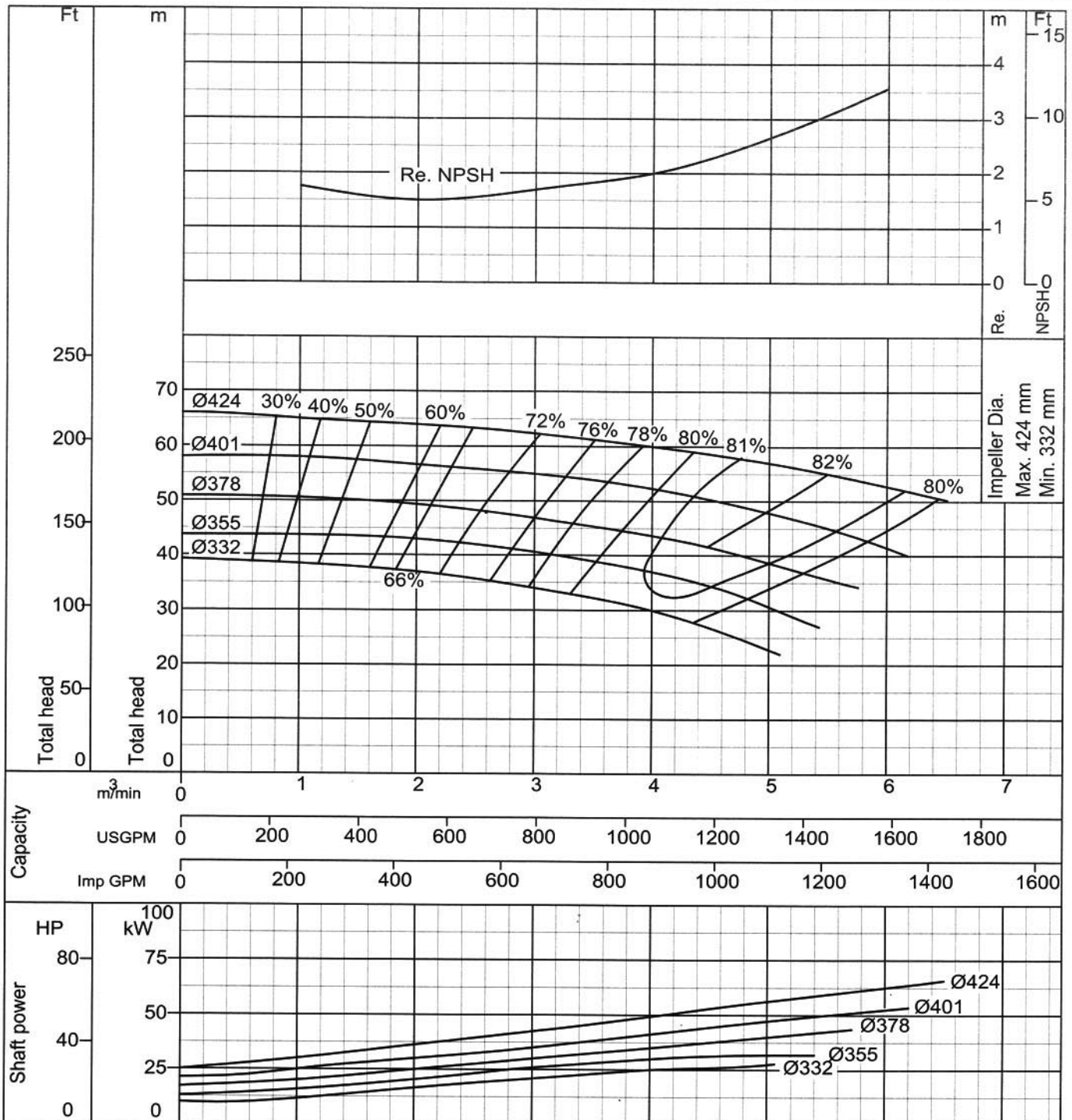

Curve No - 4 - 5FS5616R1

Ebara End Suction Volute Pump

Model FSA

Performance Curve 4 Poles (20/27)

50 Hz

150 x 100 FS4NA	According to ISO testing code 2548 Class C
50Hz (Approx. speed 1450 min ⁻¹) S.G.= 1.0 Vis.= 1.0 cSt	

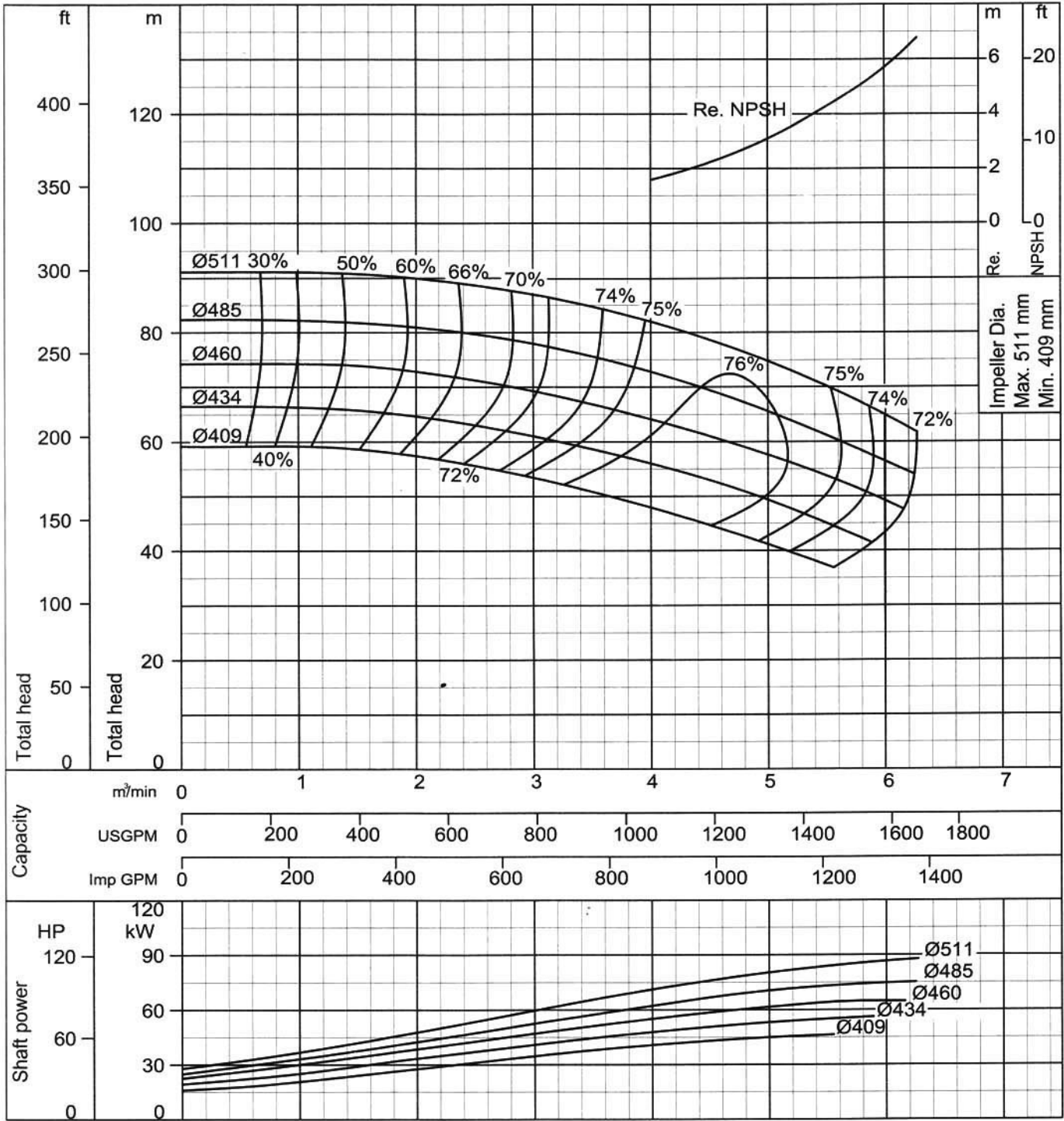

Curve No - 4 - 5FS5624R1

Ebara End Suction Volute Pump

Model FSA

Performance Curve 4 Poles (21/27)

50 Hz

200X150 FS4HA

According to ISO testing code 2548 Class C

50Hz (Approx. speed 1450min⁻¹)

S.G.= 1.0 Vis.= 1.0 cSt

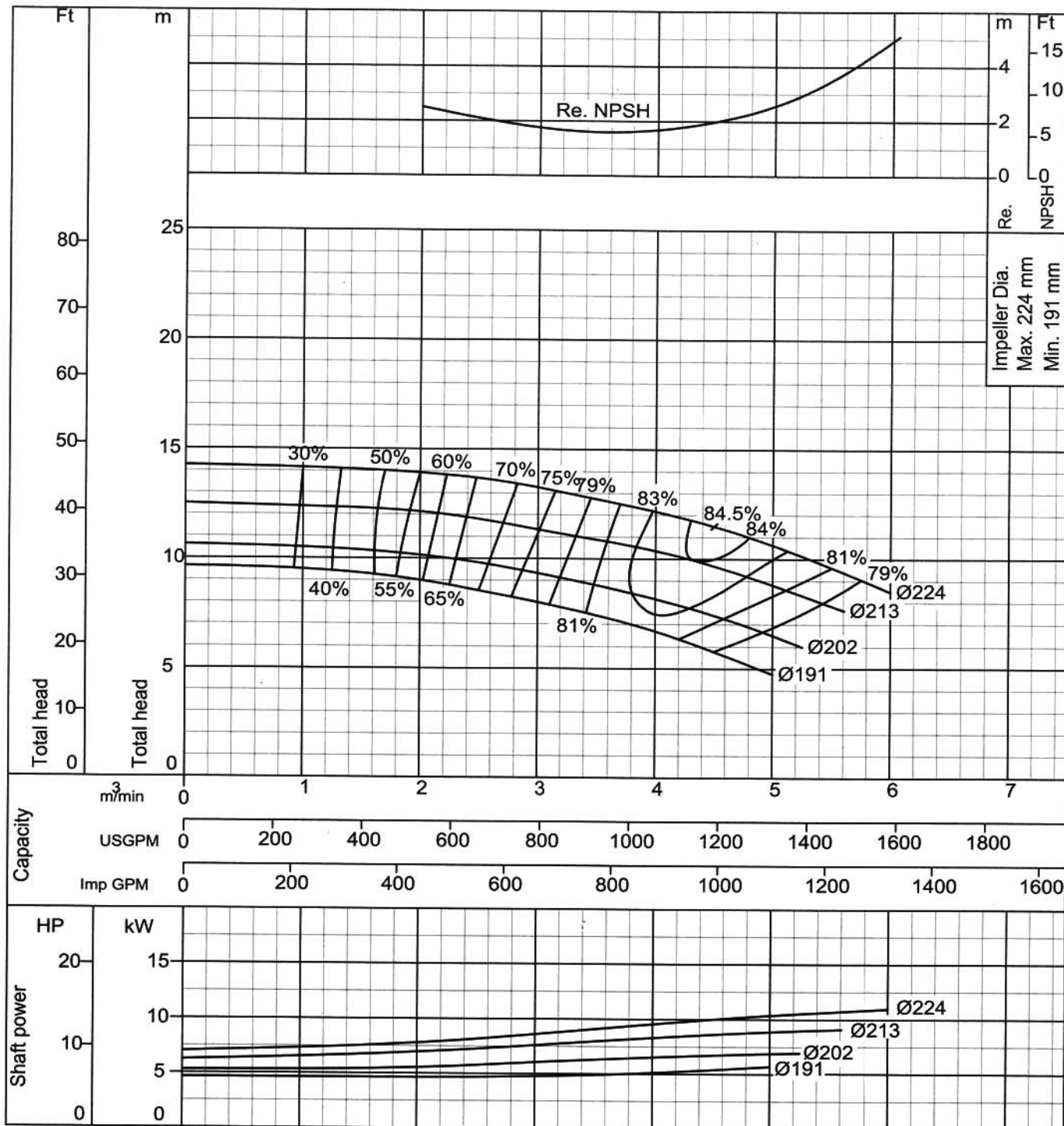

Curve No - 4 - 5FS5617R1

Ebara End Suction Volute Pump

Model FSA

Performance Curve 4 Poles (22/27)

50 Hz

200X150 FS4JA	According to ISO testing code 2548 Class C
50Hz (Approx. speed 1450min ⁻¹)	S.G.= 1.0 Vis.= 1.0 cSt

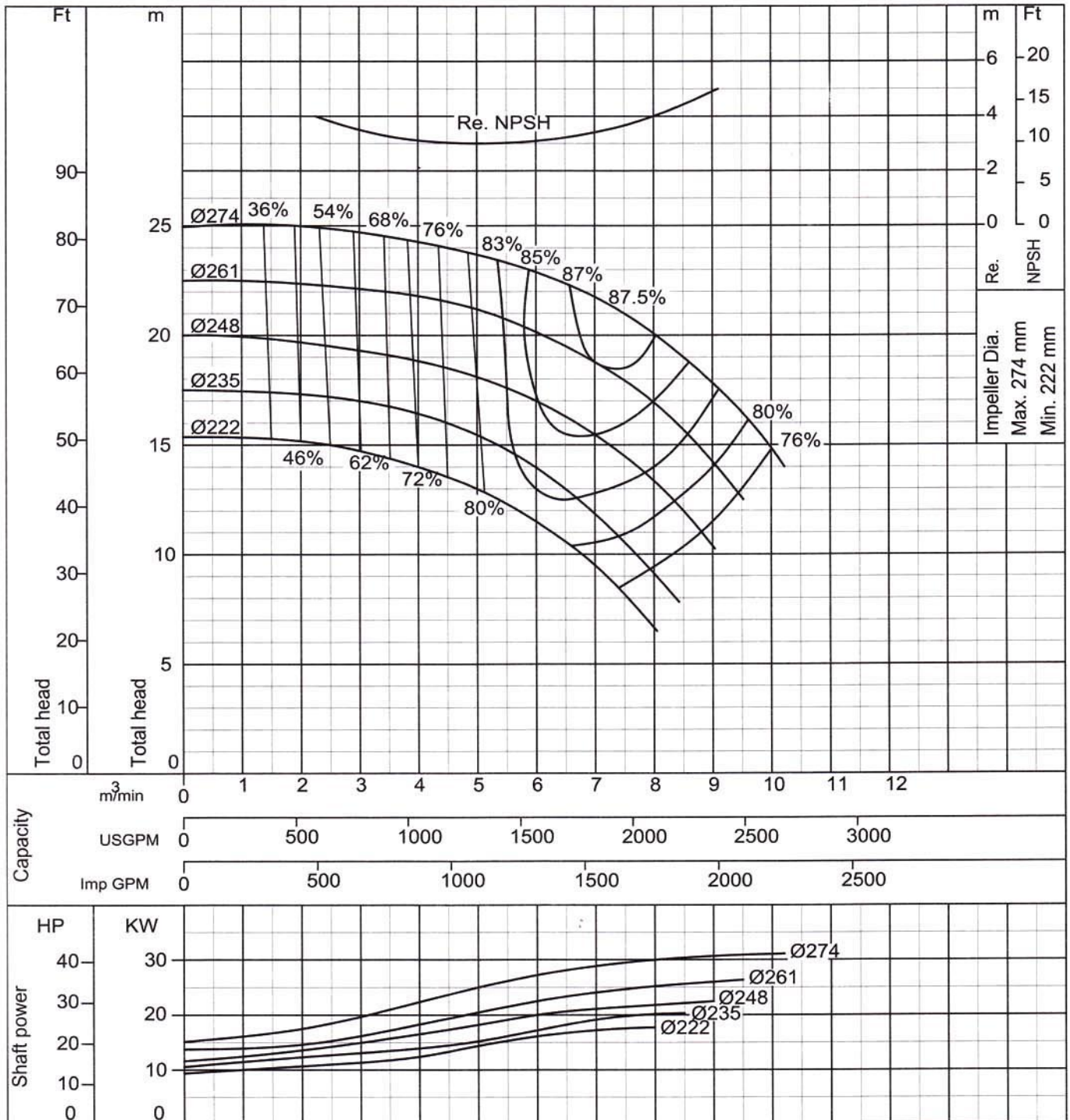

Curve No - 4 - 5FS5618R1

Ebara End Suction Volute Pump

Model FSA

Performance Curve 4 Poles (23/27)

50 Hz

200X150 FS4KA	According to ISO testing code 2548 Class C
50Hz (Approx. speed 1450min ⁻¹)	S.G.= 1.0 Vis.= 1.0 cSt

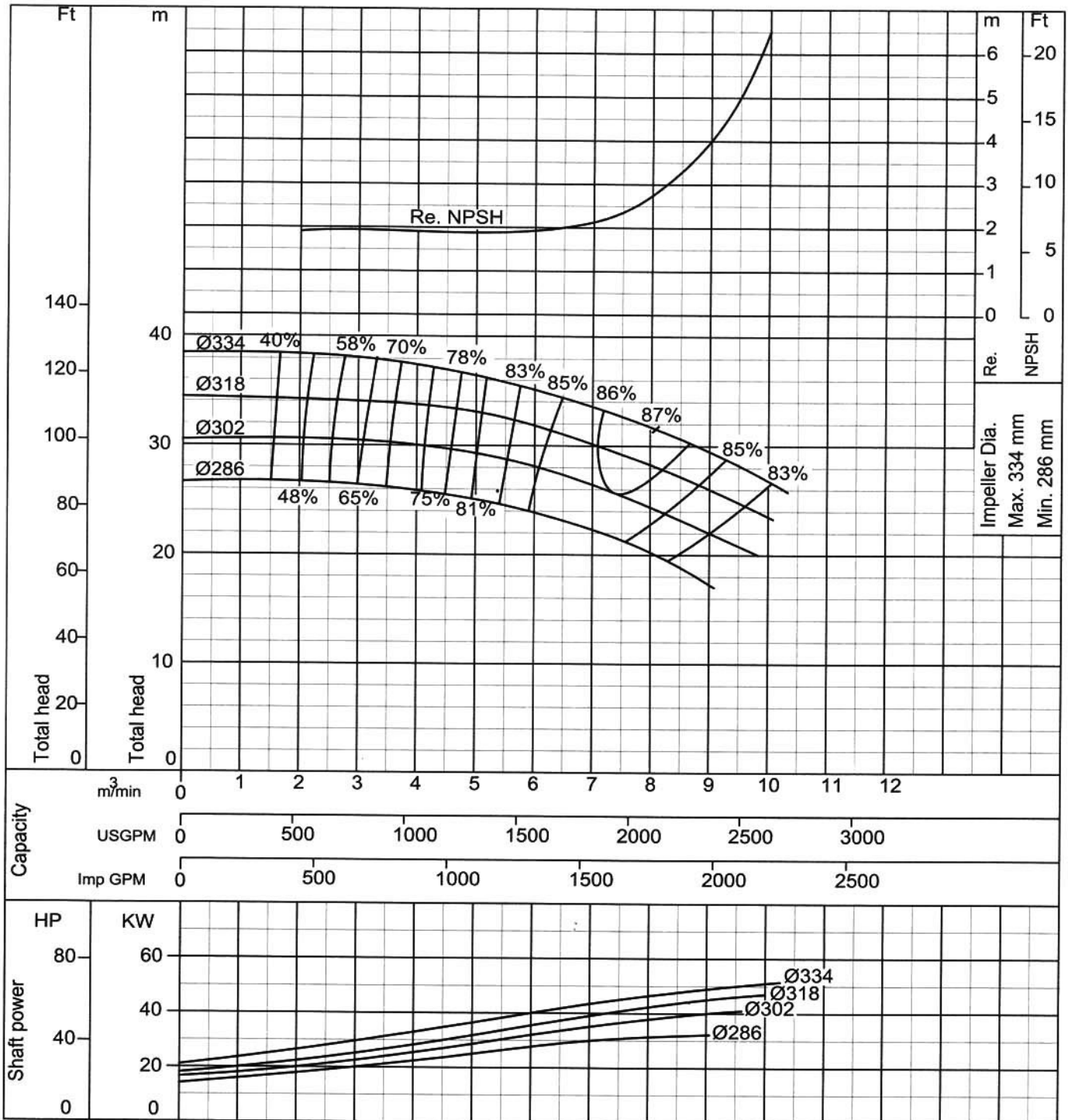

Curve No - 4 - 5FS5619R1

Ebara End Suction Volute Pump

Model FSA

Performance Curve 4 Poles (24/27)

50 Hz

250 x 200 FS4LA	According to ISO testing code 2548 Class C
50Hz (Approx. speed 1450 min ⁻¹)	S.G.= 1.0 Vis.= 1.0 cSt

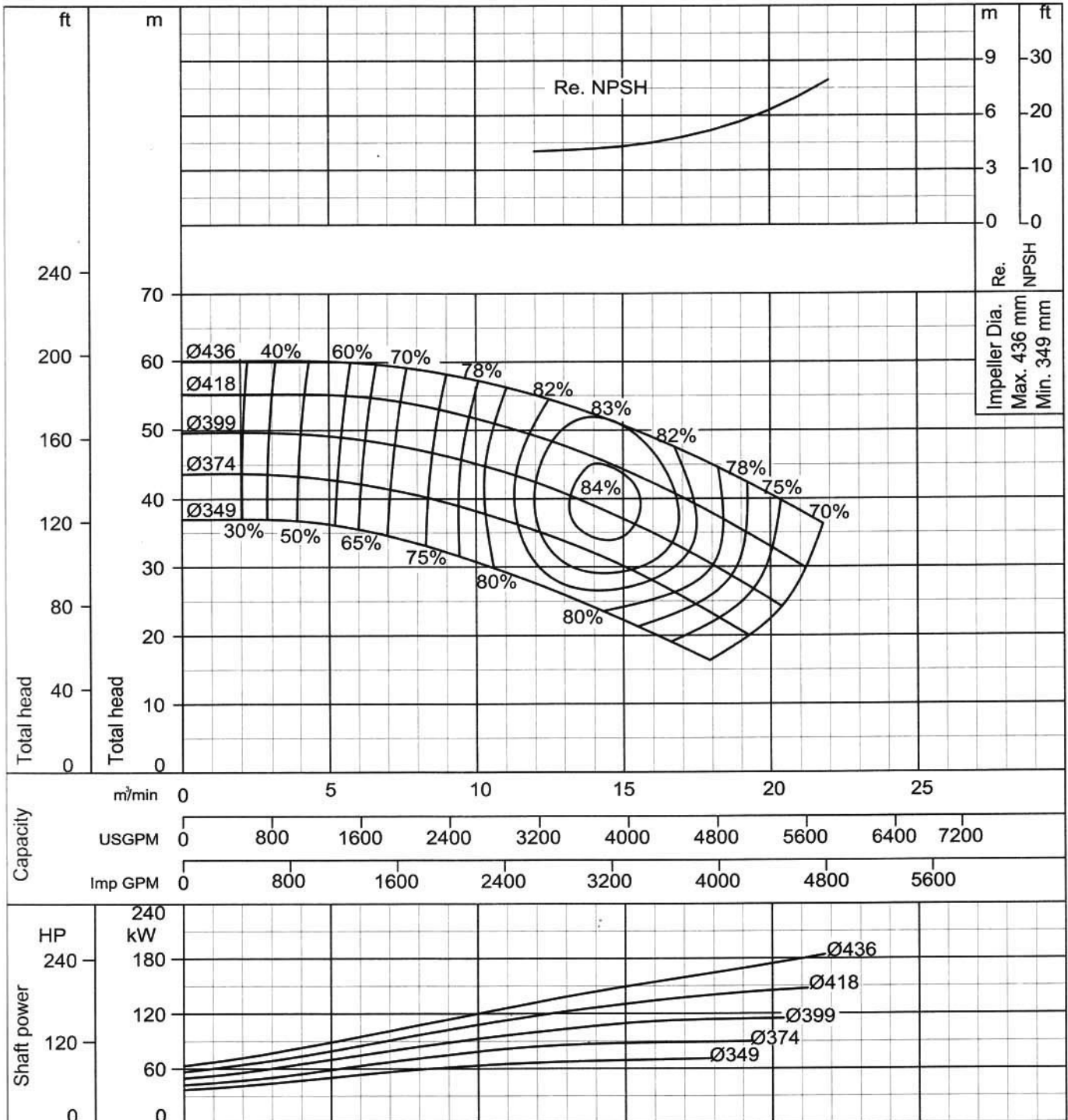

Curve No - 4 - 5FS5625R1

Ebara End Suction Volute Pump

Model FSA

Performance Curve 4 Poles (25/27)

50 Hz

200 x 150 FS4NA	According to ISO testing code 2548 Class C
50Hz (Approx. speed 1450 min ⁻¹)	S.G.= 1.0 Vis.= 1.0 cSt

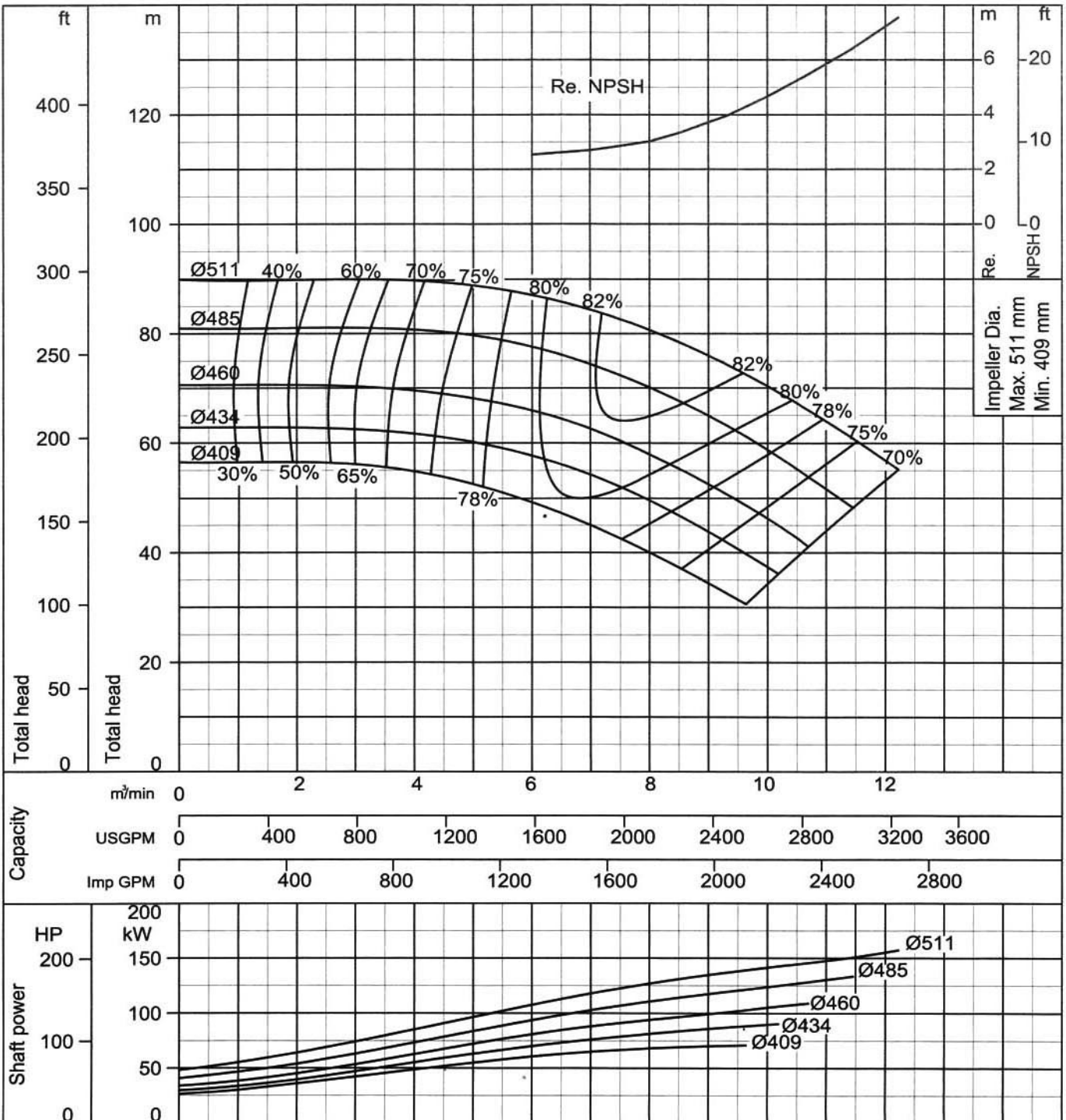

Curve No - 4 - 5FS5626R1

Ebara End Suction Volute Pump

Model FSA

Performance Curve 4 Poles (26/27)

50 Hz

250 x 200 FS4LA	According to ISO testing code 2548 Class C
50Hz (Approx. speed 1450 min ⁻¹)	S.G.= 1.0 Vis.= 1.0 cSt

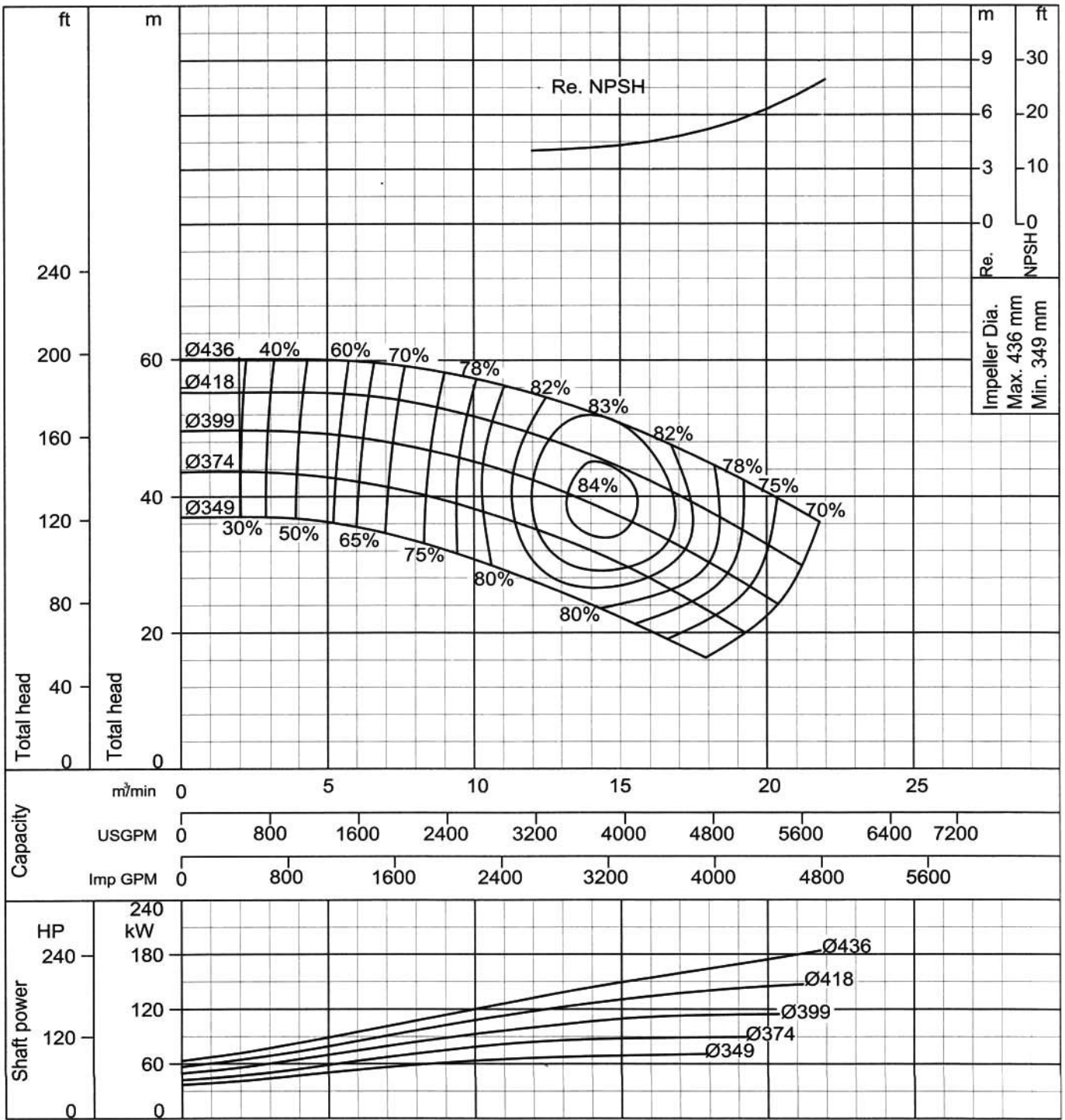

Curve No - 4 - 5FS5627R1

Ebara End Suction Volute Pump

Model FSA

Performance Curve 4 Poles (27/27)

50 Hz

250 x 200 FS4NA	According to ISO testing code 2548 Class C
50Hz (Approx. speed 1450 min ⁻¹)	S.G.= 1.0 Vis.= 1.0 cSt

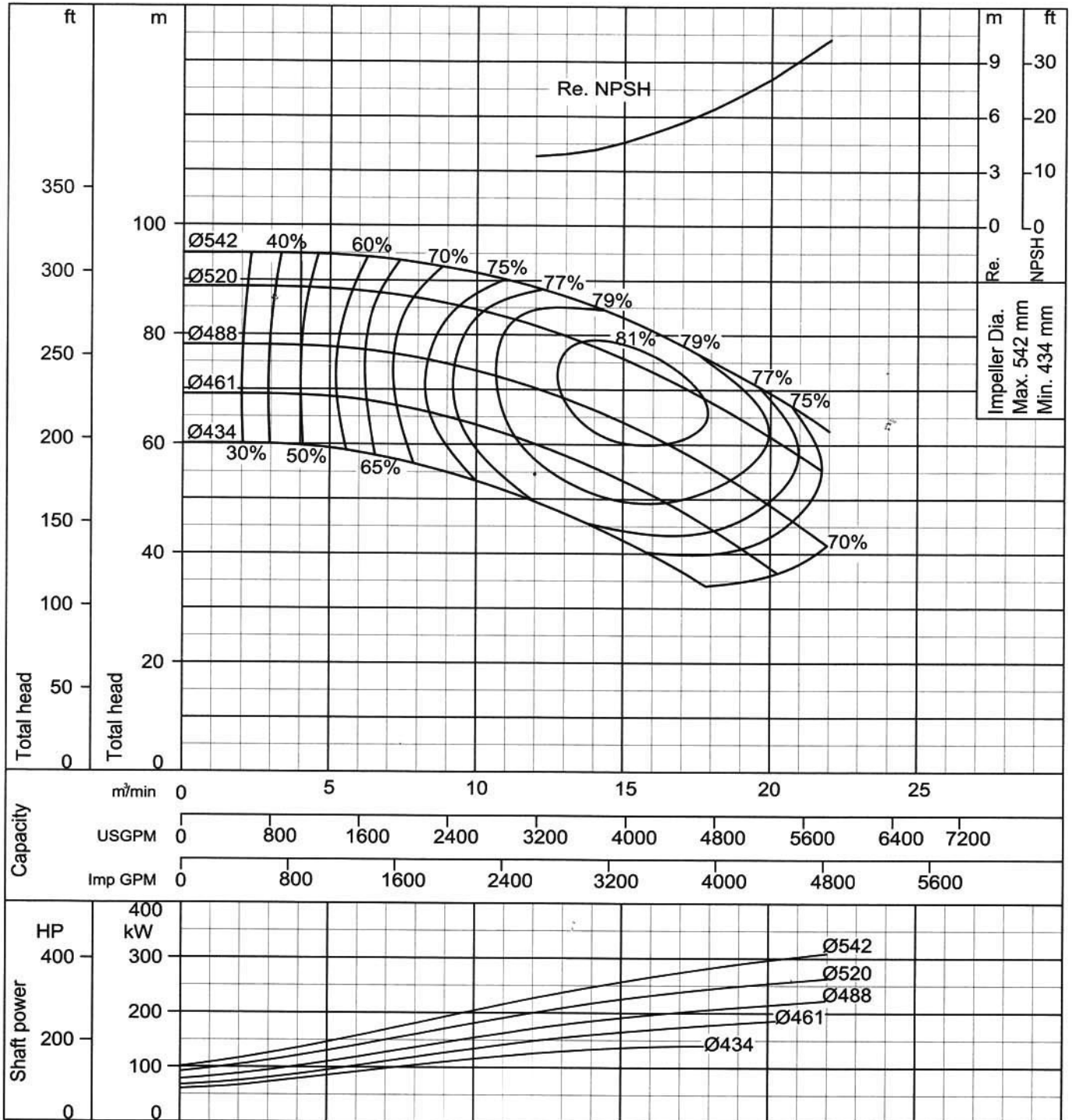

Curve No - 4 - 5FS5628R1

Ebara End Suction Volute Pump

Model FSA

Performance Curve 2 Poles (1/14)

50 Hz

50 x 40 FS2HA	According to ISO testing code 2548 Class C
50Hz (Approx. speed 2900 min ⁻¹)	S.G.= 1.0 Vis.= 1.0 cSt

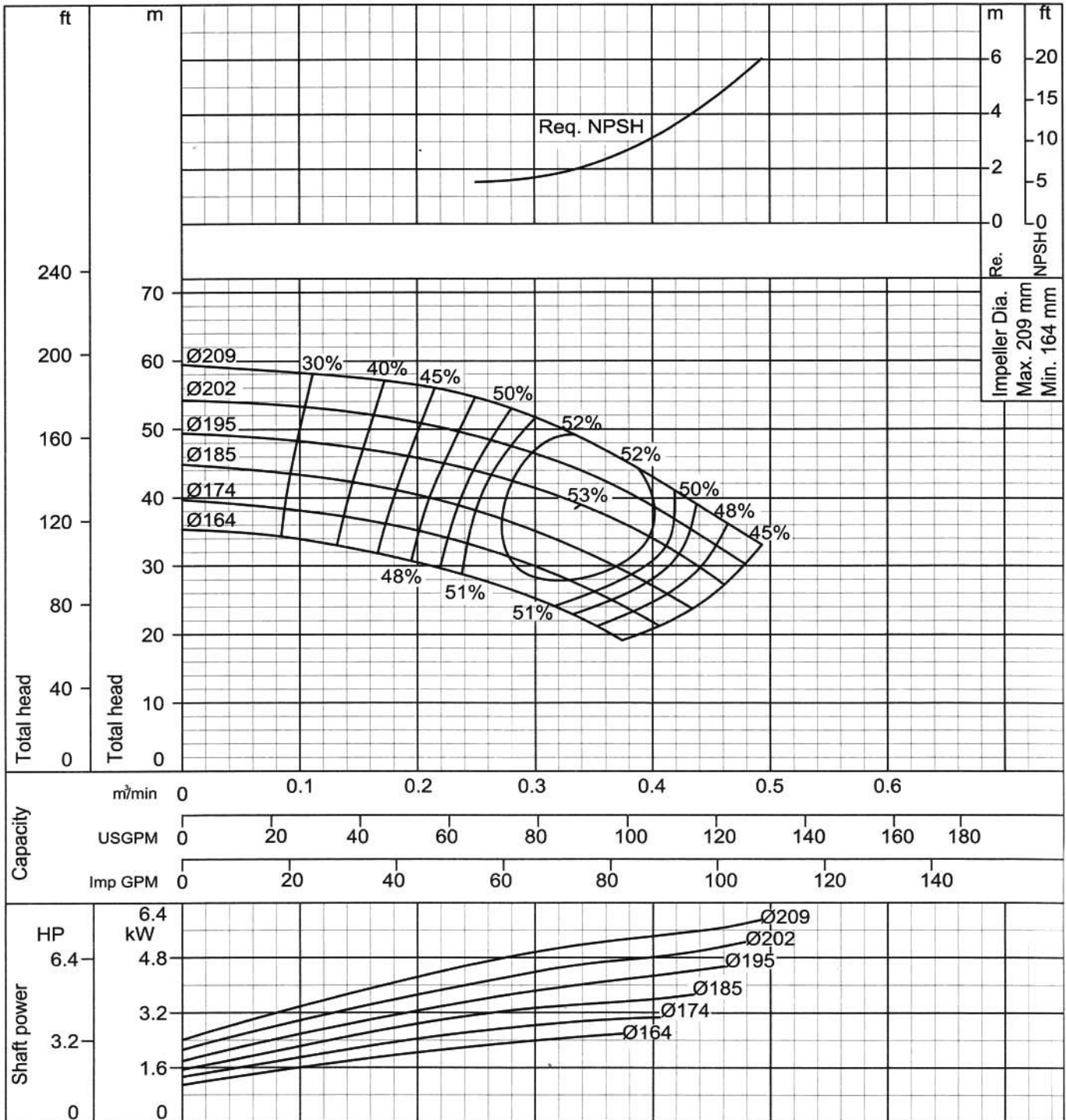

Curve No - 2 - 5FS5601R1

Ebara End Suction Volute Pump

Model FSA

Performance Curve 2 Poles (2/14)

50 Hz

65X50 FS2HA	According to ISO testing code 2548 Class C
	50Hz (Approx. speed 2900min ⁻¹) S.G.= 1.0 Vis.= 1.0 cSt

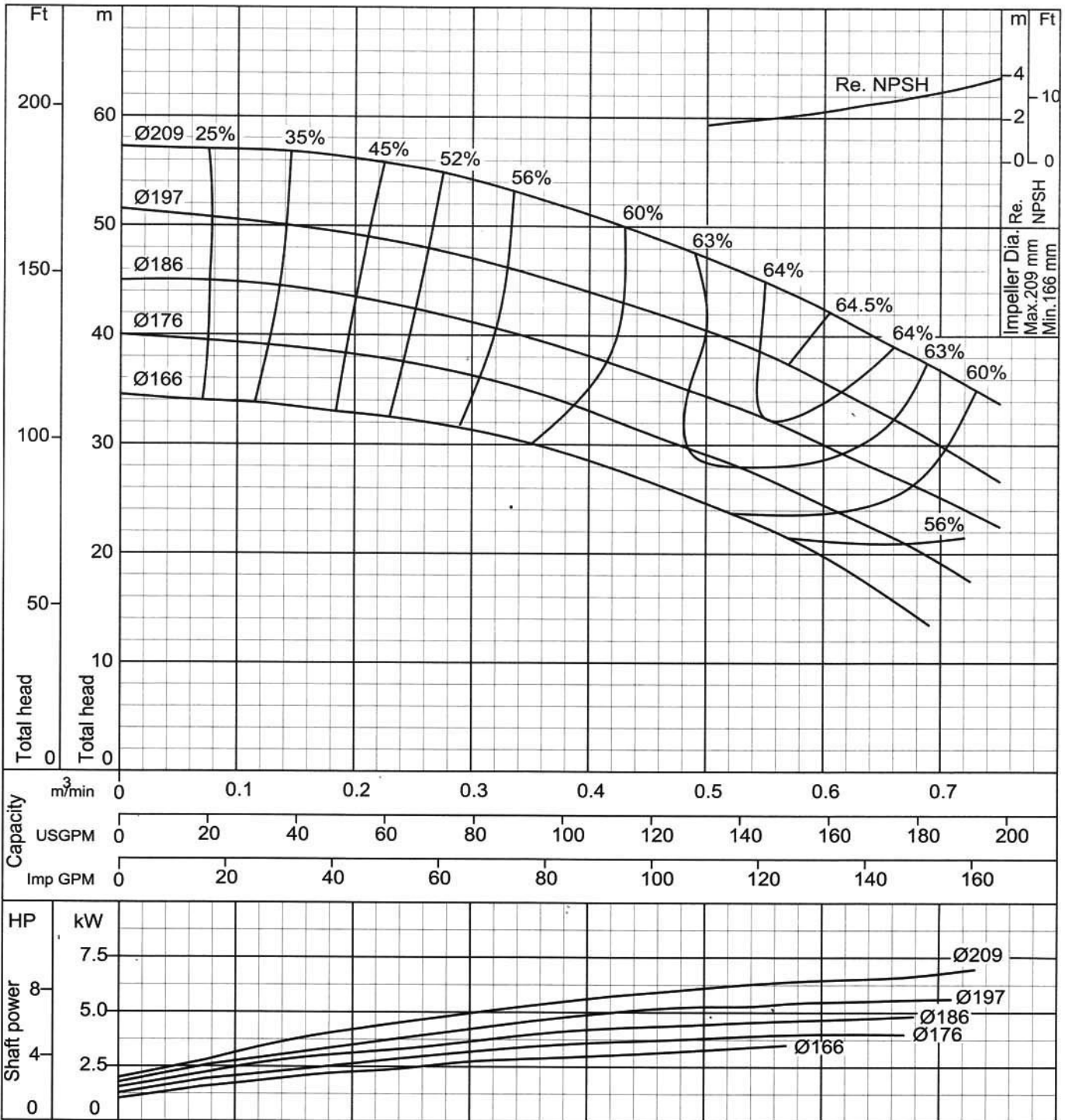

Curve No - 2 - 5FS5602R1

Ebara End Suction Volute Pump

Model FSA

Performance Curve 2 Poles (3/14)

50 Hz

65X50FS2J

According to ISO testing code 2548 Class C

50Hz (Approx. speed 2900min⁻¹)

S.G.= 1.0 Vis.= 1.0 cSt

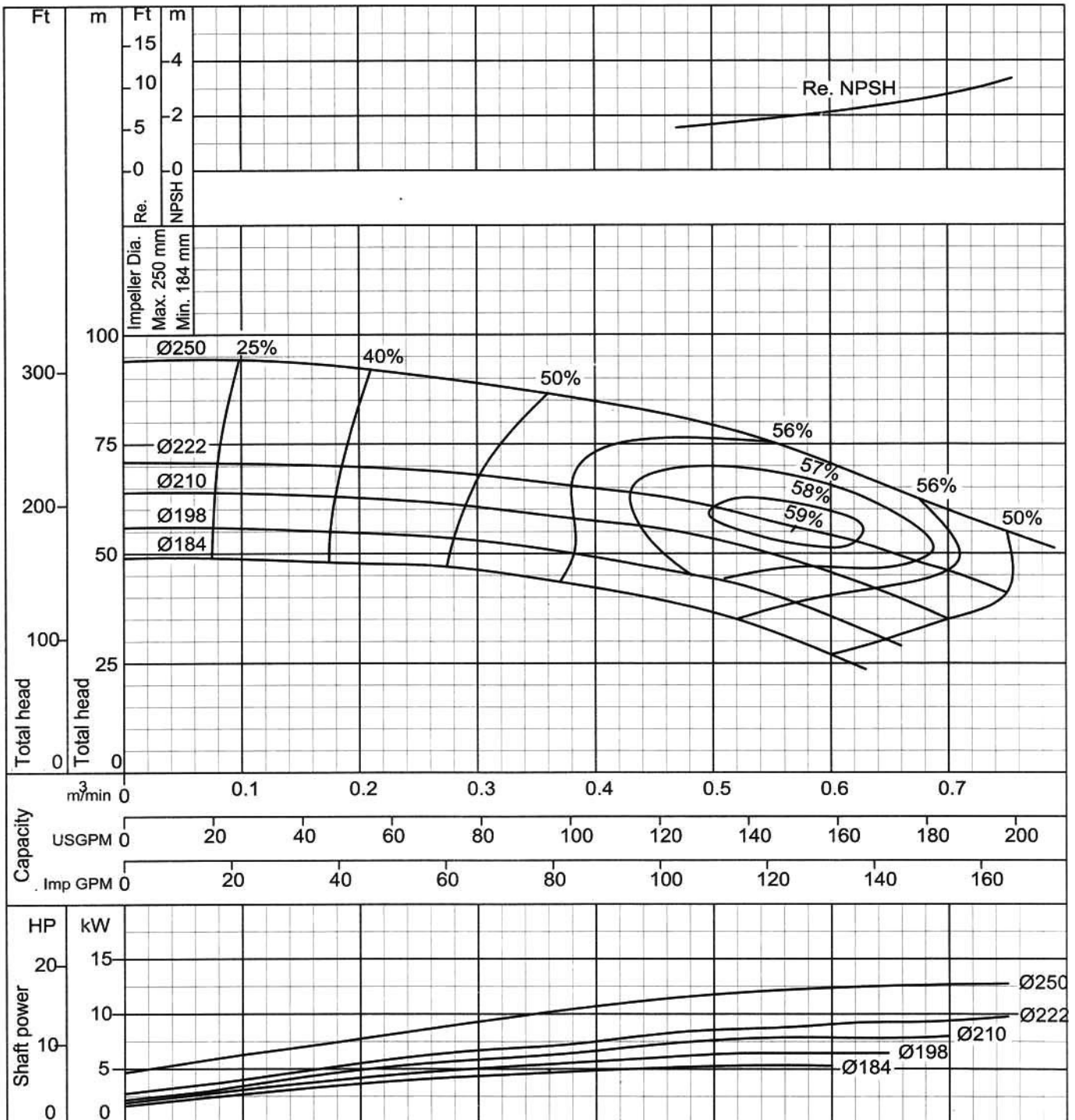

Curve No - 2 - 5FS5603R1

Ebara End Suction Volute Pump

Model FSA

Performance Curve 2 Poles (4/14)

50 Hz

80X65 FS2GA

According to ISO testing code 2548 Class C

50Hz (Approx. speed 2900min⁻¹)

S.G.= 1.0 Vis.= 1.0 cSt

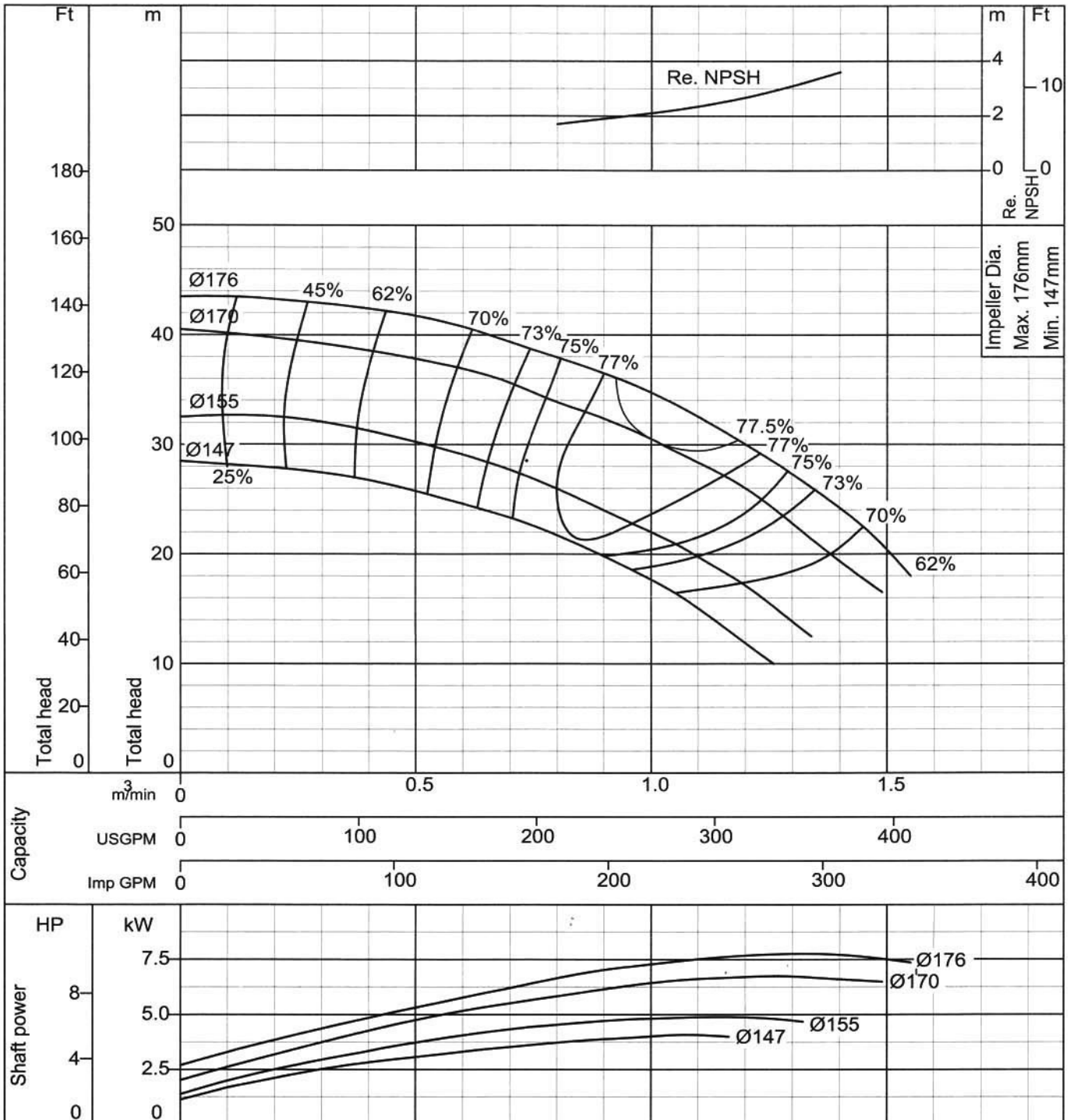

Curve No - 2 - 5FS5604R1

Ebara End Suction Volute Pump

Model FSA

Performance Curve 2 Poles (5/14)

50 Hz

80X65 FS2HA	According to ISO testing code 2548 Class C
50Hz (Approx. speed 2900min ⁻¹)	S.G.= 1.0 Vis.= 1.0 cSt

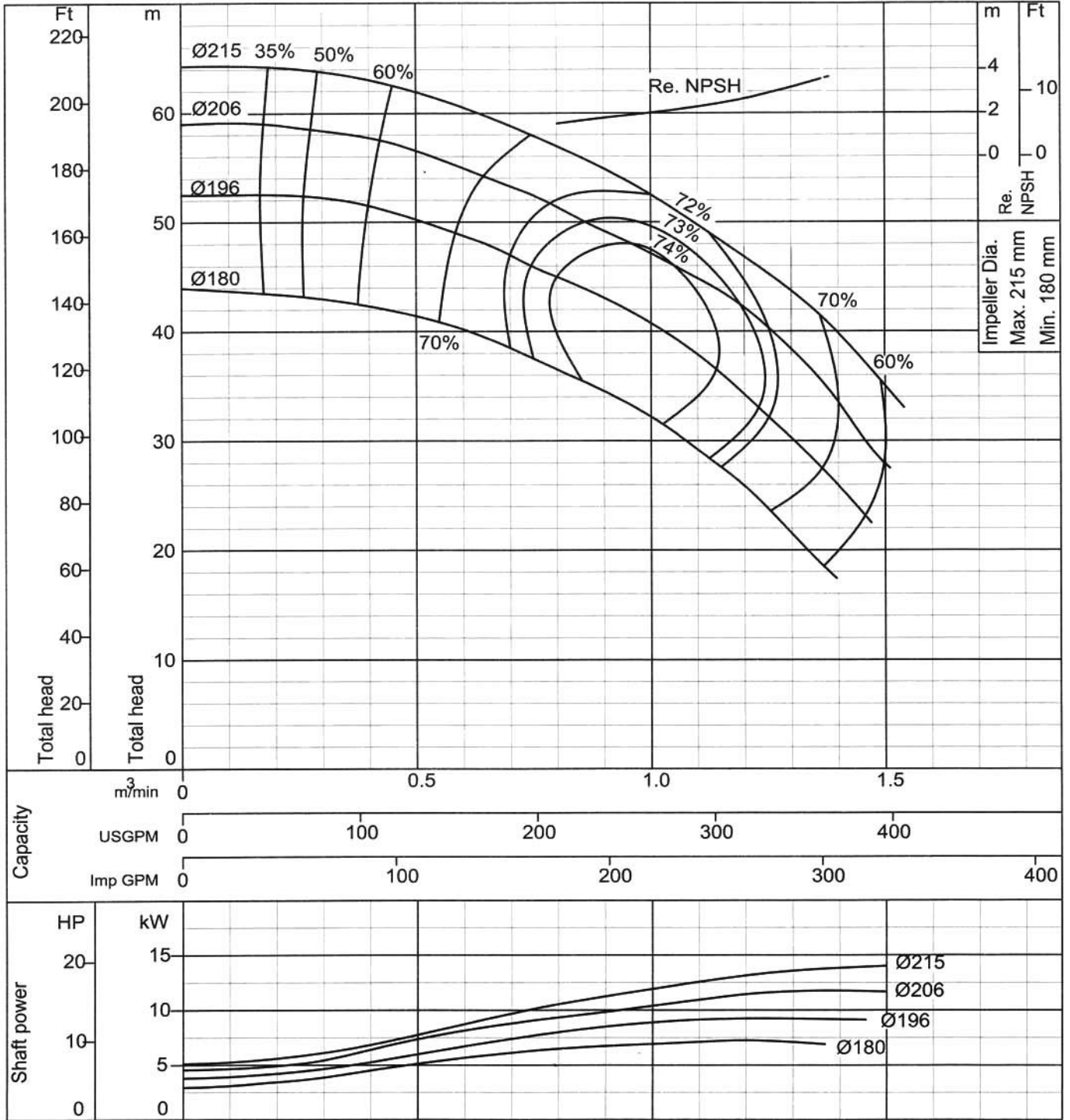

Curve No - 2 - 5FS5605R1

Ebara End Suction Volute Pump

Model FSA

Performance Curve 2 Poles (6/14)

50 Hz

80X65 FS2JA	According to ISO testing code 2548 Class C
50Hz (Approx. speed 2900min ⁻¹)	S.G.= 1.0 Vis.= 1.0 cSt

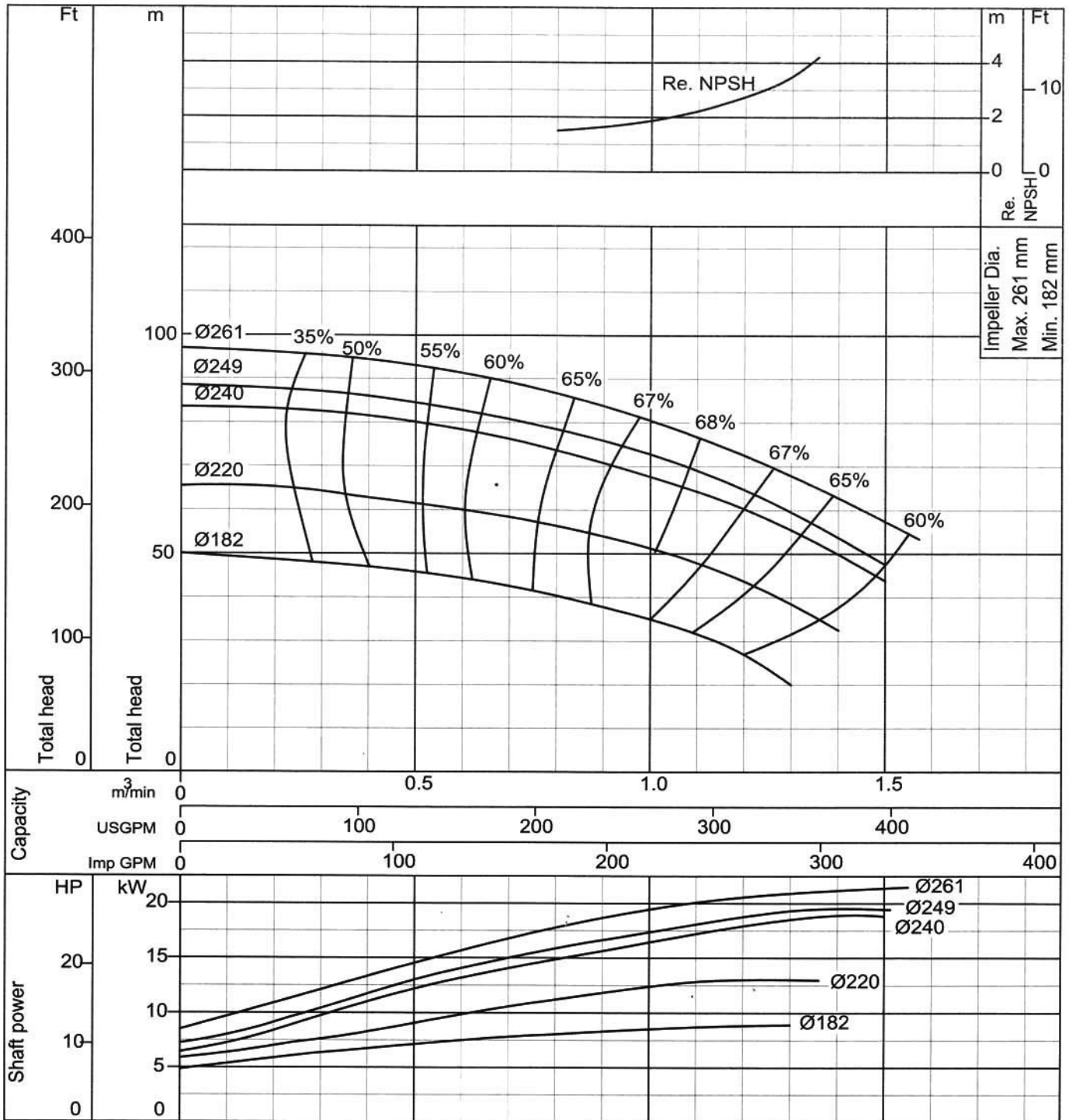

Curve No - 2 - 5FS5606R1

Ebara End Suction Volute Pump

Model FSA

Performance Curve 2 Poles (7/14)

50 Hz

100X80 FS2GA	According to ISO testing code 2548 Class C
50Hz (Approx. speed 2900min ⁻¹)	S.G.= 1.0 Vis.= 1.0 cSt

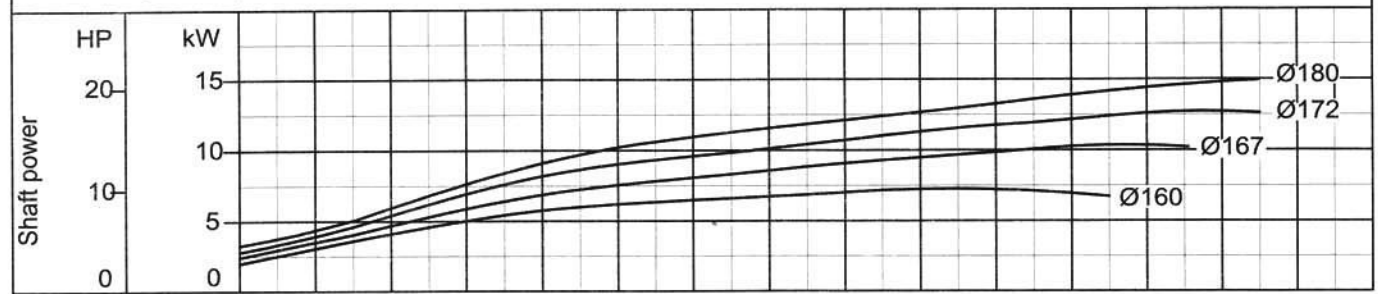
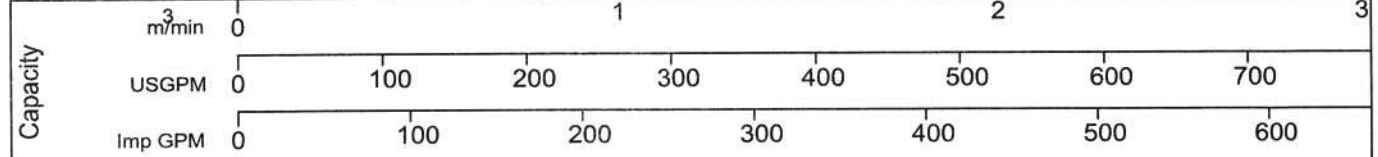
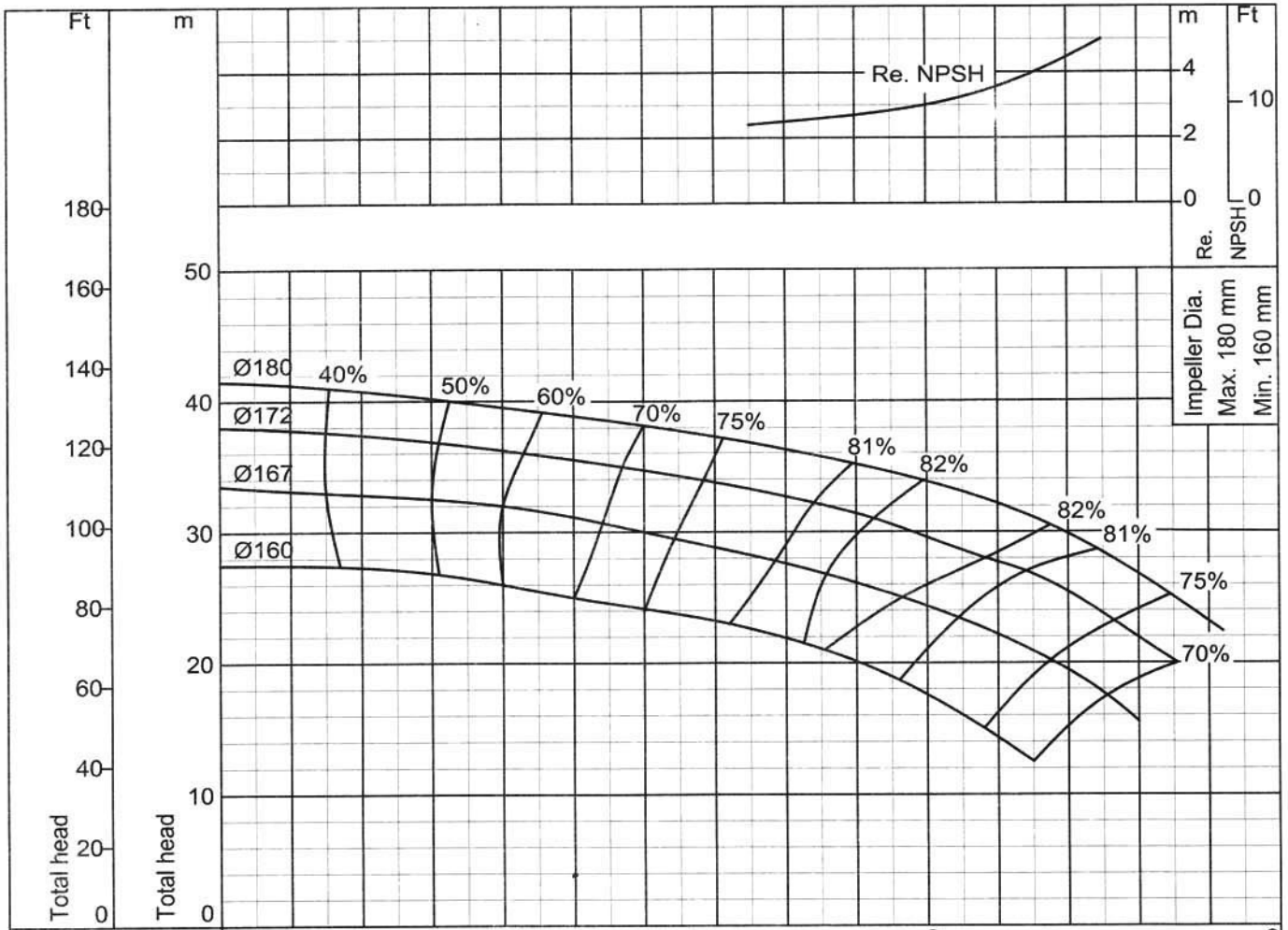

Curve No - 2 - 5FS5607R1

Ebara End Suction Volute Pump

Model FSA

Performance Curve 2 Poles (8/14)

50 Hz

100X80 FS2HA	According to ISO testing code 2548 Class C
50Hz (Approx. speed 2900min ⁻¹)	S.G.= 1.0 Vis.= 1.0 cSt

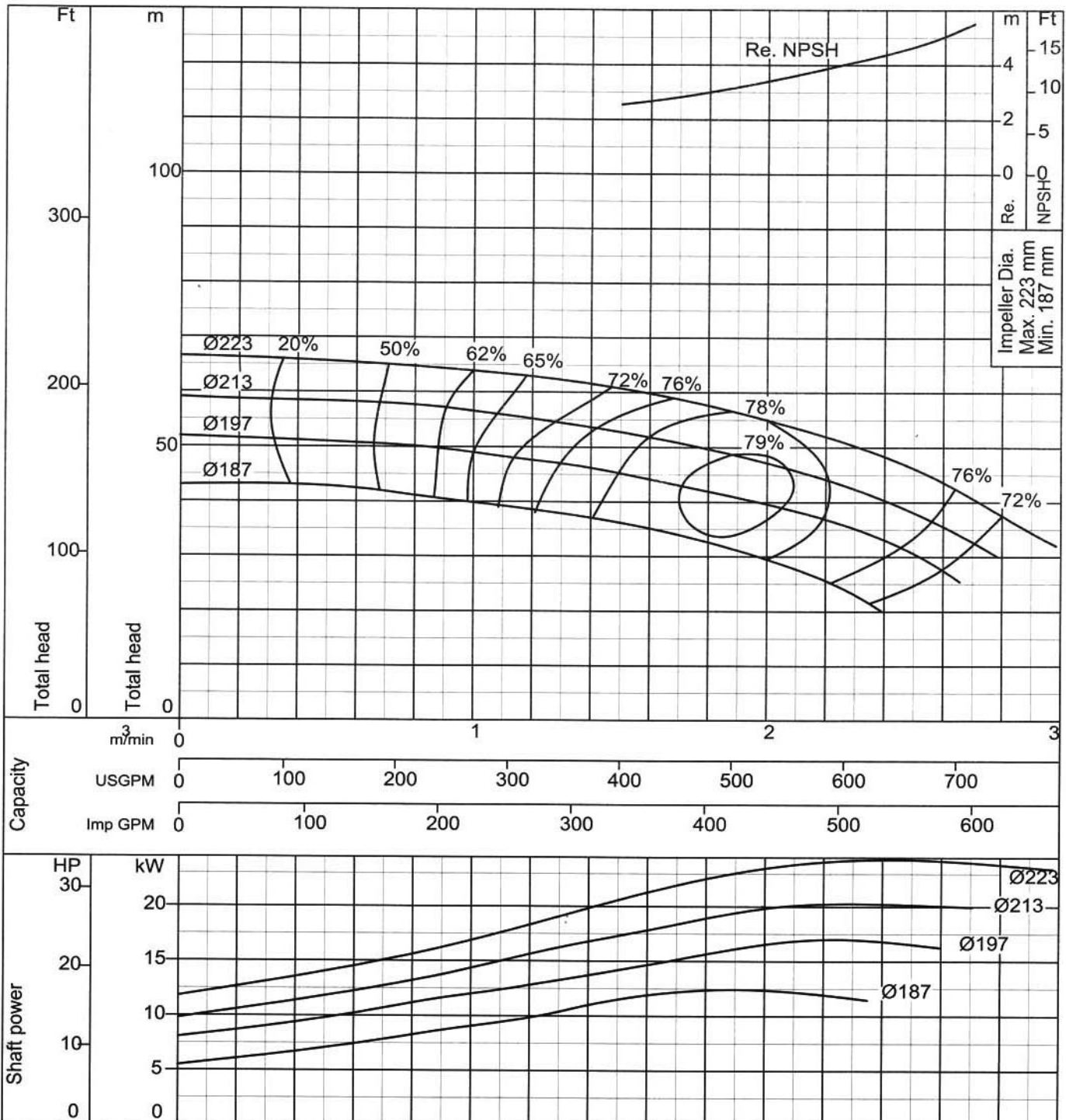

Curve No - 2 - 5FS5608R1

Ebara End Suction Volute Pump

Model FSA

Performance Curve 2 Poles (9/14)

50 Hz

100X80 FS2JA	According to ISO testing code 2548 Class C
50Hz (Approx. speed 2900min ⁻¹)	S.G.= 1.0 Vis.= 1.0 cSt

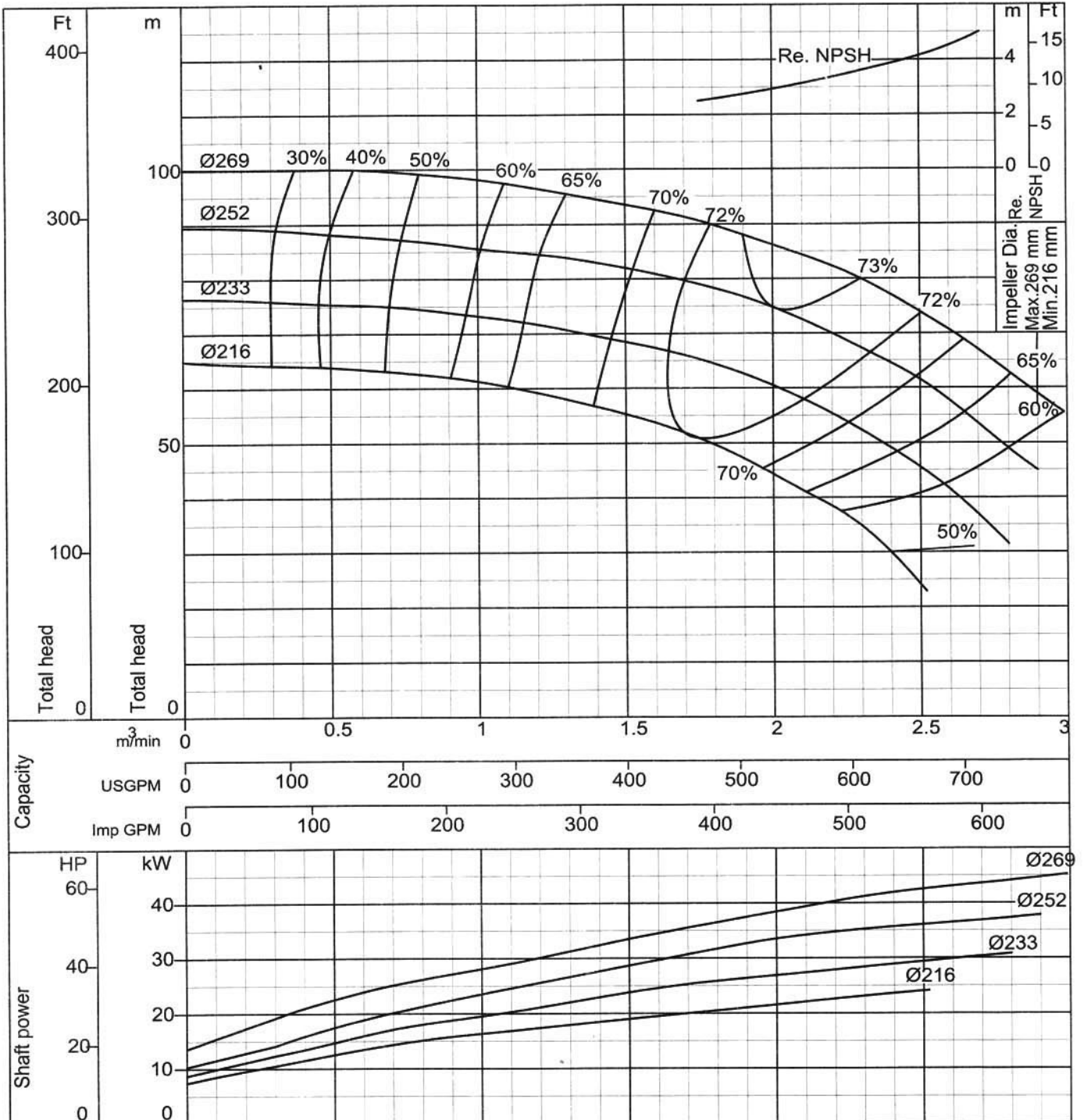

Curve No - 2 - 5FS5609R1

Ebara End Suction Volute Pump

Model FSA

Performance Curve 2 Poles (10/14)

50 Hz

100 x 80 FS2GCA	According to ISO testing code 2548 Class C
50Hz (Approx. speed 2900 min ⁻¹)	S.G.= 1.0 Vis.= 1.0 cSt

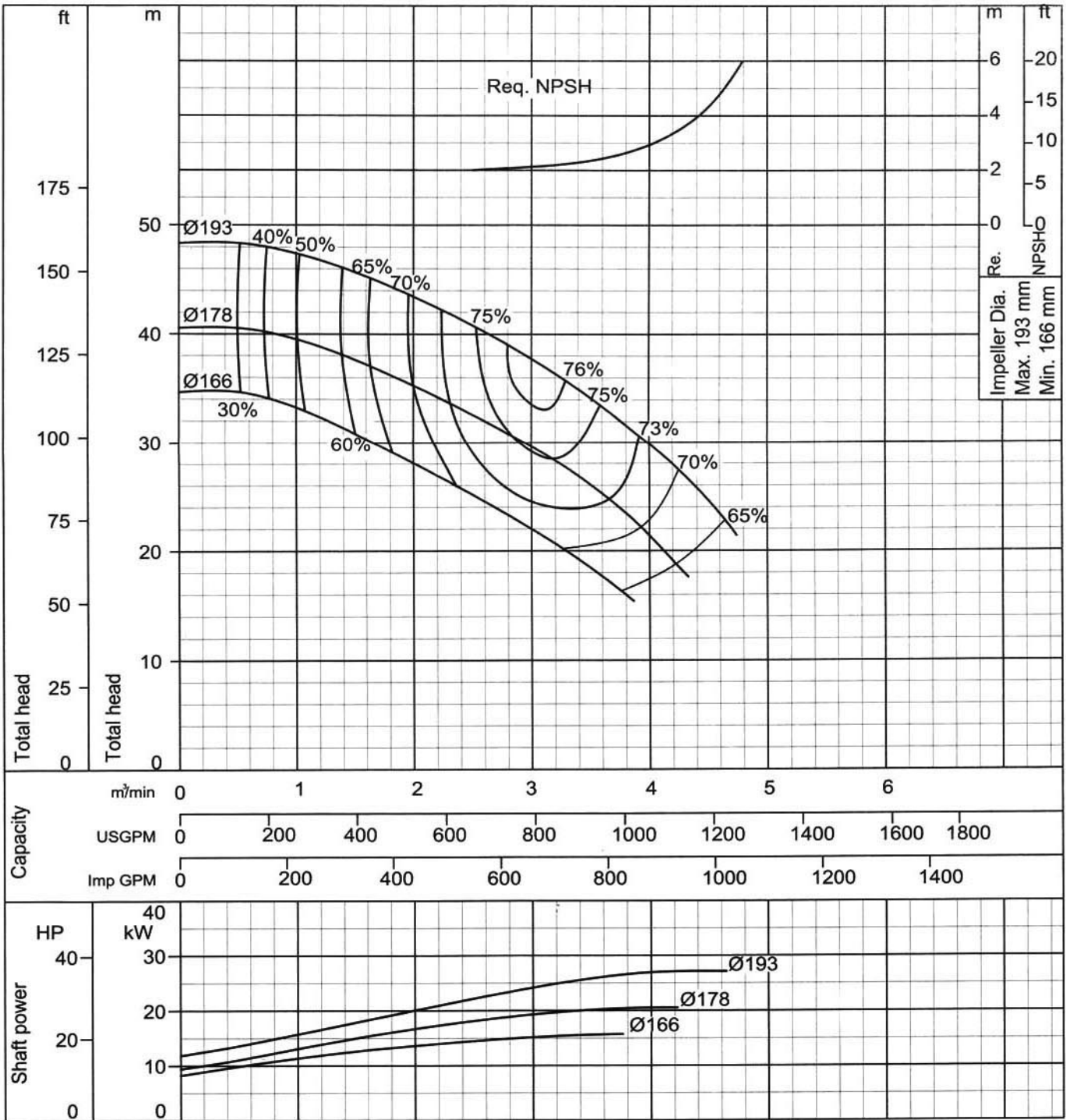

Curve No - 2 - 5FS5610R1

Ebara End Suction Volute Pump

Model FSA

Performance Curve 2 Poles (11/14)

50 Hz

100 x 80 FS2HCA	According to ISO testing code 2548 Class C
50Hz (Approx. speed 2900 min ⁻¹)	S.G.= 1.0 Vis.= 1.0 cSt

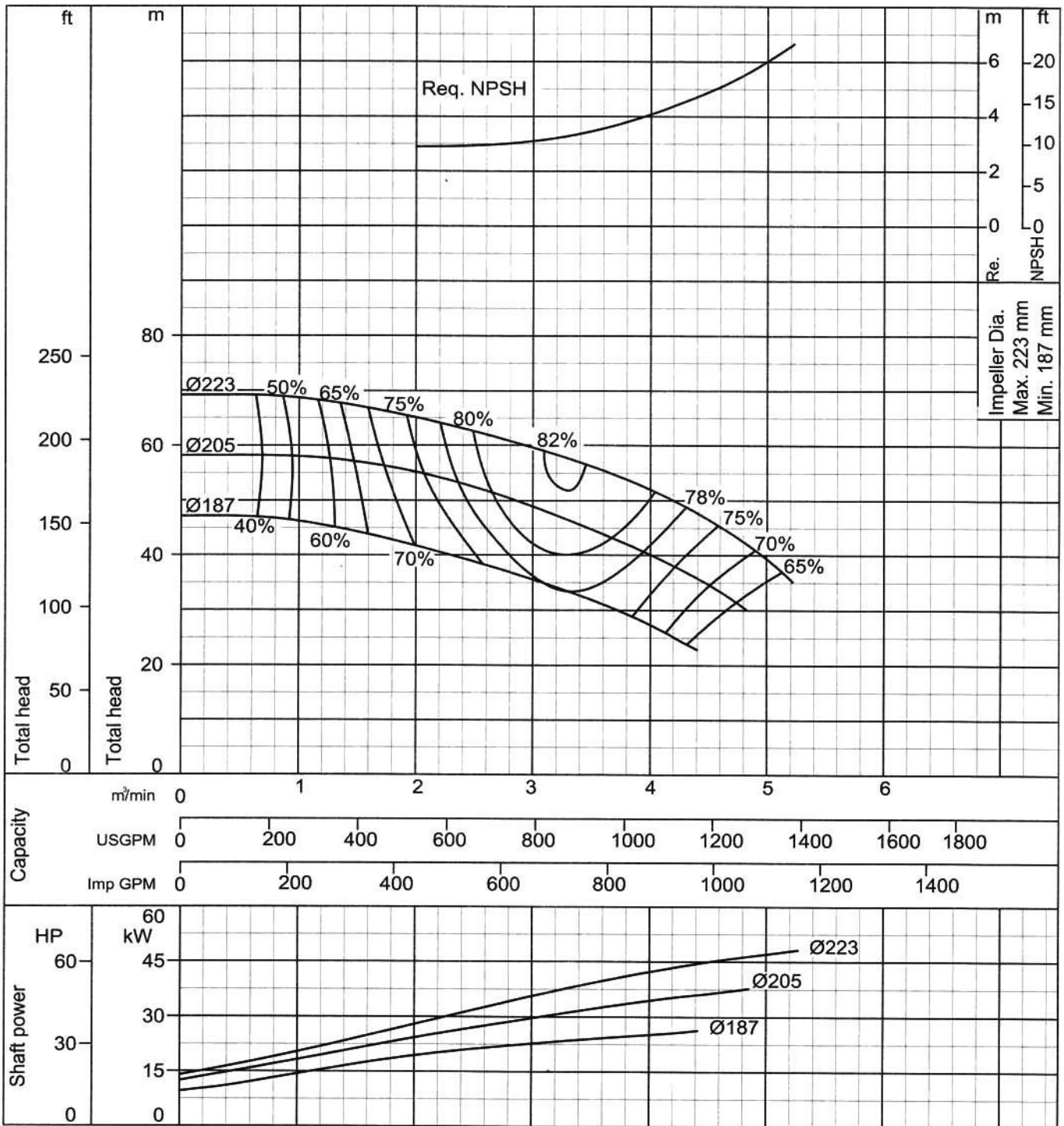

Curve No - 2 - 5FS5611R1

Ebara End Suction Volute Pump

Model FSA

Performance Curve 2 Poles (12/14)

50 Hz

100 x 65 FS2KA	According to ISO testing code 2548 Class C
50Hz (Approx. speed 2900 min ⁻¹)	S.G.= 1.0 Vis.= 1.0 cSt

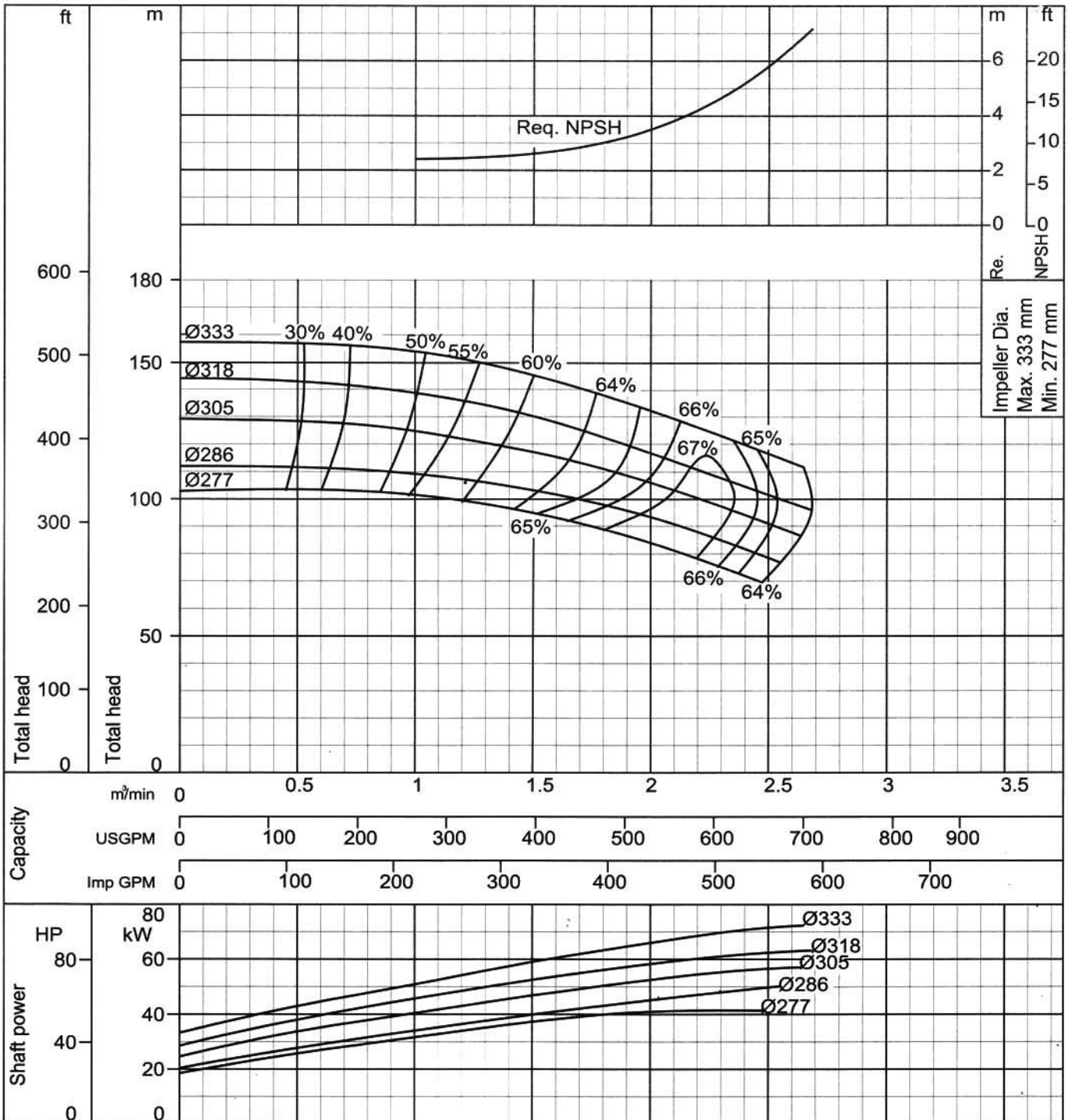

Curve No - 2 - 5FS5612R1

Ebara End Suction Volute Pump

Model FSA

Performance Curve 2 Poles (13/14)

50 Hz

125 x 100 FS2JCA	According to ISO testing code 2548 Class C
50Hz (Approx. speed 2900 min ⁻¹)	S.G.= 1.0 Vis.= 1.0 cSt

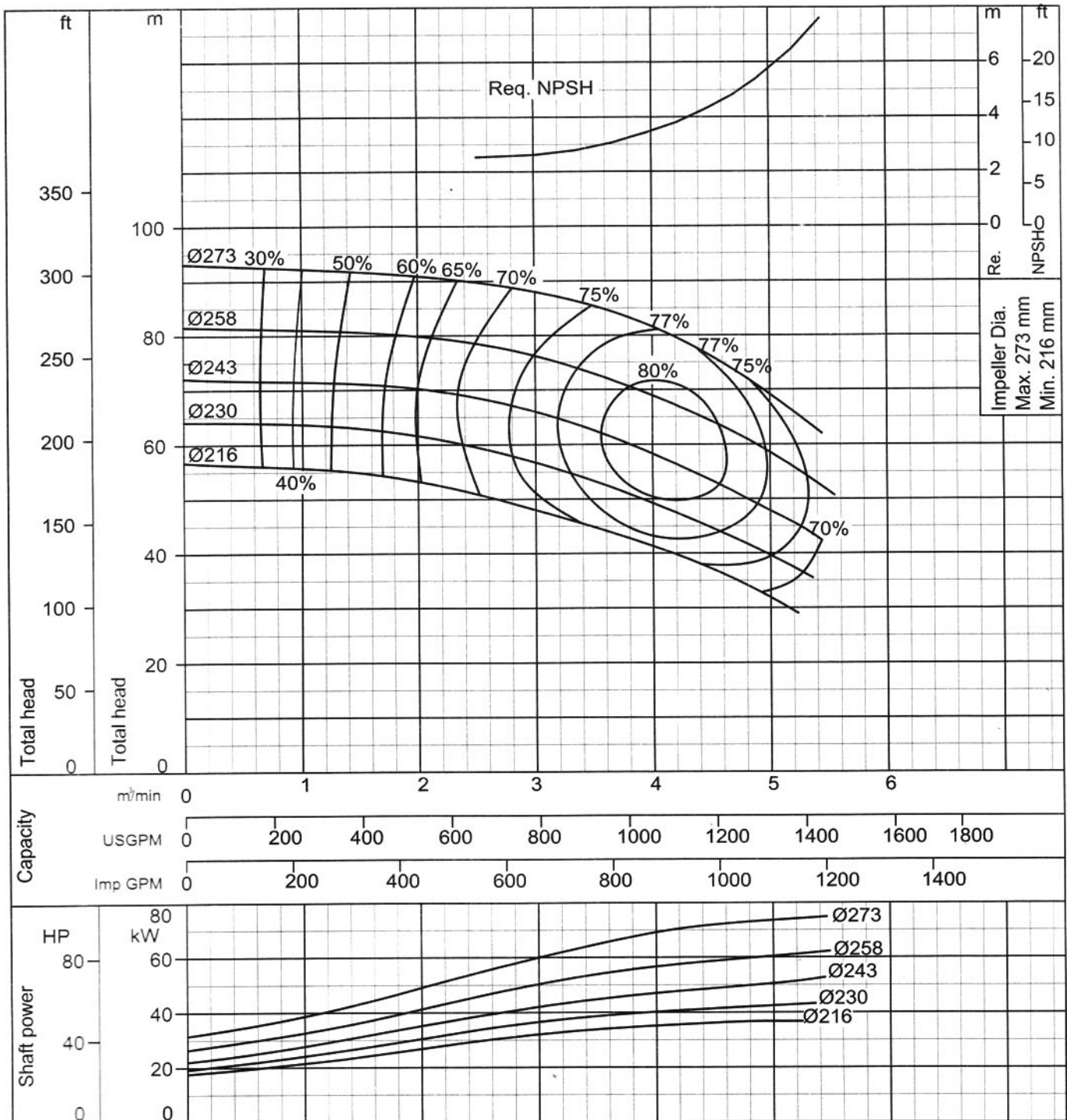

Curve No - 2 - 5FS5613R1

Ebara End Suction Volute Pump

Model FSA

Performance Curve 2 Poles (14/14)

50 Hz

150 x 100 FS2KA

According to ISO testing code 2548 Class C

50Hz (Approx. speed 2900 min⁻¹)

S.G.= 1.0 Vis.= 1.0 cSt

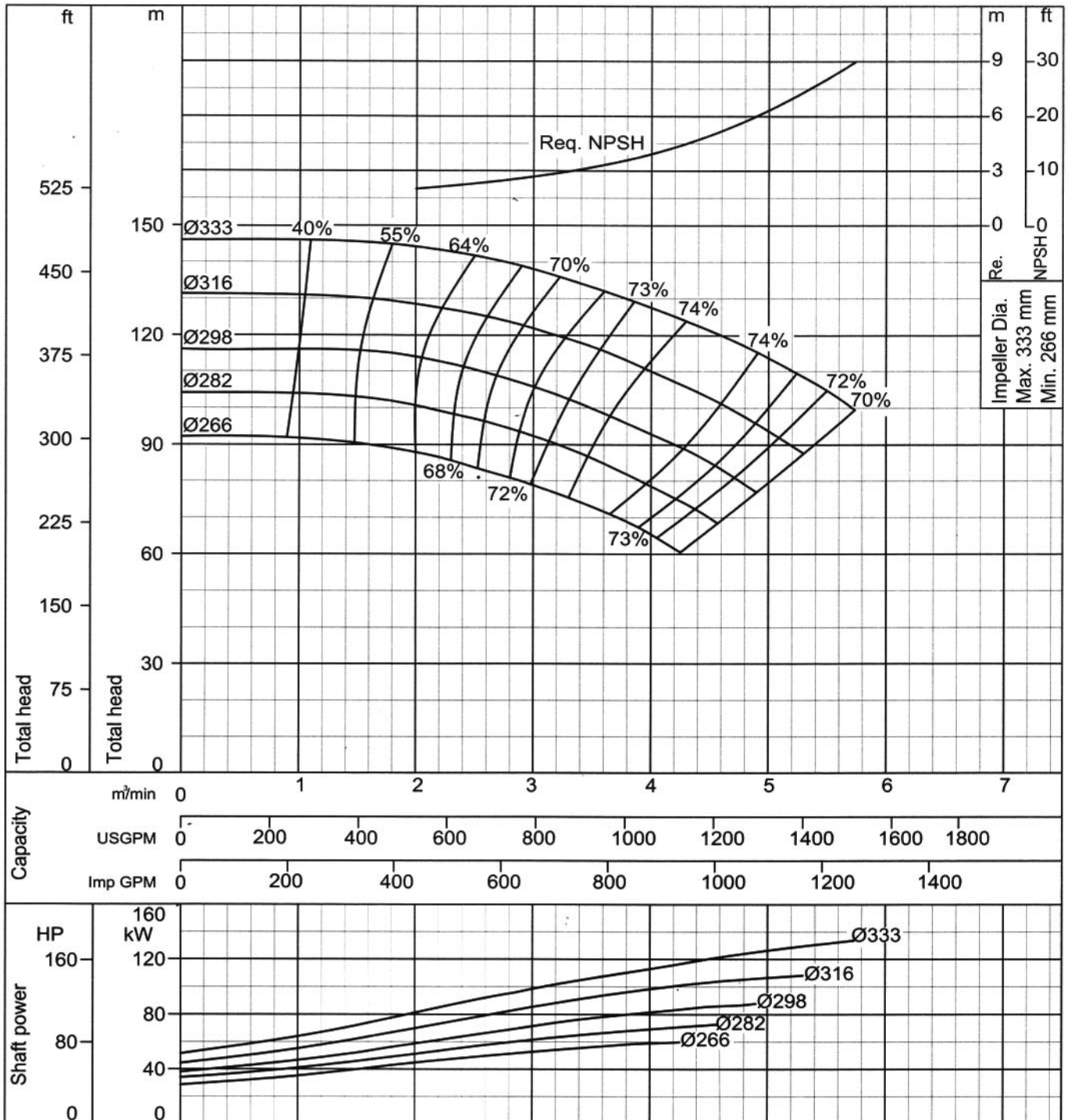

Curve No - 2 - 5FS5614R1



EBARA CORPORATION (Head Office, Standard Pump Business Division), Japan

Website : www.ebara.co.jp/en

EBARA PUMPS EUROPE S.P.A. (Brendola office), Italy

Website : www.ebara-europe.com

E-mail : marketing@ebara-europe.com

SUMOTO S.R.L., Italy

Website : www.sumoto.com

E-mail : info@sumoto.com

EBARA ESPAÑA BOMBAS, S.A., Spain

Website : www.ebara.es

E-mail : correo@ebara.es

EBARA INTERNATIONAL CORPORATION (Standard Pump Division), U.S.A.

Website : www.pumpsebara.com

E-mail : sales@pumpsebara.com

EBARA INDÚSTRIAS MECÂNICAS E COMÉRCIO LTDA, Brazil

Website : www.ebara.com.br

EBARA MACHINERY (CHINA) CO., LTD, P.R.China

Website : www.ebara.cn

E-mail : emc@ebara.cn

EBARA DENSAN-TAIWAN MANUFACTURING CO., LTD, R.O. China-Taiwan

Website : www.ebara.co.tw

E-mail : sales01@ebara.co.tw

EBARA (THAILAND) LIMITED, Thailand

Website : www.ebara.co.th

E-mail : info@ebara.co.th

P.T. EBARA INDONESIA, Indonesia

Website : www.ebaraindonesia.com

E-mail : marketing@ebaraindonesia.com

EBARA PUMPS MALAYSIA SDN. BHD., Malaysia

Website : www.ebara.com.my

E-mail : sales@ebara.com.my

EBARA BENGUET, INC, Philippines

Website : www.ebaraphilippines.com

E-mail : pumpsales@ebaraphilippines.com

EBARA ENGINEERING SINGAPORE PTE. LTD, Singapore

Website : www.ebara.com.sg

EBARA PUMPS AUSTRALIA PTY. LTD., Australia

Website : www.ebara.com.au

PT. LUKES INDONESIA

Lindeteves Trade Center Lt UG, Blok B1 No. 6
Jalan Hayam Wuruk, Jakarta - Indonesia
Phone : 021 - 6231 7842, 628 5144
Fax : 021 - 6231 0499
email : lukes@cbn.net.id

