

PT. LUKES INDONESIA

Lindeteves Trade Center Lt UG, Blok B1 No. 6
Jalan Hayam Wuruk, Jakarta - Indonesia
Phone : 021 - 6231 7842, 628 5144
Fax : 021 - 6231 0499
email : lukes@cbn.net.id



Shaft seals



Contents

Type designation

Type designation to EN 12756	Page	3
Grundfos type designation	Page	5

Shaft seals in general

What is a shaft seal	Page	7
How are shaft seals used	Page	7
Shaft seal components	Page	8
Balanced shaft seal	Page	8
Unbalanced shaft seal	Page	8
Seal balancing	Page	9
How does a shaft seal work	Page	10
Friction, wear and leakage	Page	11
O-ring shaft seals	Page	12
Bellows shaft seals	Page	12
Cartridge shaft seals	Page	13

Shaft seals in viscous liquids

Shaft seals in viscous liquids	Page	14
Recommended shaft seals for viscous liquids	Page	14

Seal face materials

Seal face material combinations	Page	15
Tungsten carbide/tungsten carbide	Page	15
Silicon carbide/silicon carbide	Page	15
Carbon/tungsten carbide or carbon/silicon carbide	Page	16
Carbon/ceramic (aluminium oxide)	Page	16
Tungsten carbide/hybrid	Page	16
Silicon carbide	Page	17

Materials of secondary seals

Secondary seals	Page	21
NBR	Page	21
EPDM	Page	21
FKM	Page	21
FFKM	Page	22
FXM	Page	22
List of pumped liquids	Page	22

Types of shaft seals

Grundfos type A	Page	23
Grundfos type B	Page	24
Grundfos type C	Page	26
Grundfos type D	Page	27
Grundfos type E	Page	28
Grundfos type G	Page	30
Grundfos type H	Page	31
Grundfos type K	Page	34
Grundfos type R	Page	36
Seal arrangements	Page	37
Double seal (back-to-back)	Page	37
Double seal (tandem)	Page	37
Cartex-DE shaft seals	Page	38
Air-cooled top (for high temperatures)	Page	39

Types of shaft seals

Comparing seal types	Page	41
----------------------	------	----

Selection of shaft seals

Selection of the most suitable shaft seal	Page	42
---	------	----

Pumped liquids

Lists of pumped liquids	Page	43
Acids	Page	44
Alkalis	Page	46
Salts	Page	47
Water	Page	49
Coolants	Page	50
Fuels	Page	51
Synthetic and mineral oils	Page	52
Vegetable oils	Page	53
Solvents	Page	54
Oxidants	Page	55
Organic compounds	Page	56
Miscellaneous	Page	57

Failure analysis

Shaft seal failure analysis guide	Page	58
Key to failure analysis	Page	59

Further product documentation

Sources of product documentation	Page	60
WinCAPS	Page	60
WebCAPS	Page	61

Type designation to EN 12756

The EN standard describes the mechanical design of shaft seals and the pairing of materials.

The EN 12756 standard contains

- type key
- material key.

Purpose

Specifications to external Grundfos shaft seal suppliers are made according to the type designation coding system of EN 12 756.

Type designation system

A complete type designation for shaft seals according to EN 12756 consists of

- type code
- material code.

Example	N	U	012	S	0	-	U	B	E	G	G	
Type code												
Material code												

Type key

The EN 12756 contains the following type key:

Example	N	U	012	S	0
Version:					
N = Standard assembly length					
K = Short assembly length					
X = Other assembly length					
Shaft seal type:					
U = Unbalanced					
B = Balanced					
Nominal diameter:					
The diameter (shaft diameter) in mm					
Example: 12 mm shaft = 012					
Direction of rotation:					
R = Right-hand rotation (i.e. clockwise rotation of the seal unit when viewed from the seat)					
L = Left-hand rotation (i.e. counterclockwise rotation of the seal unit when viewed from the seat)					
S = Capability of rotation in either direction					
Retention against rotation of the seat:					
0 = Without retention					
1 = With retention					

Material key

The materials of the individual main components are indicated by means of a material code consisting of five letters.

Example	(1)U	(2)B	(3)E	(4)G	(5)G
Material of rotating seal face					
Material of stationary seat					
Material of secondary seal					
Material of springs					
Material of other components					

Standard codes for material versions

Pos.	Code	Material	
	A	Carbon, metal-impregnated	
	B	Synthetic carbon	
	C		Carbon, resin-impregnated
	D		Other carbons
	D	Carbon steel	
	E	Chromium steel	
	F	Chromium-nickel (CrNi) steel	
	G	Chromium-nickel-molybdenum (CrNiMo) steel	
	H	Metals with carbide coatings	
	K	Metals	
	M		Hard-coating, metallic
	N		High-nickel alloy
	P		Bronze
	R	Grey cast iron	
	S	Alloyed grey cast iron	
(1) and (2)	S	Cast chromium steel	
	T	Other metals	
	U1	Carbides	
	U2		Tungsten carbide, Co-bonded
	U3		Tungsten carbide, Ni-bonded
	U3		Tungsten carbide, CrNiMo-bonded
	Q1		Silicon carbide (SiC)
	Q2		SiC-Si
	Q3		SiC-C-Si, composite
	Q4		C-SiC, surface-siliconised
	J	Other carbides	
	V	Metal oxides	
	W		Aluminium oxide
	X		Chromium oxide
	Y1	Other metal oxides	
	Y2	Plastics	
	Z		PTFE, glass-fibre reinforced
	Z	PTFE, carbon reinforced	
	Z	Other plastics	
	B	Elastomers, not sheathed	
	E		Butyl rubber (IIR)
	K		Ethylene propylene rubber (EPPM)
	N		Perfluoro rubber
	P		Chloroprene rubber (CR)
	S		Nitrile rubber (NBR)
	V		Silicon rubber (MVQ)
	X		Fluoro rubber (FPM)
(3)	X	Other elastomers	
	M	Elastomers, sheathed	
	G		Elastomers/PTFE-sheathed
	T	Non-elastomers	
	Y		Graphite
	Y	PTFE	
	Y	Other non-elastomers	
	U	Various materials	
	U		Various materials for flexible elements
	D	Steel	
	E		Carbon steel
	F		Chromium (Cr) steel
	G		Chromium-nickel (CrNi) steel
	G		Chromium-nickel-molybdenum (CrNiMo) steel
(4) and (5)	M	Alloy	
	N		High-nickel alloy
	T		Copper-tin alloy (bronze)
	T	Other materials	

Example of complete shaft seal type designation

Example	N	U	012	S	O	-	U	B	E	G	G
Standard assembly length											
Unbalanced											
Shaft diameter, 12 mm											
Capability of rotation in either direction											
Without retention against rotation of the stationary seat											
Rotating WC (tungsten carbide) seal face											
Resin-impregnated carbon stationary seat											
EPDM secondary seal											
CrNiMo-steel spring											
All other CrNiMo-steel components											

Grundfos type designation

Mechanical shaft seals are classified according to a Grundfos type designation based on the design of the shaft seal.

Most important materials

The following table shows the codes of the most important materials, selected on the basis of the Grundfos range of products and their fields of application.

Pos.	Code	Material
(1) and (2)	A	Carbon, metal-impregnated
	B	Carbon, resin-impregnated
	H (B/U)	Synthetic carbon Carbon with embedded tungsten carbide (WC) (hybrid)
	C	Other carbons
	D	Steel
	N	Metals Bronze
	S	Cast chromium steel
	U	Tungsten carbide (WC), chromium-nickel-molybdenum-bonded
	Q	Carbides Q ₁ ^S : Dense, sintered, fine-grained silicon carbide (SiC) Q ₁ ^P : Porous, sintered, fine-grained silicon carbide (SiC) Q ₁ ^G : Self-lubricating, sintered silicon carbide (SiC)
	V	Metal oxides Ceramic (aluminium oxide)
(3)	E	EPDM
	F	FXM
	V	FKM
	K	FFKM
	M	PTFE-sheathed O-ring
	P	NBR (nitrile rubber)
	S	Q (silicone rubber)
(4) and (5)	T	PTFE
	X	Other elastomers
	E	Chromium (Cr) steel (EN 1.4057)
	F	Chromium-nickel (CrNi) steel (EN 1.4301)
	G	Chromium-nickel-molybdenum (CrNiMo) steel (EN 1.4401)
M	High-nickel alloy (Hastelloy)	
T	Other alloys	

Stamping code

The stamping code of mechanical shaft seals is stamped on the pump nameplate. Indicated in the last position of the type designation, the stamping code consists of four letters.

Example	(1)A	(2)U	(3)U	(4)E
Grundfos type designation				
Material of rotating face				
Material of stationary seat				
Material of secondary seal				

Position 1 codes

Position 1 of the mechanical shaft seal variant code shows the Grundfos type designation.

The following codes can be shown in position 1:

Code	Description
A	O-ring seal with fixed seal driver
B	Bellows seal, rubber
C	O-ring seal with spring as seal driver
D	O-ring seal, balanced
E	O-ring seal, type A, cartridge
F	Bellows seal, type B, cartridge
G	Bellows seal, type B, with reduced seal faces
H	O-ring seal, type D, cartridge
K	Bellows seal, metal, type M, cartridge
M	Bellows seal, metal
O	Double seal, back-to-back
P	Double seal, tandem
Q	Seal with flush, quench seal
R	O-ring seal, type A, with reduced seal faces
S	Stuffing box
T	Floating gap seal
X	Miscellaneous

Positions 2 and 3 codes

Positions 2 and 3 of the mechanical shaft seal stamping code show materials of rotating face and stationary seat.

The following codes can be shown in positions 2 and 3:

Code	Material
A	Carbon, metal-impregnated
B	Carbon, resin-impregnated
H (B/U)	Synthetic carbon Carbon with embedded tungsten carbide (WC) (hybrid)
C	Other carbons
D	Steel
N	Metals Bronze
S	Cast chromium steel
U	Tungsten carbide (WC), chromium-nickel-molybdenum-bonded
Q	Carbides Q ₁ ^S : Dense, sintered, fine-grained silicon carbide (SiC) Q ₁ ^P : Porous, sintered, fine-grained silicon carbide (SiC) Q ₁ ^G : Self-lubricating, sintered silicon carbide (SiC)
V	Metal oxides Ceramic (aluminium oxide)

Position 4 codes

Position 4 of the mechanical shaft seal stamping code shows the secondary seal material.

The following codes can be shown in position 4:

Code	Material
E	EPDM
F	FXM
V	FKM
K	FFKM
M	PTFE-sheathed O-ring
P	NBR (nitrile rubber)
S	Q (silicone rubber)
T	PTFE
X	Other elastomers

Example of shaft seal stamping code

Example	H	Q	Q	E
Balanced O-ring seal with fixed seal driver (cartridge type)				
Rotating SiC face				
Stationary SiC seat				
Secondary EPDM seal				

Example of stamping code for a complete pump type designation.

Example	CRN	32	-4	-2	-A	-F	-G	-E	HQQE
Type range									
Rated flow [m ³ /h]									
Number of impellers									
Number of reduced-diameter impellers (if any)									
Code for pump version									
Code for pipework connection									
Code for materials									
Code for materials									
Code for shaft seal ¹⁾									

¹⁾ The shaft seal code indicates that the pumps is provided with an O-ring-seal, type H, cartridge, a rotating SiC face, a stationary SiC seat and a secondary EPDM seal.

What is a shaft seal

A shaft seal serves as a barrier in pumps to separate liquids or confine pressure.

How are shaft seals used

Shaft seals are used where the pumped liquid can damage the motor.

Canned rotor type pumps have no shaft seals which means that the pumped liquid is allowed to enter the motor.

The photos below are examples of pumps incorporating rotating shaft seals.

A rotating shaft seal is fitted in the gap between a rotating pump shaft and a stationary pump/motor housing.

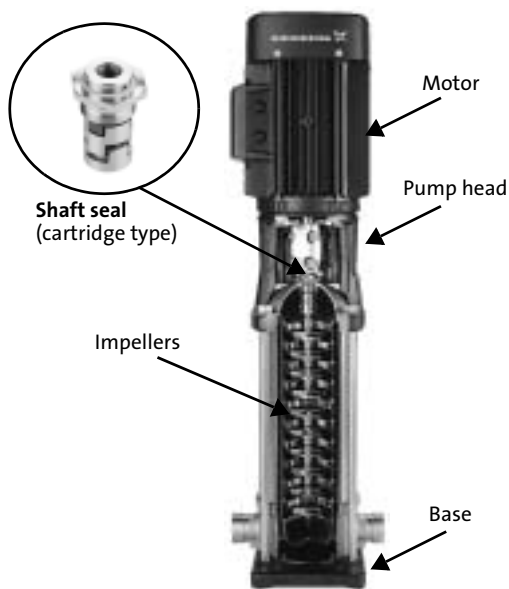

Fig. 1 Shaft seal in a CR pump (in-line pump)

GR5357 - GR3395

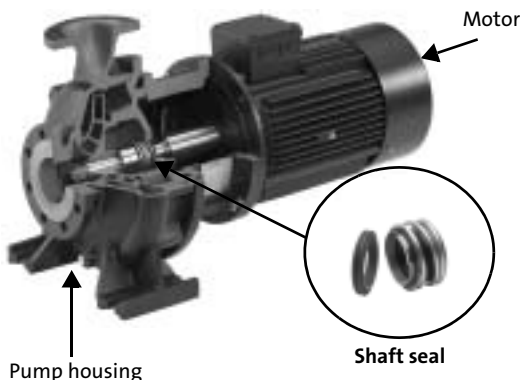

Fig. 2 Shaft seal in an NB pump (end-suction pump)

CR2796 - TM02 7400 3503

Rotating shaft seals

Rotating shaft seals are used where two pump components move relative to one another. Rotating shaft seals include mechanical seals and soft seals (stuffing boxes, lip seals) among others.

Rotating shaft seals

- are exposed to a rotating movement
- form during operation a load-carrying lubricating film between the seal faces of the rotating and stationary part of the shaft seal. For further information, see "How does a shaft seal work" on page 10.

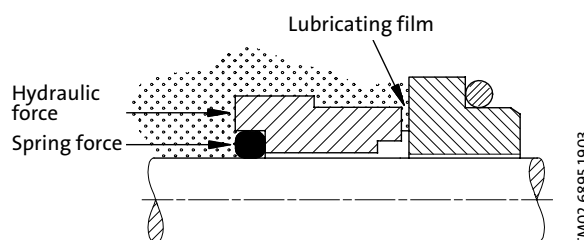

TM02 6895 1903

Fig. 3 Rotating shaft seal

In practice, no seal is completely tight. Leakage is influenced by factors such as the ability of the pumped liquid to penetrate the shaft seal, the fluctuating hydrodynamic gap pressure between the seal faces, the topography of the surface and the hydraulic closing force.

It is essential that both static and rotating seals are not only resistant to the liquid they are to seal against but also capable of withstanding the impacts resulting from the operation of the pump.

The choice of shaft seal depends on

- the liquid the seal is to seal against
- the liquid properties
- the mechanical, chemical and thermal impacts on the seal.

Shaft seal components

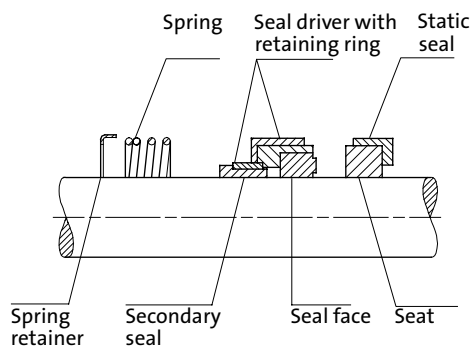

TM02 6889 1903

Fig. 4 Components of mechanical shaft seals

Key:

Shaft seal	Designation
	Spring
	Seal driver with retaining ring
Rotating part	Spring retainer
	Secondary seal
	Seal face
Stationary part	Static seal (secondary seal)
	Seat (primary seal)

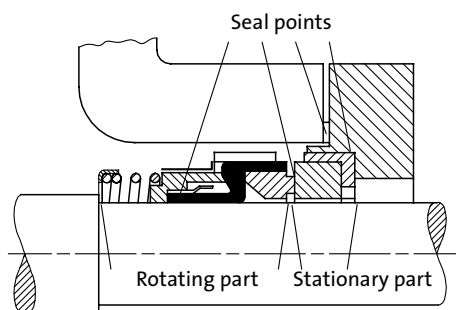

TM02 6890 1903

Fig. 5 Main components of a mechanical shaft seal

A mechanical shaft seal consists of a

- rotating part
- stationary part.

The rotating part comprises a seal face (primary seal), a seal driver with retaining ring, a secondary seal, a spring and a spring retainer.

The stationary part consists of a seat (primary seal) and a static seal (secondary seal).

The parts mentioned above are crucial for the proper functioning of the shaft seal.

Primary seals differ from the other components in that they are exposed to a powerful axial spring force and to the liquid pressure in the seal housing during the rotation of the seal faces relative to one another. The spring keeps the seal faces together mechanically.

To obtain an acceptable surface pressure between the primary seal faces, shaft seals are available in two different designs:

- balanced shaft seals
- unbalanced shaft seals.

Balanced shaft seal

The sketch below shows a balanced shaft seal with indication of the forces acting on the seal faces.

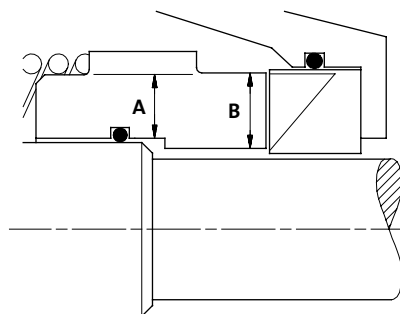

TM02 6892 1903

Fig. 6 Areas where the forces of a balanced seal act

Unbalanced shaft seal

The sketch below shows an unbalanced shaft seal with indication of the forces acting on the seal faces.

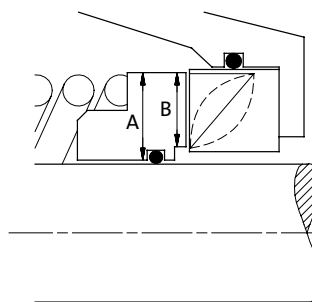

TM02 6891 1903

Fig. 7 Areas where the forces of an unbalanced seal act

Seal balancing

Calculation formulas

Formula for calculation of the balancing K-factor:

$$K = \frac{A}{B}$$

Formula for calculation of the closing force (F_C):

$$F_C = (A \times P) + F_S \quad [\text{N}]$$

Formula for calculation of the opening force (F_O):

$$F_O = B \times \frac{P}{2} \quad [\text{N}]$$

Formula for calculation of the efficient closing force ($F_{C, \text{eff}}$):

$$F_{C, \text{eff.}} = F_C - F_O \quad [\text{N}]$$

Formula for calculation of the efficient seat pressure (P_{eff}):

$$P_{\text{eff.}} = \frac{F_{C, \text{eff.}}}{B} \quad [\text{N}]$$

Key to symbols:

Symbol	Description	Note
A	Area in mm ²	See sketch of balanced and unbalanced shaft seal, see page 8.
B	Area in mm ²	See sketch of balanced and unbalanced shaft seal, see page 8.
P	Pressure around shaft seal in N/mm ²	
F _S	Spring force in N	

Calculation example, unbalanced shaft seal, Grundfos type B

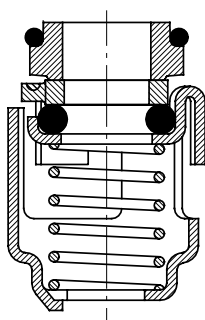

TM00 2581 4593

Fig. 8 Grundfos shaft seal, type B

Data:

A	180 mm ²
B	150 mm ²
F _S	45 N
P	0.8 N/mm ²

Calculation of the balancing K-factor:

$$K = \frac{180}{150} \quad K = 1.2$$

Calculation of forces acting on the shaft seal:

Calculation of the closing force (F_C):

$$F_C = (180 \times 0.8) + 45 \quad F_C = 189 \text{ [N]}$$

Calculation of the opening force (F_O):

$$F_O = 150 \times \left(\frac{0.8}{2}\right) \quad F_O = 60 \text{ [N]}$$

Calculation of the efficient closing force ($F_{C, \text{eff}}$):

$$F_{C, \text{eff.}} = 189 - 60 \quad F_{C, \text{eff.}} = 129 \text{ [N]}$$

Calculation of the efficient seat load (P_{eff}):

$$P_{\text{eff.}} = \frac{129}{150} \quad P_{\text{eff.}} = 0.86 \text{ [N/mm}^2\text{]}$$

Calculation example, balanced shaft seal, Grundfos type H

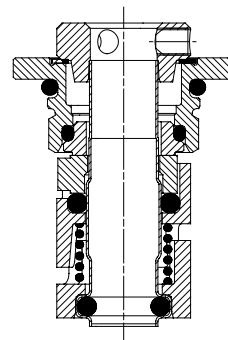

TM02 7100 2603

Fig. 9 Grundfos shaft seal, type H

Data:

A	150 mm ²
B	150 mm ²
F _S	45 N
P	0.8 N/mm ²

Calculation of the balancing K-factor:

$$K = \frac{150}{150} \quad K = 1.0$$

Calculation of forces acting on the shaft seal:

Calculation of the closing force (F_C):

$$F_C = (150 \times 0.8) + 45 \quad F_C = 165 \text{ [N]}$$

Calculation of the opening force (F_O):

$$F_O = 150 \times \left(\frac{0.8}{2}\right) \quad F_O = 60 \text{ [N]}$$

Calculation of the efficient closing force ($F_{C, \text{eff}}$):

$$F_{C, \text{eff.}} = 165 - 60 \quad F_{C, \text{eff.}} = 105 \text{ [N]}$$

Calculation of the efficient seat load (P_{eff}):

$$P_{\text{eff.}} = \frac{105}{150} \quad P_{\text{eff.}} = 0.70 \text{ [N/mm}^2\text{]}$$

Calculation example, balanced shaft seal, Grundfos type K

Data:

A	120 mm ²
B	150 mm ²
F _s	45 N
P	0.8 N/mm ²

Calculation of the K-factor:

$$K = \frac{120}{150} \quad K = 0.8$$

Calculation of forces acting on the shaft seal:

Calculation of the closing force (F_C):

$$F_C = (120 \times 0.8) + 45 \quad F_C = 141 \text{ [N]}$$

Calculation of the opening force (F_O):

$$F_O = 150 \times \left(\frac{0.8}{2}\right) \quad F_O = 60 \text{ [N]}$$

Calculation of the efficient closing force ($F_{C, \text{eff}}$):

$$F_{C, \text{eff.}} = 141 - 60 \quad F_{C, \text{eff.}} = 81 \text{ [N]}$$

Calculation of the efficient seat pressure (P_{eff}):

$$P_{\text{eff.}} = \frac{81}{150} \quad P_{\text{eff.}} = 0.54 \text{ [N/mm}^2\text{]}$$

Depending on the shaft diameter and the material of the stationary seat, unbalanced shaft seals are suitable for applications up to 25 bar.

Balanced seals are suitable for applications up to 80 bar. This is possible on account of the smaller load on the seal faces effected by means of a recess on the shaft or a bush, reducing the external and internal diameter of the rotating seal face. The purpose is to reduce the area affected by the hydraulic pressure in the seal housing without changing the area between the seal faces.

The smaller load on the seal faces causes less heat to be generated, meaning less friction and mechanical wear on the shaft seal. This improves the cost of ownership of the shaft seal.

For balanced shaft seals, the following applies:

$$K = \frac{A}{B} \leq 1 \text{ [-]}$$

For unbalanced shaft seals, the following applies:

$$K = \frac{A}{B} > 1 \text{ [-]}$$

Key to symbols:

K	Area ratio
A	The hydraulically loaded area in mm ²
B	Contact face in mm ²

How does a shaft seal work

The functioning of a shaft seal depends on the formation of a load-carrying lubricating film between the seal faces during pump operation. The lubricating film is formed by the pumped liquid or an external liquid.

The load-carrying lubricating film is composed of a

- hydrostatic film
- hydrodynamic film.

The **hydrostatic** lubricating film is formed in one of the following ways:

- during operation, the **pumped liquid** is pressed into the gap between the seal faces
- during operation, an **external liquid** is pressed into the gap between the seal faces.

The **hydrodynamic** lubricating film is formed by the pressure generated by the rotation of the shaft.

The thickness of the lubricating film depends on pump speed, liquid temperature, liquid viscosity and the axial force of the seal.

As the shaft seal is pressed together axially, the leakage to the atmosphere is limited.

The sealing liquid in the sealing gap is constantly replaced due to

- vapourisation of the liquid to the atmosphere
- the circular movements of the liquid.

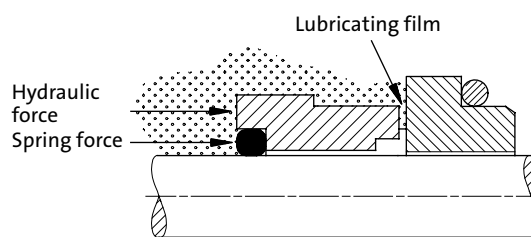

TM02 6895 1903

Fig. 10 Shaft seal during operation

Friction, wear and leakage

The seal face of a shaft seal is lubricated by the pumped liquid. Thus, better lubrication means less friction and increased leakage. Conversely, less leakage means worse lubrication conditions and increased friction.

The following factors contribute to the power consumption ("power loss") of a shaft seal:

- The centrifugal pumping action of the rotating parts. The power consumption increases dramatically with the speed of rotation (to the third power).
- The seal face friction. Friction between the two seal faces consists of friction in the thin liquid film and friction due to points of contact between the seal faces.

The level of power consumption depends on seal design, lubricating conditions and seal ring materials.

The figure below is a typical example of the power consumption of a shaft seal operating in cold water. The figure shows the power loss of each of the power consumption factors as a function of the speed.

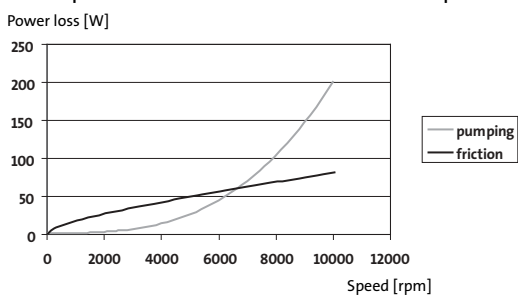

Fig. 11 Power consumption of seal

According to the figure, the power loss due to the pumping action of rotating parts may be considerable at high speeds. This applies for example to shaft seals with seal driver. Thus, with speeds above 6000 rpm, it may be an advantage to use shaft seals where seal driver and springs are positioned in the stationary part of the seal.

The thickness of the lubricating film in the sealing gap depends on the

- liquid viscosity
- speed of the seal rings
- closing force of the shaft seal
- pressure difference across the sealing gap
- surface topography of the seal faces.

The viscosity of water decreases with temperature, causing a reduction of the lubricating film. When the temperature exceeds +100°C, the lubricating conditions deteriorate substantially because a considerable part of the seal face is steam lubricated. Thus friction and wear on the seal rings increase with temperature. To prevent excessive wear, the closing force and differential pressure can be reduced by balancing the seal.

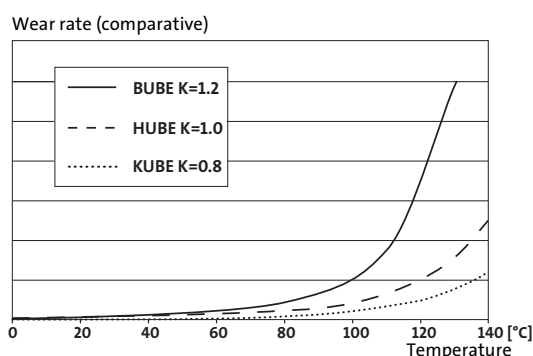

Fig. 12 Wear rate for different balancing ratios

The thickness of the lubricating film in the sealing gap is sensitive to the flatness of the seal faces. An unevenness of 0.001 mm results in leakage.

The figure below shows how the leakage rate of a shaft seal in water changes with the flatness of the seal rings.

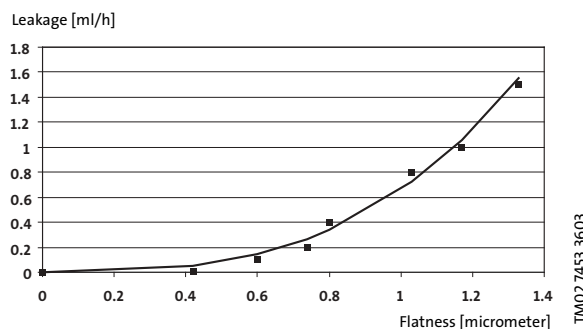

Fig. 13 Flatness as a function of leakage

With an unevenness of 0.001 mm, a hard seal ring (WC or ceramic material) has increased leakage during a typical running-in period of several weeks. If the seal ring surface is less uneven, the running-in period is considerably shorter.

The leakage rate of a shaft seal is also greatly influenced by the roughness of the seal faces; both the roughness size and direction are critical.

Figure 15 shows how the leakage rate differs according to the direction of the scratches on the surface. The arrows indicate the direction of rotation of the seal rings.

According to the figure below, the lubricating film can be pumped to the pumped liquid side or to the atmosphere side, depending on the direction of the scratches on the surface.

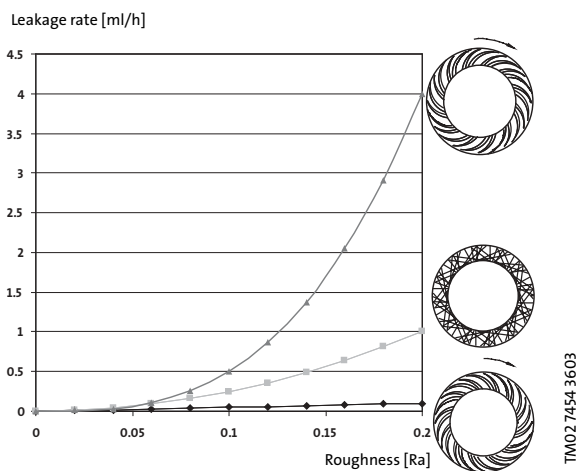

Fig. 14 Leakage rate of seal

The typical surface topography of seal rings is a statistic distribution of scratches in all directions obtained by means of a lapping process. A shiny surface with a small roughness can be produced by lapping. However, where both seal rings are in hard materials, one of the seal rings should have a dull finish to prevent the seal rings from sticking together during standstill.

The running-in period for a dull surface finish lapped to an Ra value of 0.2 may last several days.

With submersible pumps where the shaft seal is intended to prevent the ingress of water into an oil chamber, the pressure difference and thus the leakage rate above the seal is normally relatively small. During the running-in period, only few millimetres of oil enter the oil chamber under normal operating conditions.

O-ring shaft seals

In an O-ring seal, sealing between the rotating shaft and the rotating seal face is effected by an O-ring.

The O-ring must be able to slide freely in the axial direction to absorb axial displacements as a result of changes in temperatures and wear. Incorrect positioning of the stationary seat may result in rubbing and thus unnecessary wear on the O-ring and on the shaft.

O-rings are made of different types of rubber material such as NBR, EPDM and FKM, depending on the operating conditions.

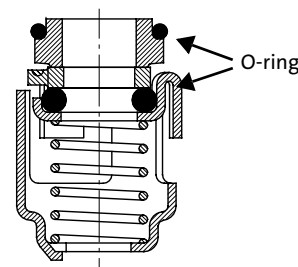

Fig. 15 O-ring shaft seal

Advantages and disadvantages

- Advantages:** Suitable in hot water and high pressure applications.
- Disadvantages:** Deposits on the shaft such as rust etc. may prevent the O-ring shaft seal from moving axially.

Bellows shaft seals

A common feature of bellows mechanical seals is a rubber or metal bellows as dynamic sealing element between the rotating ring and the shaft.

Rubber bellows shaft seals

The bellows of a rubber bellows mechanical seals is made of different types of rubber material such as NBR, EPDM and FKM, depending on the operating conditions.

Two different geometric principles are used for the design of rubber bellows;

- folding bellows
- rolling bellows.

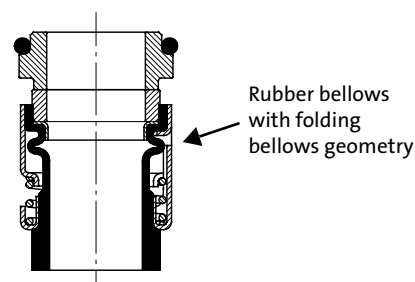

Fig. 16 Rubber bellows shaft seal

Advantages and disadvantages

- Advantages:** Not sensitive to deposits such as rust etc. on the shaft. Suitable for pumping solid-containing liquids.
- Disadvantages:** Not suitable in hot water and high-pressure applications.

Metal bellows shaft seals

In an ordinary mechanical seal, the spring produces the closing force required to close the seal faces. In a metal bellows mechanical seal the spring has been replaced by a metal bellows with a similar force.

Metal bellows act both as a dynamic seal between the rotating ring and the shaft and as a spring.

The bellows have a number of corrugations to give the bellows the desired spring force.

The corrugations are available in stainless steel, matching the operating conditions.

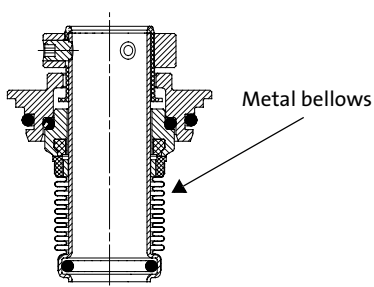

Fig. 17 Metal bellows shaft seal

Advantages and disadvantages

- Advantages:**
- Not sensitive to deposits such as rust, lime etc. on the shaft.
 - Suitable in hot water and high-pressure applications.
 - Long life due to a low wear rate and a low balancing rate (cost of ownership).
- Disadvantages:**
- Fatigue failure of the shaft seal may occur when the pump is not aligned correctly.
 - Fatigue may occur as a result of excessive temperatures or pressures.

Cartridge shaft seals

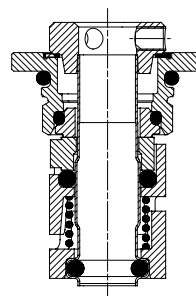

Fig. 18 Cartridge shaft seal

In a cartridge shaft seal, all parts form a compact unit on a shaft sleeve, ready to be installed between pump shaft and motor shaft.

A cartridge seal offers many benefits compared to conventional shaft seals:

- Easy and fast service
- The design protects the seal faces
- Preloaded spring
- Safe handling
- Balanced.

Grundfos offers O-ring and bellows seals in cartridge design.

Shaft seals in viscous liquids

With the basic principles of the mechanical shaft seal in mind, it seems logical that a high-viscous liquid creates a thicker liquid film with better lubricating properties. However, the following shaft seal problems may occur when pumping viscous liquids:

- If it has a vapour pressure lower than that of water at room temperature, the viscous liquid will not evaporate. Consequently, it accumulates around the shaft seal. This problem can be solved by using a double shaft seal. For further information see page 37.
- If the liquid contains solvents, these will evaporate and leave an even more viscous liquid in the shaft seal. This high-viscous liquid may precipitate a coating on the seal faces causing leakage or abrasive wear. This problem can be solved by using carbide/carbide seal faces or a double shaft seal. For further information see page 15 and page 37.
- Coolants such as glycols often contain additives (corrosion inhibitors) that may precipitate and crystallize on the seal faces causing abrasive wear. Therefore it is recommended to use carbide/carbide seal faces for all coolants. For further information see page 15.

Recommended shaft seals for viscous liquids

Seal face materials

It is recommended to use carbide/carbide seal faces for pumping viscous liquids. Grundfos carbide seal faces are made of either silicon carbide (code Q) or tungsten carbide (code U).

Seal faces made of impregnated carbon (code A or B) are not recommended due to their lack of abrasion resistance.

Surface pressure

To minimize precipitation, it is important to ensure a high surface pressure between the seal faces. This can be achieved by reducing the seal face area (R- or G-seals) or by providing the seal with a tight spring. In shaft seals with a high surface pressure the seal faces have considerably smoother surface than ordinary shaft seals.

Recommended shaft seal codes for viscous liquids

Description	Shaft seal code
Type A seals O-ring seal with fixed seal driver	AUUE AUUV AQQE AQQV
Type B seals Bellows seal with fixed seal driver	BQQE BQQV BUUE BUUV
Type D seals O-ring seal, balanced	DQQE DQQV
Type E seals O-ring seal, type A, cartridge	EUUE EUUV EQQE EQQV
Type G seals Bellows seal, type B, with reduced seal faces	GUUE GUUV GQQE GQQV
Type H seals O-ring, type D, cartridge	HUUE HUUV HQQE HQQV
Type R seals O-ring seal, type A, with reduced seal faces	RUUE RUUV

Seal face material combinations

The choice of seal face materials is decisive of the function and life of the mechanical shaft seal. Below is a description of the possible material pairings.

Noise is generated as a result of the poor lubricating conditions in seals with low-viscosity liquids. The viscosity of water decreases with increasing temperature. This means that the lubricating conditions are deteriorated with increasing temperature. A speed reduction has the same effect.

If the pumped liquid reaches or exceeds boiling temperature, the liquid on part of the seal face evaporates, resulting in a further deterioration of the lubricating conditions.

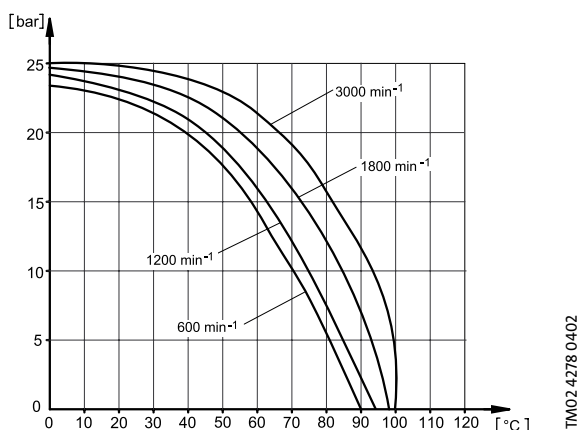

Fig. 19 Relation between duty range and speed

The seal face lubricating conditions depend on the adaptation/running-in wear properties and material structure of the various seal face materials.

Tungsten carbide/tungsten carbide

Cemented tungsten carbide is the designation of the type of hard metals based on a hard tungsten carbide (WC) phase and usually a softer metallic binder phase. The correct technical term is "cemented tungsten carbide", however the abbreviated term "tungsten carbide" (WC) is used for convenience, "cemented" being understood.

Cobalt-bonded (Co) WC is only corrosion-resistant in water if the pump incorporates base metal such as cast iron.

Chromium-nickel-molybdenum-bonded WC has a corrosion resistance equal to EN/DIN 1.4401.

Sintered binderless WC has the highest resistance to corrosion, although it is not resistant in substances such as hypochlorite.

The material pairing has the following features:

- Extremely wear resistant.
- Very robust, resists rough handling.
- Poor dry-running properties. In case of dry running, the temperature increases to several hundred degrees Celsius in very few minutes with a consequent damage to O-rings.

If certain pressure and temperature limits are exceeded, the seal may generate noise. The noise is an indication of poor seal operating conditions, causing wear of the seal in the long term. The limits of use depend on seal diameter and design.

The pressure/temperature diagrams of the various seals show areas where noise may occur.

To a WC/WC seal face pairing, the running-in wear period with noise may last 3 - 4 weeks, although, typically, no noise occurs during the first 3 - 4 days.

Silicon carbide/silicon carbide

Being an alternative to WC/WC, silicon carbide/silicon carbide (SiC/SiC) is used where higher corrosion resistance is required.

For differentiation purposes, the various variants are designated as indicated below.

Q₁^S, dense, sintered, fine-grained SiC

A direct-sintered fine-grained SiC with a small amount of tiny pores (below 3%) and a density above 3.11 g/cm³.

For a number of years, this SiC variant has been used as a standard shaft seal material. Pressure and temperature limits are slightly below those of WC/WC.

Q₁^P, porous, sintered, fine-grained SiC

A variant of the dense, sintered SiC. This SiC variant has large, circular, closed pores. The degree of porosity is 5 - 15% and the size of the pores 10 - 50 μm.

The density is around 2.7 - 3 g/cm³. The pressure and temperature limits exceed those of WC/WC.

Consequently, in warm water, the Q₁^P/Q₁^P face material pairing generates less noise than the WC/WC pairing. However, noise from porous SiC seals must be expected during the running-in wear period of 3 - 4 days.

Q₁^G, self-lubricating, sintered SiC

Several variants of SiC materials containing dry lubricants are available on the market. In this document, the designation Q₁^G applies to a SiC material which is suitable for use in distilled or demineralized water, as opposed to the above materials.

Pressure and temperature limits of Q₁^G/Q₁^G are similar to those of Q₁^P/Q₁^P.

The dry lubricants, i.e. graphite, reduce the friction in case of dry running, which is of decisive importance to the durability of a seal during dry running.

SiC/SiC features

The SiC/SiC material pairing has the following features:

- Very brittle material requiring careful handling.
- Extremely wear-resistant.
- Extremely good corrosion resistance. SiC (Q_1^S , Q_1^P and Q_1^G) hardly corrodes, irrespective of the pumped liquid type. However, an exception is water with very poor conductivity, such as demineralized water, which attacks the SiC variants Q_1^S and Q_1^P whereas Q_1^G is corrosion-resistant also in this liquid.
- In general, the material pairings have poor dry-running properties (like WC/WC); however, the Q_1^G/Q_1^G material withstands a limited period of dry running because of the graphite content of the material.

Carbon/tungsten carbide or carbon/silicon carbide

Seals with one carbon seal face have the following features:

- Brittle material requiring careful handling.
- Worn by liquids containing solid particles.
- Good corrosion resistance.
- Good dry-running properties (temporary dry running).
- The self-lubricating properties of carbon make the seal suitable for use even with poor lubricating conditions (high temperatures) without generating noise. However, such conditions will cause wear of the carbon seal face leading to reduced seal life. The wear depends on the pressure, temperature, liquid, diameter and seal design.
Low speeds reduce the lubrication between the seal faces; as a result, increased wear might have been expected. However, this is normally not the case because the distance that the seal faces have to move is reduced.
- Metal-impregnated carbon (A) offers limited corrosion resistance, but improved mechanical strength, heat conductivity and thus reduced wear.
- With reduced mechanical strength, but higher corrosion resistance, synthetic resin-impregnated carbon (B) covers a wide application field. Synthetic resin-impregnated carbon is approved for potable applications.
- The use of carbon/SiC for hot-water applications may cause heavy wear on the SiC, depending on the quality of the carbon and water.
This type of wear primarily applies to Q_1^S /carbon. The use of Q_1^P , Q_1^G or a carbon/WC pairing causes far less wear. Thus, carbon/WC, carbon/ Q_1^P or carbon/ Q_1^G are recommended for hot water systems.

Carbon/ceramic (aluminium oxide)

Good all-round seal for not too demanding applications. The seal has the following features:

- Brittle material requiring careful handling.
- Worn by liquids containing solid particles.
- Limited corrosion resistance, $5 < \text{pH} < 9$, depending on ceramic type.
- Relatively good dry-running properties. However, thermal cracks may occur in case of a sudden influx of water to a hot seal after a period of dry running or similar condition.
- The carbon of the seal offers properties very similar to the carbon/WC seal. However, compared to the carbon/WC seal, the pressure and temperature ranges are limited.

Tungsten carbide/hybrid

Combining the positive properties of the WC/WC and carbon/WC seal face combinations, the WC/hybrid pairing has the following features:

- Extremely wear-resistant.
- Resistant to rough handling.
- Certain dry-running properties (temporary dry running).
- Corrosion resistance equal to EN 1.4401, corresponding to the resistance of a CRN pump. In certain corrosive liquids and solvents, the resistance is restricted.
- Application limits as to pressure and temperature are similar to WC/WC due to the risk of seizure. However, exceeding the limits may damage the hybrid.

Some of the additives used in anti-freeze liquids on glycol basis may cause precipitation, especially at high temperatures. In such cases, WC/WC should be used, if possible.

Silicon carbide

The ceramic silicon carbide (SiC) has been manufactured for many years.

There are three main types of SiC:

- Reaction bonded and liquid phase sintered grades have limited corrosion resistance in alkaline water due to the content of free silicon.
- Converted carbon is produced from carbon graphite and can also be made as a thin SiC layer on the surface of the carbon.
- The most common SiC for seal rings are direct sintered silicon carbide.

Direct sintered SiC

The direct sintered SiC has a typical porosity below 2%, but also grades with pores have been developed. These pores are discrete, non-interconnected and dispersed in a controlled manner throughout the body of the material. The spherical pores act as fluid or lubricant reservoirs helping to promote the retention of a fluid film at the interface of sliding component surfaces. This pore-based lubrication mechanism allows porous SiC to outperform conventional reaction-bonded and sintered silicon carbides in hot water.

Extended sintering or adding different fillers can imply variations in these standard SiC grades. Fillers can be added to obtain better electric conductivity, more toughness or lower friction.

Carbon or graphite inclusions can be used as dry lubricant to reduce friction. Low friction of graphite can only be achieved with appropriate impurities because the intrinsic friction of graphite is high. For graphite to successfully act as a lubricant, the bonding between the SiC and the graphite as well as the size and amount of the graphite inclusions must be optimized. In a working seal the graphite must be smeared out in the seal face to reduce friction and it must be possible to remove some of the graphite from the inclusions.

Performance of seals with different SiC variants

Evaluation of materials for seal faces requires thorough testing at many different testing conditions.

SiC seal materials can be subjected to the following tests:

- Performance in hot water applications
- Dry running
- Water containing abrasive particles
- Water containing glycol
- Demineralized water
- Seizure test.

The tests are described in detail as from page 18.

During the last 15 years almost 50 different SiC grades have been tested at Grundfos and categorized in groups according to performance.

Q^S is a conventional dense sintered SiC with a porosity of less than 2%. This grade has poor performance in hot water and high dry friction.

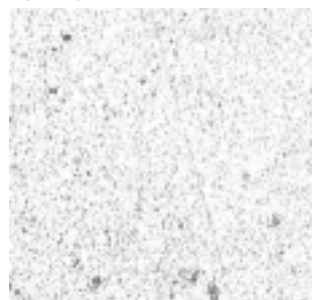

TM02 7726 3603

Fig. 20 Direct-sintered, dense SiC, Q_1^S

Q^P is a sintered SiC with discrete, non-interconnecting pores. The pores give better performance in hot water, but the dry friction is high. Graphite-containing SiC with poor dry running capability or poor performance in demineralized water are also categorized in this group.

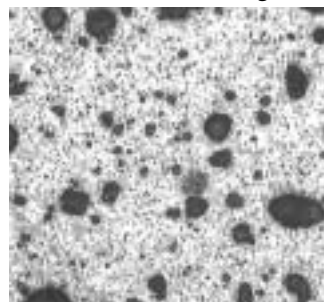

TM02 7727 3603

Fig. 21 Direct-sintered, porous SiC, Q_1^P

Q^G is a dense sintered SiC with bimodular grain size and pores of carbon/graphite or other low friction modifiers.

It has good performance in hot water and demineralized water, and has low dry friction.

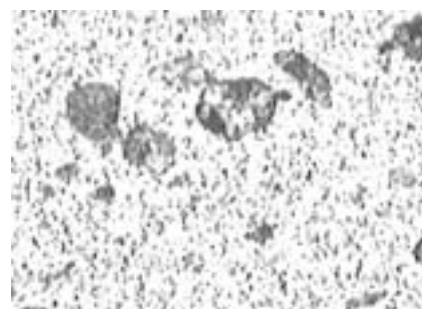

TM02 7728 3603

Fig. 22 Direct-sintered, porous SiC, Q_1^G

Performance in hot water

The lubrication of the seal faces in hot water is scarce due to the low viscosity of water at high temperatures and evaporation in the seal gap.

Limits of temperature and pressure ranges are based on tests where factors such as friction, torque and leakage are measured.

Above these limits noise from the seals may be expected and fatigue wear may occur.

The figure below shows the limits from the different SiC groups and tungsten carbide for a $\varnothing 16$ mm Grundfos type A seal at $3,000 \text{ min}^{-1}$. At lower speeds the limits are shifted towards lower temperatures.

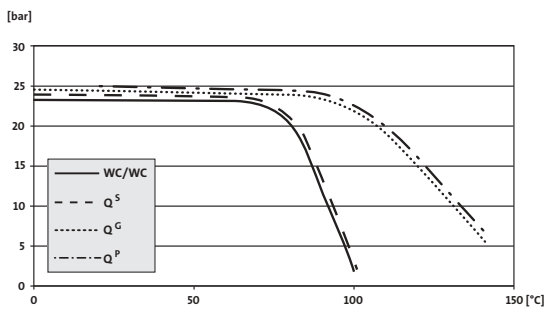

Fig. 23 Limits for stable friction of a seal

For information about the SiC variants (Q^S , Q^P and Q^G) see page 15.

The hot water tests are performed in tap water. Under these conditions the seal faces are exposed to very little wear in the stable region, whereas some wear might be expected above the limit for stable operation.

The figure below shows the wear rate as a function of temperature.

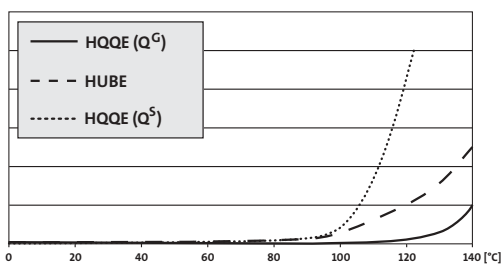

Fig. 24 Wear rate of seal faces

Dry running

Mechanical seals running completely dry can be destroyed within one minute if the friction between the seal faces is high. The heat dissipated in the seal face will raise the temperature of the seal to above $+200^\circ\text{C}$ and the rubber parts will burn off.

The friction of SiC against SiC depends of the fillers added to the SiC and the way these are bonded to the SiC matrix. Relative humidity affects the coefficient of friction for SiC materials even though this has little practical

effect on a mechanical seal because the temperature quickly rises above $+100^\circ\text{C}$ at which point humidity has no effect.

Temperatures measured on the stationary seat on selected dry running seals can be seen on figure 26.

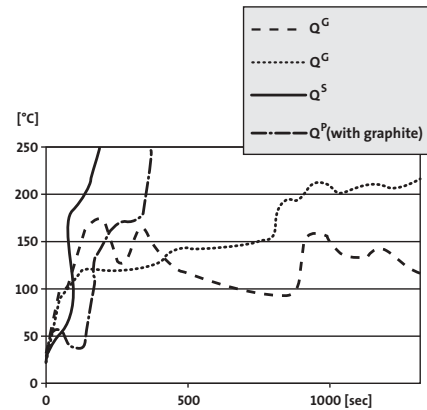

Fig. 25 Dry-running performance of seals

As will be seen on figure 26, $\text{SiC}^S/\text{SiC}^S$ and $\text{SiC}^P/\text{SiC}^P$ show poor dry-running performance, similar to WC/WC.

The two $\text{SiC}^G/\text{SiC}^G$ grades show better dry-running performance. The dry-running performance may vary slightly, even within the same grade of SiC^G .

Although it contains graphite, the SiC^P grade shown cannot be categorized as SiC^G , due to its poor dry-running properties.

Water containing abrasive particles

SiC is a hard material and is therefore less affected by abrasives. Wear on the seal faces caused by abrasives are rarely observed for seals with both faces in SiC. The seal gap in a mechanical seal is typically below 0.3 micron. Theoretically this means that only particles smaller than 0.3 micron can enter the seal face. In practice the edge of a seal face is not completely sharp. This means that particles measuring a few microns are able to enter the seal faces. Normally such small particles will only cause a polishing wear on a hard seal face. When one of the faces is a carbon ring, the edge of the seal face will wear and permit larger particles to enter the seal face.

Such larger particles can be trapped in the carbon seal face and cause wear on the counter face.

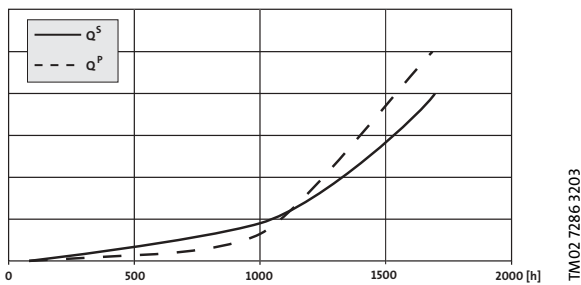

Fig. 26 Accumulative wear of seal rings running in 2,000 ppm sand

It is not recommended to use a porous SiC seal face against a carbon face in water containing a high level of dissolved solids.

Abrasive wear may be observed on seals with hard seal faces in corrosive liquids. Wear on SiC may occur in demineralised water due to corrosion in grain boundaries.

Wear on SiC faces may occur in hot water. It may look like abrasive wear because SiC grains are pulled out due to thermal fatigue of SiC. This type of wear is only seen above the pressure and temperature limit for stable friction.

Water containing glycol

Water containing glycol may cause problems with leaking seals. The problems often arise due to additives such as inhibitors, antioxidants, alkalines etc.

Some additives, e.g. silicates, may crystallize in the seal face as hard particles. Hard crystallites such as silicates or phosphates will cause wear on seals with one face in carbon.

Organic film binders, so-called inhibitors, adhere to all surfaces in contact with the liquid, including a major part of the seal face. Many inhibitors may build up sticky layers on the seal face resulting in leakage.

Seals with both seal faces of WC or SiC have better self-cleaning properties regarding deposits than seals with a carbon seal face.

A high closing force and a narrow width of the seal face reduce the risk of deposits building up. Comparisons of seal face pairings in water containing glycol with a high content of additives have been performed and results can be seen in the graph below.

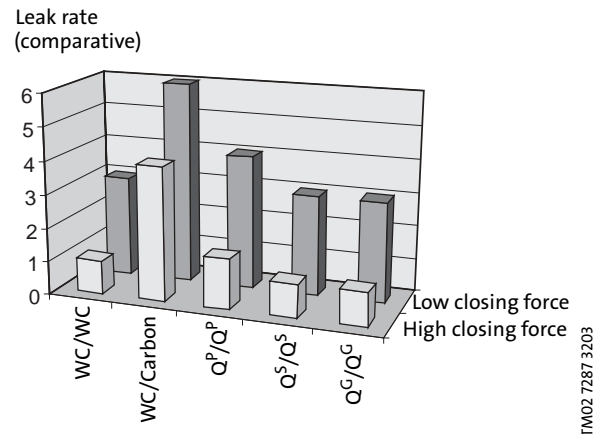

Fig. 27 Leakage of seals in water containing glycol

Surface roughness is an important factor for the leakage. A smooth surface finish is preferred. On the other hand a too smooth surface finish may cause problems in terms of seizure between the seal faces. Thus some roughness of the seal faces is required to prevent the seal rings from seizing up. Therefore seals have at least one lapped seal face.

After the shaft seal has been mounted, the leak rate will be high until the seal faces have become smooth.

As a result seals with one seal face in carbon often have low leakage in the running-in period because this period is shorter as compared to a seal with both seal faces in hard materials.

Seals with a high closing force have a shorter running-in period as a result of a thinner lubricating film.

Demineralised water

Pure water can be aggressive to many ceramics. Regarding sintered SiC, the grain boundaries containing sinter additives may be attacked in pure water.

Corrosion attacks are only observed on the seal face where high temperatures may be achieved where asperity contacts.

By controlling the sintering process it is possible to achieve SiC grades that are resistant to pure water.

Tests of seals in demineralised water at +40°C have been carried out for different SiC grades. The result of standard sintered SiC grades can be seen on the graph below.

For grades not sensitive to demineralised water no failure has been observed during 11,000 hours of testing. Only grades resistant in demineralised water can be categorized in group Q^G.

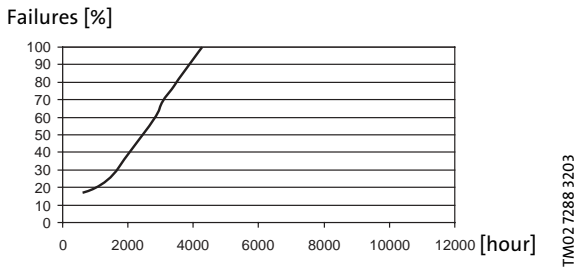

Fig. 28 Failure of SiC seals in demineralised water

Seizure of seal faces caused by storing

Very smooth and flat seal faces will easily adhere to each other. In extreme situations the adhesion becomes so strong that the shaft on the motor of the pump cannot rotate.

There are different mechanisms acting on the adhesion between the seal faces.

Physical adhesion

Vacuum may occur when two flat and smooth surfaces are pressed tightly together.

The force created by the vacuum is axial, meaning that the force needed to separate the two surfaces has to be large whereas the shear force needed to rotate the surfaces is lower. The size of the shear force at start-up is the same as the force needed for a very low rotational speed. The coefficient of friction at low rotational speed for different surface pairings can be seen on the graph below.

Start friction in water

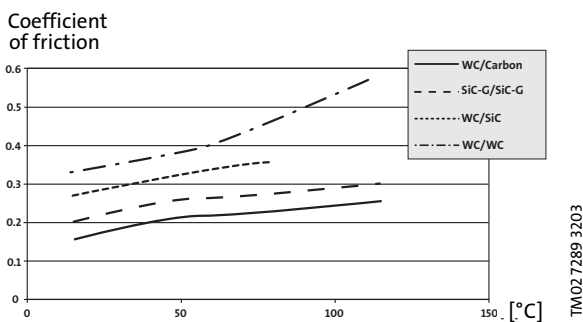

Fig. 29 Start friction in water

Chemical adhesion of surfaces

All surfaces subjected to the atmosphere have an oxide layer. The equilibrium of the oxide layer may change when the surface is in close contact with another surface or when it is exposed to the pumped liquid. This change in equilibrium may involve chemical bindings to oxides from other surfaces. The more inert the oxide layer is to the surroundings, the weaker will the bindings to the counter surface be. If the liquid is aggressive to the seal face material, the seal faces may corrode together and create immensely high adhesion forces.

To prevent such adhesion mechanisms, highly inert dissimilar materials of the seal faces are preferred.

Chemical adhesion involving adhesive agents

If the pumped liquid contains ions that may precipitate on the seal face, these precipitations may act as glue between the seal faces.

This adhesion mechanism may occur in hard water and can be reduced by using one seal face as a carbon ring. Also hard materials containing solid lubricants will reduce adhesion because the dry lubricant will be smeared out as a thin layer on the seal face, providing low shear forces.

Conclusion

The sensitivity to abrasive particles is low when using hard materials in both seal rings such as SiC against SiC.

Friction of SiC against SiC in hot water are reduced by the porosities in the seal face material. Generally, the resistivity to corrosion of sintered SiC is good except in pure water, but with SiC containing long grains also resistance against pure water can be obtained.

Incorporating small pockets filled with solid lubricants can reduce dry friction of SiC.

Mechanical seals with improved SiC grades Q^G are thus able to handle many different applications, thereby increasing the reliability of the pump.

Secondary seals

The choice of materials for secondary seals, i.e. rubber components such as O-rings and bellows, is just as important as the choice of seal face combinations. Both are essential to the functioning of the mechanical shaft seal. The Grundfos seals are intended to cover a wide application field with few materials.

The sections below indicate main material properties as regards temperature and resistance to principal liquid groups. In case of doubt and where special liquids are involved, please contact Grundfos.

NBR

Widely used for all-round applications, NBR (nitrile) rubber covers a wide range of liquids at relatively low temperatures (below +100°C).

- Good mechanical properties at high and low temperatures
- Heat resistant up to +100°C for short periods up to +120°C, depending on the ambient environment
- Resistant to water up to +80°C
- Resistant to diesel oil, various mineral oils, grease and vegetable oils
- Resistant to weak acids and alkalis
- Not resistant to polar solvents (alcohols, ketones and esters)
- Not resistant to ozone and weather.

EPDM

Especially suitable for use in water and aqueous solutions, EPDM rubber is non-resistant to mineral oils.

- Good mechanical properties at low temperatures
- Heat resistant up to +150°C
- Resistant to water up to +140°C
- Resistant to polar solvents (alcohols, ketones and esters)
- Resistant to ozone and weather
- Resistant to glycol
- Partly resistant to vegetable oils at low temperatures
- Not resistant to mineral oils.

FKM

FKM rubber covers a very wide range of liquids and temperatures.

- Poor mechanical properties at low temperatures
- Heat resistant up to +200°C
- Resistant to water up to +90°C
- Resistant to acids and saline solutions
- Resistant to mineral oils and vegetable oils
- Resistant to most solvents (toluene, petrol, trichloroethylene, etc.)
- Resistant to ozone and weather
- Not resistant to certain polar solvents (e.g. alcohols, ketones and esters)
- Not resistant to alkaline liquids at high temperatures.

FFKM

FFKM (perfluoroelastomer) is chemically resistant to a wide range of liquids. FFKM rubber corresponds to PTFE, but offers considerably better mechanical properties.

- Good mechanical properties
- Resistant to water up to +150°C
- Especially suitable for use in chemical processing plants, in the production of dyes, paints, varnishes, solvents, nitric acid, etc.
- Resistant to ozone and weather
- Not entirely resistant to amines and strongly alkaline liquids at high temperatures.

FXM

FXM (fluorinated copolymer) is particularly suitable for extremely high temperatures and pressures as well as for use in acid liquids and gasses within oil and gas extraction (in boreholes, on land and at sea). Its resistance to chemicals and high temperatures has been considerably improved as compared to fluorized rubber, with excellent resistance to hot water and steam.

- Elastic seal material
- Temperature range: -10°C to +275°C, for short periods up to +300°C
- Excellent hot water and steam resistance
- Available in material resistant to sudden decompression.

Consisting of a modified structure of tetrafluoroethylene (TFE) and propylene copolymers, FXM is widely used within

- the chemical and petrochemical industry
- the aviation and space industry
- mechanical engineering
- refineries.

List of pumped liquids

The table below shows the resistance of the secondary seal rubber materials to low and high temperatures and to a selection of pumped liquids.

Factors	NBR	EPDM	FKM	FFKM	FXM
Low temperatures (temp. < 0°C)	+	+	-	-	-
High temperatures (temp. > +90°C)★	-	+	-	+	+
Acids	±	±	±	+	±
Alkalis	+	+	-	+	+
Glycols	+	+		+	+
Oils and fuels	±	-	+	+	±
Solvents	-	-	±	+	-

★ Based on water.

Legend

Symbol	Meaning
+	Suitable
±	Suitable under certain conditions
-	Not suitable

A number of typical pumped liquids are listed below.

The table below shows the resistance of the secondary seal rubber materials to low and high temperatures and to a selection of pumped liquids.

Pumped liquid	Chemical formula	Description
	Sulphuric acid	H ₂ SO ₄ Inorganic acid
	Hydrochloric acid	HCl Inorganic acid
	Phosphoric acid	H ₃ PO ₄ Inorganic acid
Acids (pH < 7)	Nitric acid	HNO ₃ Inorganic acid
	Chromic acid	CrO ₃ Inorganic acid
	Acetic acid	CH ₃ COOH Organic acid
	Formic acid	HCOOH Organic acid
	Sodium hydroxide	NaOH
	Potassium hydroxide	KOH
Alkalis (pH > 7)	Calcium hydroxide	CaOH
	Ammonium hydroxide	NH ₄ OH
	Propylene glycol	CH ₂ OHCHOHCH ₃
Coolants	Ethylene glycol	C ₂ H ₄ (OH) ₂
	Glycerine	CH ₂ OHCH ₂ OH
	Petrol	Mineral oil
Fuels and oils	Diesel oil	Mineral oil
	Olive oil	Vegetable oil
	Xylene	C ₆ H ₄ (CH ₃) ₂
Solvents	Trichloroethylene	C ₂ HCl ₃
	Benzene	C ₆ H ₆

Types of shaft seals

The following pages give a short description of some of Grundfos' mechanical shaft seal types, including their application profiles.

Due to the wear on carbon seal faces, the description of carbon shaft seal types includes a table indicating service intervals.

Grundfos type A

Grundfos type A seal is defined as an O-ring seal with fixed seal driver.

Description/features

- Strong seal drivers ensure torque transmission even under extreme operating conditions.
- Risk of fretting (wear corrosion) in corrosive liquids. Fretting occurs when an O-ring wears the protective oxide film of a stainless steel shaft.
- Risk of deposits around the O-ring as well as seizure of the O-ring in liquids with a large content of lime or sludge. Often observed as leakage in connection with changes in operating conditions.

As standard available in tungsten carbide/tungsten carbide (WC/WC) with EPDM or FKM O-rings.

Some sizes are available in silicon carbide/silicon carbide (SiC/SiC).

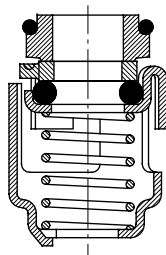

TM00 2581 4593

Fig. 30 Type A seal

Application profile

The type A seal has a WC/WC application profile.

Type A with WC/WC seal faces

There is no relation between the indication of suitability and the pressure/temperature diagrams, but together they form the application profile.

Suitability

	Suitable	Suitable under certain conditions	Not suitable
Alkaline liquids	Yes	No	No
Acid liquids	No	Yes	No
Dry running	No	No	Yes
Solid particles in liquid	Yes	No	No
Precipitating/lime-containing liquids	No	Yes	No
Anti-freeze liquids	No	Yes	No

Pressure/temperature diagrams

The pressure/temperature diagrams are based on clean water.

The figures in the following table refer to the pressure/temperature diagrams.

Pos.	Range
1	Optimum duty range
2	Risk of periodical noise in connection with start-up and variations in pressure and temperature
3	Risk of periodical noise
4	Reduced life

Note: Noise occurs especially at low speeds.

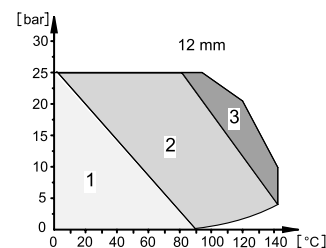
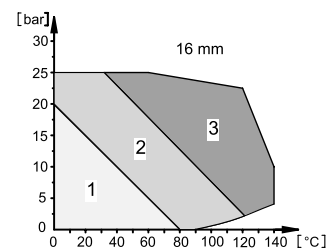
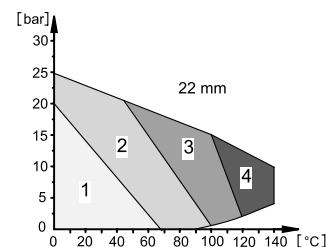

TM00 2588 4593

Fig. 31 Pressure/temperature diagrams

Grundfos type B

Grundfos type B seal is defined as a bellows seal with rubber bellows.

Description/features

- Suitable for lime- and sludge-containing liquids where there is a risk of deposits and seizure.
- Resists fretting (wear corrosion) which occurs when an O-ring wears the protective oxide film of a stainless steel shaft.

As standard available in WC/carbon, SiC/SiC and SiC/carbon with EPDM or FKM bellows.

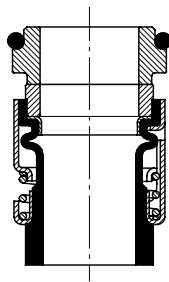

TM00 2582 3097

Fig. 32 Type B seal

Application profiles

The type B seal has the following application profiles:

- WC/carbon
- SiC/SiC
- SiC/carbon.

Type B with WC/carbon seal faces

There is no relation between the indication of suitability and the pressure/temperature diagrams, but together they form the application profile.

Suitability

	Suitable	Suitable under certain conditions	Not suitable
Alkaline liquids	■	■	
Acid liquids		■	■
Dry running	■	■	
Solid particles in liquid		■	■
Precipitating/lime-containing liquids		■	■
Anti-freeze liquids			■

Pressure/temperature diagrams

The pressure/temperature diagrams are based on clean water.

The figures in the following table refer to the pressure/temperature diagrams.

Pos.	Recommended service intervals [operating hours] before wear-out
1	14,000 - 20,000
2	8,000 - 15,000
3	4,000 - 8,000

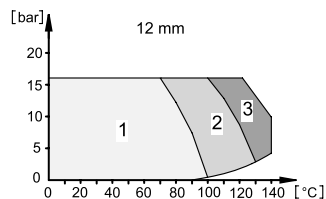
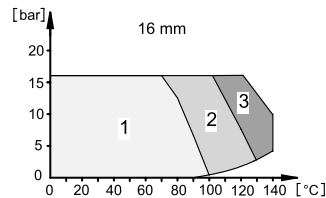
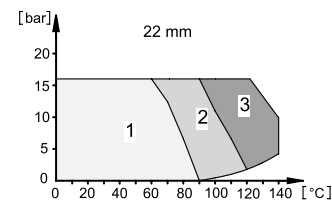

TM02 4275 0402

Fig. 33 Pressure/temperature diagrams

Type B with SiC/SiC seal faces (Q_1^G/Q_1^G)

There is no relation between the indication of suitability and the pressure/temperature diagrams, but together they form the application profile.

Suitability

	Suitable	Suitable under certain conditions	Not suitable
Alkaline liquids	Yes	No	No
Acid liquids	Yes	No	No
Dry running	No	Yes	No
Solid particles in liquid	No	Yes	No
Precipitating/lime-containing liquids	No	Yes	No
Anti-freeze liquids	No	Yes	No

Pressure/temperature diagrams

The pressure/temperature diagrams are based on clean water.

The figures in the following table refer to the pressure/temperature diagrams.

Pos.	Range
1	Optimum duty range
2	Risk of periodical noise in connection with start-up and variations in pressure and temperature

Note: Noise occurs especially at low speeds.

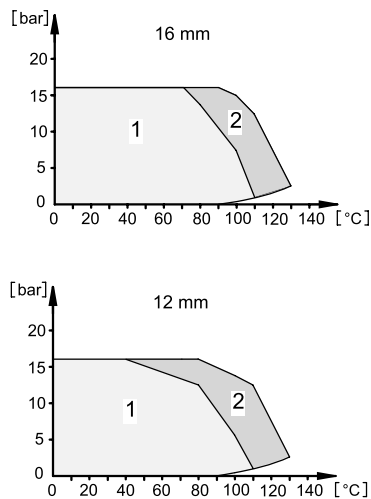

Fig. 34 Pressure/temperature diagrams

TM00 2590 3097

Type B with SiC/carbon seal faces

There is no relation between the indication of suitability and the pressure/temperature diagrams, but together they form the application profile.

Suitability

	Suitable	Suitable under certain conditions	Not suitable
Alkaline liquids	Yes	No	No
Acid liquids	Yes	No	No
Dry running	No	Yes	No
Solid particles in liquid	No	Yes	No
Precipitating/lime-containing liquids	No	Yes	No
Anti-freeze liquids	No	Yes	No

Pressure/temperature diagrams

The pressure/temperature diagrams are based on clean water.

The figures in the following table refer to the pressure/temperature diagrams.

Pos.	Recommended service intervals [operating hours] before wear-out
1	14,000 - 20,000
2	8,000 - 15,000
3	4,000 - 8,000

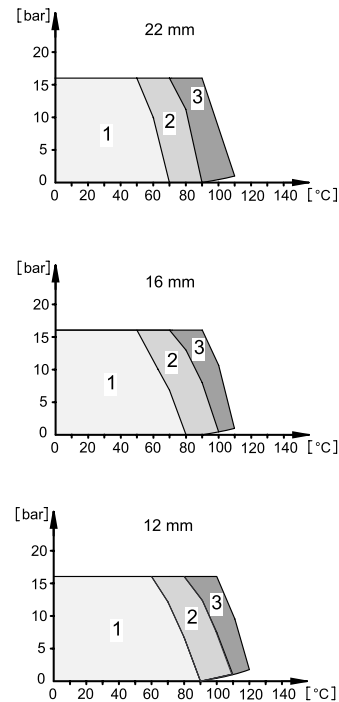

Fig. 35 Pressure/temperature diagrams

TM00 2589 3097

Grundfos type C

Grundfos type C seal is defined as a O-ring seal with a spring as seal driver.

Description/features

- Simple seal for low pressure and temperature ranges.

As standard available in ceramic/carbon with NBR, EPDM or FKM O-ring.

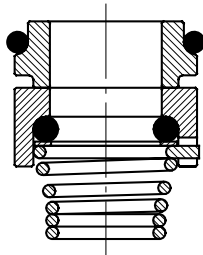

TM00 2583 4593

Fig. 36 Type C seal

Application profile

The type C seal has a ceramic/carbon application profile.

Type C with ceramic/carbon seal faces

There is no relation between the indication of suitability and the pressure/temperature diagrams, but together they form the application profile.

Suitability

	Suitable	Suitable under certain conditions	Not suitable
Alkaline liquids		■	
Acid liquids	■		
Dry running	■		
Solid particles in liquid			■
Precipitating/lime-containing liquids		■	
Anti-freeze liquids			■

Pressure/temperature diagrams

The pressure/temperature diagrams are based on clean water.

The figures in the following table refer to the pressure/temperature diagrams.

Pos.	Recommended service intervals [operating hours] before wear-out
1	14,000 - 20,000
2	8,000 - 15,000

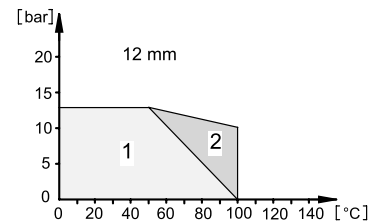

TM00 2592 3097

Fig. 37 Pressure/temperature diagrams

Grundfos type D

Grundfos type D seal is defined as a balanced O-ring seal.

Description/features

- The design of the shaft seal makes it an ideal solution when pumping solid-containing and high-viscosity liquids.
- The shaft seal is independent of the direction of rotation.
- Suitable for cylindrical shafts.

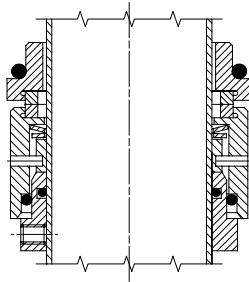

TM02 7094 2603

Fig. 38 Type D seal

Application profile

The type D seal has the following application profiles:

- Carbon/SiC
- SiC/SiC.

Type D with carbon/SiC seal faces

Suitability

	Suitable	Suitable under certain conditions	Not suitable
Alkaline liquids	■		
Acid liquids	■		
Dry running	■		
Solid particles in liquid			■
Precipitating/lime-containing liquids		■	
Anti-freeze liquids			■

The type D seal with carbon/silicon carbide seal faces are suited for operation at temperatures from 0°C to +140°C and for an operating pressure of up to 25 bar.

Type D with SiC/SiC seal faces

There is no relation between the indication of suitability and the pressure/temperature diagrams, but together they form the application profile.

Suitability

	Suitable	Suitable under certain conditions	Not suitable
Alkaline liquids		■	
Acid liquids		■	
Dry running			■
Solid particles in liquid		■	
Precipitating/lime-containing liquids		■	
Anti-freeze liquids		■	

The type D seal with SiC/SiC seal faces are suited for operation at temperatures from -20°C to +90°C and at a operating pressure of up to 16 bar.

Grundfos type E

Grundfos type E seal is defined as a O-ring seal, type A, cartridge type.

Description/features

- Strong seal drivers transmit the torque even under extreme operating conditions.
- Risk of fretting (wear corrosion) in corrosive liquids. Fretting occurs when an O-ring wears the protective oxide film of a stainless steel shaft.
- Risk of deposits around the O-ring as well as seizure of the O-ring in liquids with a large content of lime or sludge.
- As standard available in WC/carbon, WC/WC or in WC/hybrid with EPDM or FKM O-rings.
- Can be replaced without dismantling the pump part. In addition, the shaft seal of pumps with motor sizes above 7.5 kW can be replaced without removing the motor.
- Only available for pump types CR 32 to CR 90 and CRN 32 to CRN 90.

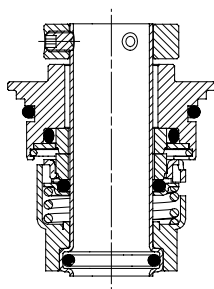

TM01.3065 3398

Fig. 39 Type E seal

Application profiles

The type E seal has the following application profiles:

- WC/hybrid
- WC/WC
- WC/carbon.

Type E with WC/hybrid seal faces

There is no relation between the indication of suitability and the pressure/temperature diagrams, but together they form the application profile.

Suitability

	Suitable	Suitable under certain conditions	Not suitable
Alkaline liquids		■	
Acid liquids			
Dry running		■	
Solid particles in liquid		■	
Precipitating/lime-containing liquids		■	
Anti-freeze liquids			■

Pressure/temperature diagrams

The pressure/temperature diagrams are based on clean water.

The figures in the following table refer to the pressure/temperature diagrams.

Pos.	Range
1	Optimum duty range
2	Risk of periodical noise in connection with start-up and variations in pressure and temperature

Note: Noise occurs especially at low speeds.

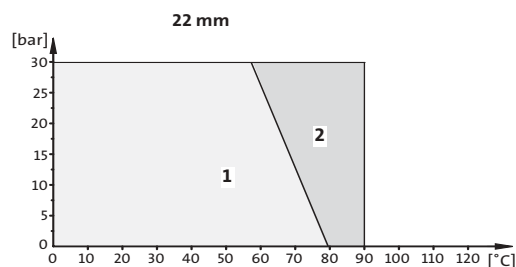

TM01.8343 0100

Fig. 40 Pressure/temperature diagrams

Type E with WC/WC seal faces

There is no relation between the indication of suitability and the pressure/temperature diagrams, but together they form the application profile.

Suitability

	Suitable	Suitable under certain conditions	Not suitable
Alkaline liquids	Yes	No	No
Acid liquids	No	Yes	No
Dry running	No	No	Yes
Solid particles in liquid	Yes	No	No
Precipitating/lime-containing liquids	No	Yes	No
Anti-freeze liquids	Yes	No	No

Pressure/temperature diagrams

The pressure/temperature diagrams are based on clean water. At temperatures below freezing point, the diagram is based on a mixture of water and glycol.

The figures in the following table refer to the pressure/temperature diagrams.

Pos.	Range
1	Optimum duty range
2	Risk of periodical noise in connection with start-up and variations in pressure and temperature

Note: Noise occurs especially at low speeds.

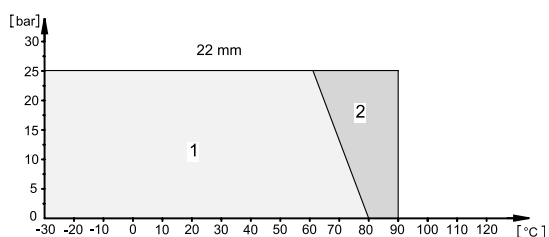

TM01 1416 3398

Fig. 41 Pressure/temperature diagrams

Type E with WC/carbon seal faces

There is no relation between the indication of suitability and the pressure/temperature diagrams, but together they form the application profile.

Suitability

	Suitable	Suitable under certain conditions	Not suitable
Alkaline liquids	Yes	No	No
Acid liquids	No	Yes	No
Dry running	No	No	Yes
Solid particles in liquid	Yes	No	No
Precipitating/lime-containing liquids	No	Yes	No
Anti-freeze liquids	Yes	No	No

Pressure/temperature diagram

The pressure/temperature diagrams are based on clean water.

The figures in the following table refer to the pressure/temperature diagrams.

Pos.	Recommended service intervals [operating hours] before wear-out
1	14,000 - 20,000
2	8,000 - 15,000
3	4,000 - 8,000

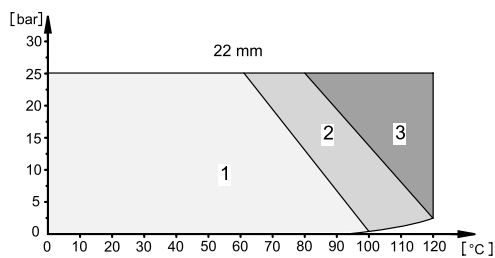

TM01 1418 4497

Fig. 42 Pressure/temperature diagrams

Grundfos type G

Grundfos type G seal is defined as an unbalanced O-ring seal with a rubber bellows.

Description/features

- Especially suitable for anti-freeze liquids or liquids containing large quantities of solid or precipitated particles.
- Suitable for lime- and sludge-containing liquids where there is a risk of deposits and seizure.
- Resists fretting (wear corrosion) which occurs when an O-ring wears the protective oxide film of a stainless steel shaft.
- The shaft seal is independent of the direction of rotation.

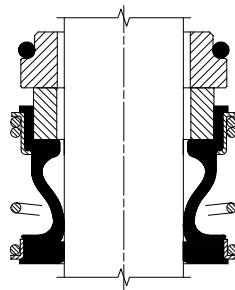

TM02 7099 2603

Fig. 43 Type G seal

Application profiles

The type G seal has the following application profile:

- SiC/SiC.

Suitability

	Suitable	Suitable under certain conditions	Not suitable
Alkaline liquids	■	■	
Acid liquids		■	
Dry running			■
Solid particles in liquid	■	■	
Precipitating/lime-containing liquids		■	
Anti-freeze liquids	■		

Pressure/temperature diagram

The pressure/temperature diagram is based on clean water. At temperatures below freezing point the diagrams are based on a mixture of water and glycol.

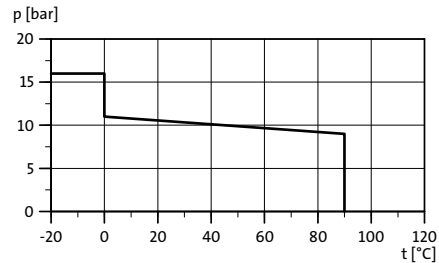

TM02 7282 3103

Fig. 44 Pressure/temperature diagram

Grundfos type H

Grundfos type H seal is defined as an O-ring seal of the cartridge type.

Description/features

- Thanks to the balanced seal design, this robust seal is suitable for pressures up to 30 bar.
- Can be replaced without dismantling the pump part.
- Easy to replace during service.
- Risk of fretting (wear corrosion) in corrosive liquids. Fretting occurs when an O-ring wears the protective oxide film of a stainless steel shaft. As the seal is designed as a cartridge seal with a sleeve on the shaft, fretting damages the sleeve and not the shaft. This enables replacement of the seal without having to make an entire renovation of the pump.
- Risk of deposits around the O-ring as well as seizure of the O-ring in liquids with a large content of lime or sludge.

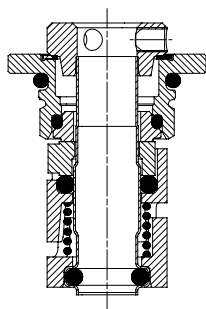

TM02 7100 2603

Fig. 45 Type H seal

Application profiles

The type H seal has the following application profiles:

- SiC/SiC
- SiC/carbon
- WC/carbon
- WC/WC.

Type H for $\varnothing 12$, $\varnothing 16$ and $\varnothing 22$ mm shaft with SiC/SiC (Q_1^G/Q_1^G) seal faces

- The seal is suitable for use in CR/CRI/CRN pumps.
- The strong seal carriers contribute considerably to the cooling of the seal faces in case of dry running. This makes the seal capable of withstanding several minutes of dry running, despite the seal face material pairing.
- Suitable for lime- and sludge-containing liquids where there is a risk of deposits and seizure.

There is no relation between the indication of suitability and the pressure/temperature diagrams, but together they form the application profile.

Suitability

	Suitable	Suitable under certain conditions	Not suitable
Alkaline liquids	Yes	No	No
Acid liquids	No	Yes	No
Dry running	No	Yes	No
Solid particles in liquid	No	No	Yes
Precipitating/lime-containing liquids	No	Yes	No
Anti-freeze liquids	No	Yes	No

Pressure/temperature diagrams

The pressure/temperature diagrams are based on clean water.

The figures in the following table refer to the pressure/temperature diagrams.

Pos.	Range
1	Optimum duty range
2	Risk of periodical noise in connection with start-up and variations in pressure and temperature
3	Risk of periodical noise and reduced lifetime.

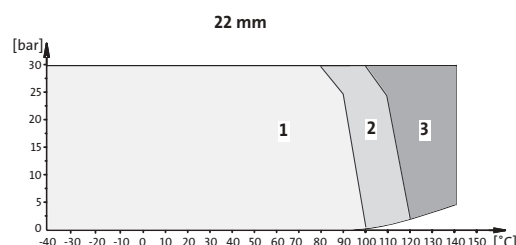
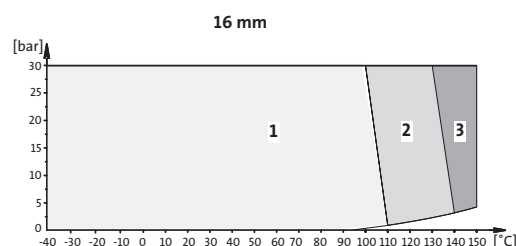
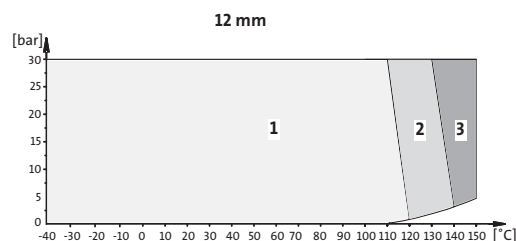

TM02 8448 0204

Fig. 46 Pressure/temperature diagrams

Type H for $\varnothing 12$, $\varnothing 16$ and $\varnothing 22$ mm shaft with SiC/carbon seal faces

Suitable for use in CR/CRI/CRN pumps, the seal is recommended for use in very hot water (above 100°C). Can be replaced without dismantling the pump part.

There is no relation between the indication of suitability and the pressure/temperature diagrams, but together they form the application profile.

Suitability

	Suitable	Suitable under certain conditions	Not suitable
Alkaline liquids	Yes	No	No
Acid liquids	No	Yes	No
Dry running	No	Yes	No
Solid particles in liquid	No	Yes	No
Precipitating/lime-containing liquids	No	No	Yes
Anti-freeze liquids	No	No	Yes

Pressure/temperature diagrams

The pressure/temperature diagrams are based on clean water. At temperatures below freezing point, the diagrams are based on a mixture of water and glycol.

The figures in the following table refer to the pressure/temperature diagrams.

Pos.	Recommended service intervals [operating hours] before wear-out
1	14,000 - 20,000
2	8,000 - 14,000
3	4,000 - 8,000

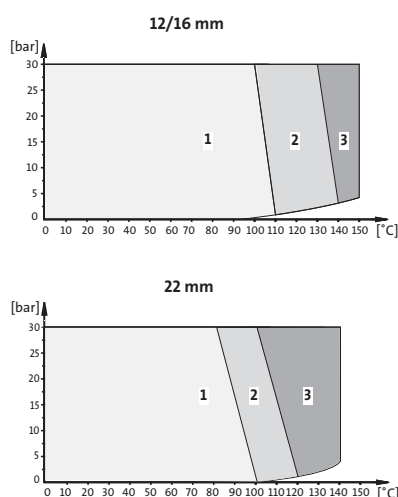

Fig. 47 Pressure/temperature diagrams

TMO2.8445 0204

Type H for $\varnothing 12$, $\varnothing 16$ and $\varnothing 22$ mm shaft with WC/carbon seal faces

Suitable for use in CR/CRI/CRN pumps, the seal is recommended for use in very hot water (above 100°C). Can be replaced without dismantling the pump part.

There is no relation between the indication of suitability and the pressure/temperature diagrams, but together they form the application profile.

Suitability

	Suitable	Suitable under certain conditions	Not suitable
Alkaline liquids	Yes	No	No
Acid liquids	No	Yes	No
Dry running	No	Yes	No
Solid particles in liquid	No	Yes	No
Precipitating/lime-containing liquids	No	No	Yes
Anti-freeze liquids	No	No	Yes

Pressure/temperature diagrams

The pressure/temperature diagrams are based on clean water. At temperatures below freezing point, the diagrams are based on a mixture of water and glycol.

The figures in the following table refer to the pressure/temperature diagrams.

Pos.	Recommended service intervals [operating hours] before wear-out
1	14,000 - 20,000
2	8,000 - 14,000
3	4,000 - 8,000

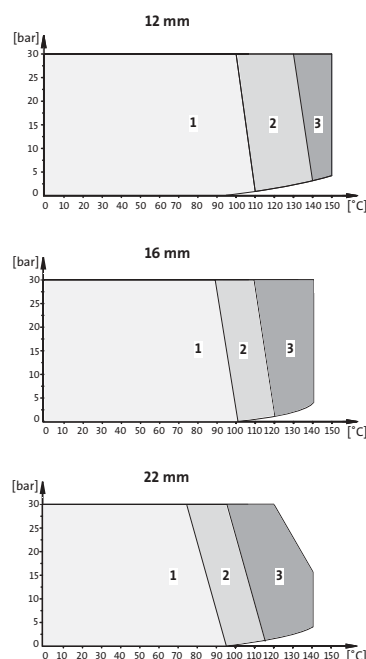

Fig. 48 Pressure/temperature diagrams

TMO2.8446 0204

Type H for $\varnothing 12$, $\varnothing 16$ and $\varnothing 22$ mm shaft with WC/WC seal faces

- The seal is suitable for use in CR/CR1/CRN pumps for many applications, except for very hot water (above $+100^{\circ}\text{C}$). Can be replaced without dismantling the pump part.
- The strong seal carriers contribute considerably to the cooling of the seal faces in case of dry running. This makes the seal capable of withstanding several minutes of dry running, despite the seal face material pairing.

There is no relation between the indication of suitability and the pressure/temperature diagrams, but together they form the application profile.

Suitability

	Suitable	Suitable under certain conditions	Not suitable
Alkaline liquids	■	■	
Acid liquids		■	■
Dry running		■	■
Solid particles in liquid	■		
Precipitating/lime-containing liquids		■	■
Anti-freeze liquids		■	■

Pressure/temperature diagrams

The pressure/temperature diagrams are based on clean water. The figures in the following table refer to the pressure/temperature diagrams.

Pos.	Range
1	Optimum duty range
2	Risk of periodical noise in connection with start-up and variations in pressure and temperature
3	Risk of periodical noise

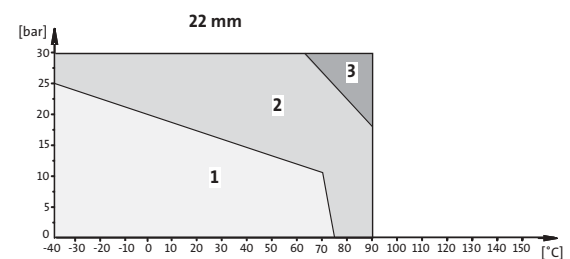
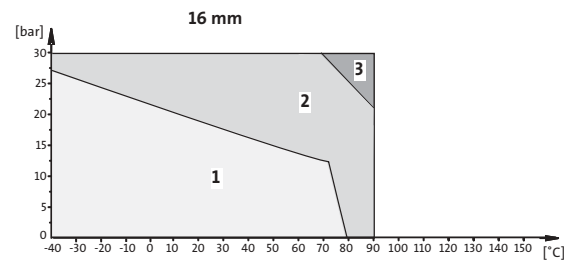
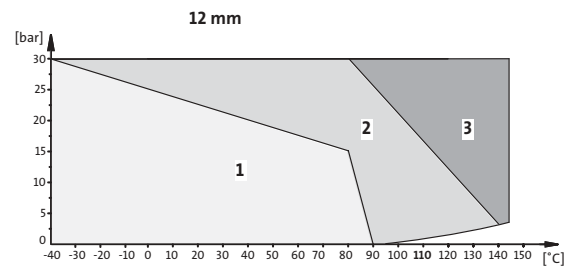

TM02 8447 02.04

Fig. 49 Pressure/temperature diagrams

Grundfos type K

Grundfos type K seal is defined as a metal bellows seal (type M, cartridge type).

Description/features

- Especially suitable for liquids containing large quantities of precipitated particles.
- The seal is suitable for temperatures above +100°C.
- Can be replaced without dismantling the pump part. In addition, the shaft seal of pumps with motor sizes above 7.5 kW can be replaced without removing the motor.
- The seal has a long life compared with other seal types due to the balancing ratio.
- Suitable for lime- and sludge-containing liquids where there is a risk of deposits and seizure.

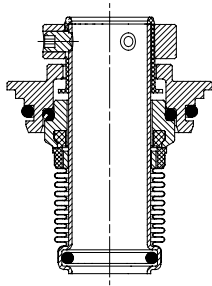

TM02.4279 0402

Fig. 50 Type K seal

Application profiles

The type K seal has the following application profiles:

- WC/carbon
- WC/hybrid
- WC/WC.

Type K with WC/carbon seal faces

There is no relation between the indication of suitability and the pressure/temperature diagrams, but together they form the application profile.

Suitability

	Suitable	Suitable under certain conditions	Not suitable
Alkaline liquids	Yes	No	No
Acid liquids	No	Yes	No
Dry running	No	Yes	No
Solid particles in liquid	No	No	Yes
Precipitating/lime-containing liquids	Yes	No	No
Anti-freeze liquids	No	No	Yes

Pressure/temperature diagrams

The pressure/temperature diagrams are based on clean water.

The figures in the following table refer to the pressure/temperature diagrams.

Pos.	Recommended service intervals [operating hours] before wear-out
1	14,000 - 20,000
2	8,000 - 14,000
3	4,000 - 8,000

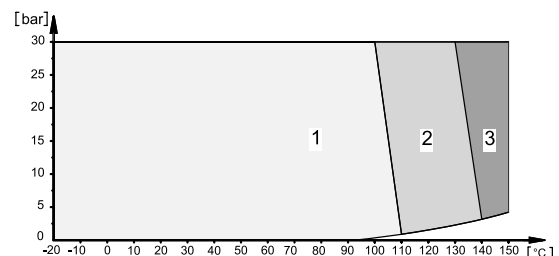

TM02.4300 0402

Fig. 51 Pressure/temperature diagrams

Type K with WC/hybrid seal faces

There is no relation between the indication of suitability and the pressure/temperature diagrams, but together they form the application profile.

Suitability

	Suitable	Suitable under certain conditions	Not suitable
Alkaline liquids		█	
Acid liquids		█	
Dry running		█	
Solid particles in liquid		█	
Precipitating/lime-containing liquids		█	
Anti-freeze liquids			█

Pressure/temperature diagrams

The pressure/temperature diagrams are based on clean water.

The figures in the following table refer to the pressure/temperature diagrams.

Pos.	Range
1	Optimum duty range
2	Risk of periodical noise in connection with start-up and variations in pressure and temperature

Note: Noise occurs especially at low speeds.

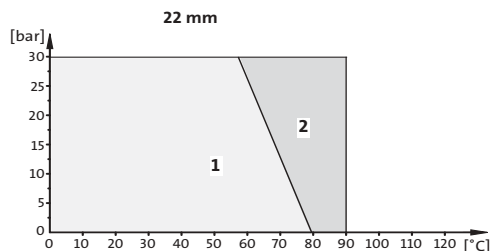

TM01 8343 0204

Fig. 52 Pressure/temperature diagrams

Type K with WC/WC seal faces

There is no relation between the indication of suitability and the pressure/temperature diagrams, but together they form the application profile.

Suitability

	Suitable	Suitable under certain conditions	Not suitable
Alkaline liquids	█		
Acid liquids	█	█	
Dry running			█
Solid particles in liquid	█		
Precipitating/lime-containing liquids		█	
Anti-freeze liquids	█		

Pressure/temperature diagrams

The pressure/temperature diagrams are based on clean water. At temperatures below freezing point, the diagrams are based on a mixture of water and glycol.

The figures in the following table refer to the pressure/temperature diagrams.

Pos.	Range
1	Optimum duty range
2	Risk of periodical noise in connection with start-up and variations in pressure and temperature

Note: Noise occurs especially at low speeds.

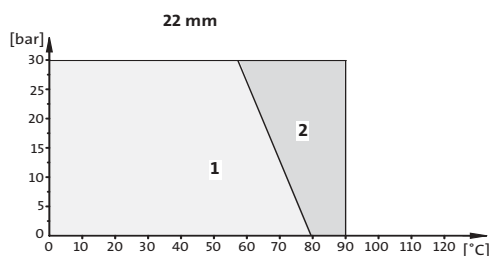

TM01 8343 0204

Fig. 53 Pressure/temperature diagrams

Grundfos type R

Grundfos type K seal is defined as an O-ring seal, type A, with fixed seal driver and reduced seal face.

Description/features

- Especially suitable for anti-freeze liquids or liquids containing large quantities of solid or precipitated particles.
- Strong seal drivers ensure torque transmission even under extreme operating conditions.
- Lapped seal faces with a flat, rough surface prevent seizure, possibly causing a slight leakage during the running-in wear period (10 - 30 days).
- Risk of fretting (wear corrosion) in corrosive liquids. Fretting occurs when an O-ring wears the protective oxide film of a stainless steel shaft.
- As standard available in $\varnothing 12$, $\varnothing 16$ and $\varnothing 22$ in WC/WC with EPDM or FKM O-rings.

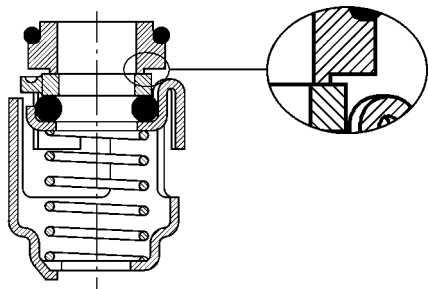

TM015046 1499

Fig. 54 Type R seal

Application profile

The type R seal has a WC/WC application profile.

Type R with WC/WC seal faces

There is no relation between the indication of suitability and the pressure/temperature diagrams, but together they form the application profile.

Suitability

	Suitable	Suitable under certain conditions	Not suitable
Alkaline liquids	■	■	
Acid liquids		■	
Dry running			■
Solid particles in liquid	■	■	
Precipitating/lime-containing liquids		■	
Anti-freeze liquids	■	■	

Pressure/temperature diagrams

The pressure/temperature diagrams are based on clean water. At temperatures below freezing point, the diagrams are based on a mixture of water and glycol.

The figures in the following table refer to the pressure/temperature diagrams.

Pos.	Range
1	Optimum duty range
2	Risk of periodical noise in connection with start-up and variations in pressure and temperature

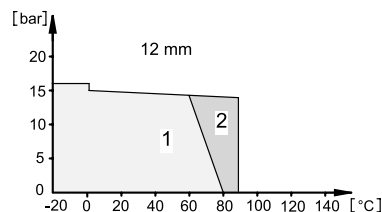
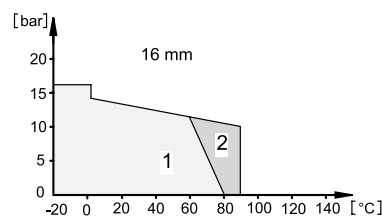
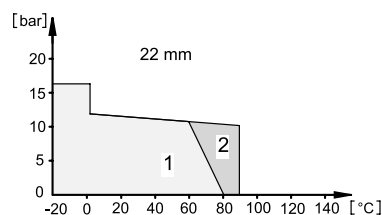

TM017406 4599

Fig. 55 Pressure/temperature diagrams

Seal arrangements

Grundfos offers the following types of double seals:

- Double seal mounted back-to-back, Grundfos type O
- Double seal mounted in tandem, Grundfos type P
- Cartex-DE seal, Grundfos type Q.

Double seal (back-to-back)

Grundfos type O seal is defined as two double seals mounted in a back-to-back arrangement.

Description

This type of double seal consists of two shaft seals mounted back-to-back in a separate seal chamber.

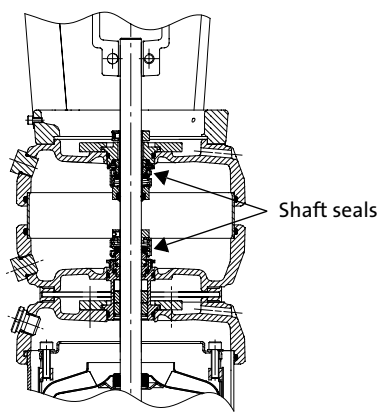

Fig. 56 Back-to-back seal arrangement in a CR pump

The pressure in the seal chamber **must** be higher than the pump pressure. The pressure in the seal chamber can be generated by

- a pressure intensifier when the operating pressure is above 16 bar
- a separate pump, e.g. a dosing pump, when the operating pressure is less or equal to 16 bar or
- an existing, separate pressure source. Many applications incorporate pressurized systems.

The back-to-back arrangement with pressurized seal chamber prevents the pumped liquid from leaking through the shaft seal to the environment.

Applications

Double seals mounted back-to-back are recommended for use with toxic, aggressive or explosive liquids. The back-to-back arrangement protects the surrounding environment and the people working in the vicinity of the pump.

This type of shaft seal is the optimum solution for handling abrasive or sticky liquids which would either wear out, damage or block a mechanical shaft seal.

The double seal mounted back-to-back is used in

- paint industries
- distilling industries
- petrochemical industries.

Double seal (tandem)

Grundfos type P seal is defined as two double seals mounted in a tandem arrangement.

Description

This type of double seal consists of two shaft seals mounted in tandem in a separate seal chamber. Only Grundfos cartridge shaft seals can be used.

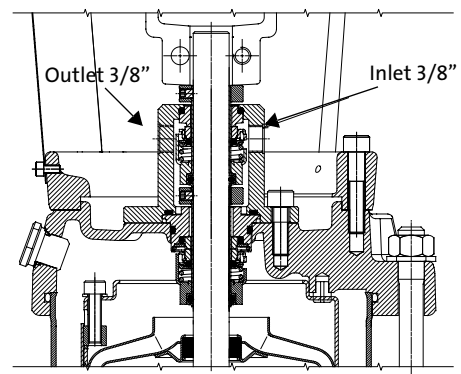

Fig. 57 Tandem seal arrangement in a CR pump

If the primary seal is leaking in a CR pump, the pumped liquid will be flushed away by the flushing liquid.

The flushing liquid pressure **must always** be lower than the pumped liquid pressure.

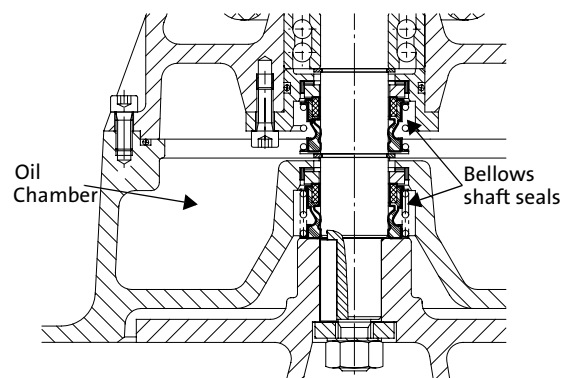

Fig. 58 Tandem seal arrangement in an AP pump

Grundfos AP sewage pumps have either

- a combination of a mechanical bellows seal and a lip seal between the motor and the pump or
- two mechanical bellows seals mounted on either side of the oil chamber.

The tandem arrangement prevents sewage from entering and destroying the motor.

Applications

Double seals mounted in tandem are recommended for use with crystallising, hardening or sticky liquids in

- pharmaceutical industries (i.e. production of dextran),
- negative pressure deaeration systems (vacuum)
- industries handling potentially hardening oil products
- industries producing caustic soda (sodium hydroxide - NaOH)
- industries producing hydrated lime (calcium hydroxide $(Ca(OH)_2)$)
- Sewage.

Cartex-DE shaft seals

Grundfos type Q seal is a Cartex-DE double seal.

Description

The Cartex-DE seal is a double-pressure-balanced shaft seal preassembled in one unit for use in centrifugal pumps.

The Cartex-DE seal is available as a single-seal and as a double seal, depending on the application.

In a two-seal arrangement, the Cartex-DE double seal can be mounted

- in tandem (Grundfos type P) or
- back-to-back (Grundfos type O).

For further information about tandem or back-to-back seal arrangements, see page 37.

The Cartex-DE seal is independent of the direction of rotation.

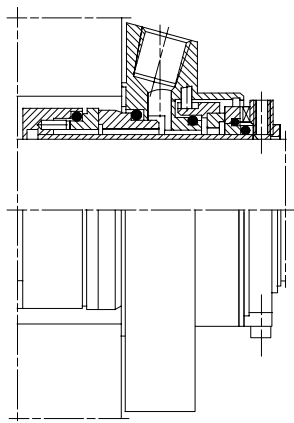
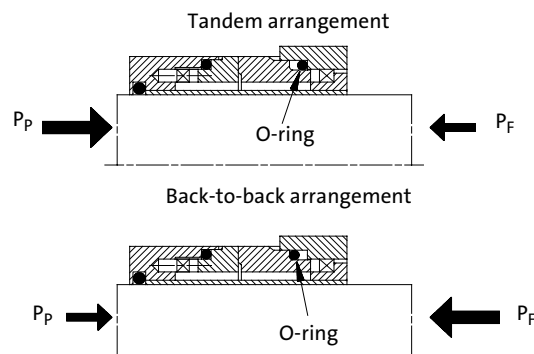

Fig. 59 Cartex-DE seal

TM02 7109 2603



TM02 7449 3503

Fig. 60 Cartex-DE shaft seal in tandem - and back-to-back arrangement

As will be seen above, the two arrangements affect the functionality of the shaft seal in different ways.

In the tandem arrangement the pumped liquid pressure (P_p) is **higher** than the flushing liquid pressure (P_f). This pressure distribution displaces the shaft axially to the right allowing pumped liquid to be pressed into the gap between the rotating and the stationary parts. As a result of the displacement, the O-ring moves to the right and seals against the flushing liquid coming from the lower right side of the chamber.

In the back-to-back arrangement the pumped liquid pressure (P_p) is **lower** than the flushing liquid pressure (P_f).

The pressure distribution displaces the shaft axially to the left allowing flushing liquid to be pressed into the gap between the rotating and stationary parts. As the shaft moves left, the O-ring follows and seals against the pumped liquid coming from the upper left side of the chamber.

During operation the coolant is pumped by the pump rotating shaft from the tank through the shaft seal. The circulating coolant prevents overheating of the shaft seal.

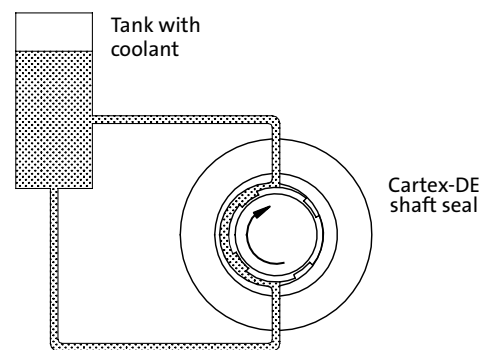

TM02 7114 2703

Fig. 61 Cooling of a Cartex-DE seal

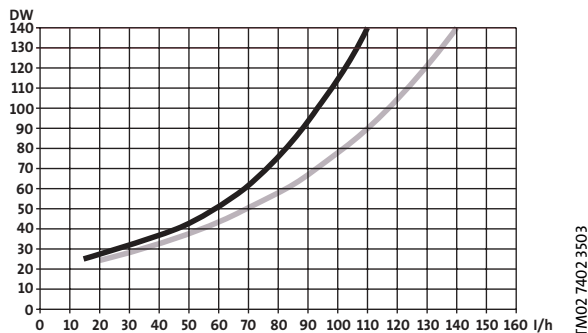

Fig. 62 Circulation volume of Cartex-DE

Application profiles

The Cartex-DE shaft seal has the following application profiles:

- Carbon graphite/SiC
- SiC/SiC.

Pressure/velocity diagram

The diagram of the pressure in relation to the velocity of the seal faces is based on clean water.

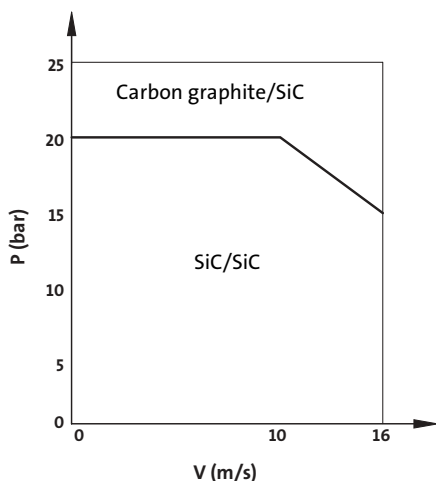

Fig. 63 Pressure/velocity of seal face diagram

Air-cooled top (for high temperatures)



Fig. 64 Photo of a CR pump with an air-cooled top assembly

General information

The unique Grundfos air-cooled top shaft seal solution is recommended for applications involving high temperatures from +120°C to +180°C.

The following air-cooled top solutions are available:

- Pump fitted with EPDM rubber parts: +120 to +150°C
- Pump fitted with FKM rubber parts: +120 to +180°C.

Applications

- Boiler feeding
- Temperature control, e.g. in moulding processes
- Circulation of transmission oils.

Pump range

The air-cooled top is available for the following Grundfos pumps:

+120 to +150°C and +120 to +180°C

Pump type	CR 1	CR 3	CR 5	CR 10	CR 15	CR 20	CR 32	CR 45	CR 64	CR 90
CR	-	-	-	-	-	-	•	•	•	•
CRI	•	•	•	•	•	•	-	-	-	-
CRN	•	•	•	•	•	•	•	•	•	•

Technical description

The air-cooled top separates the seal chamber from the pump by an air-cooled chamber, generating an insulating effect similar to that of a thermos.

Through the narrow passage between the pump and the air-cooled top, a small quantity of the pumped liquid recirculates by natural circulation.

Temperatures above +120°C normally result in a substantial reduction of seal life due to poor lubrication of the seal faces.

As the temperature in the seal chamber does not exceed +120°C during operation, a standard Grundfos shaft seal can be used.

The Grundfos air-cooled top does **not** require any external cooling.

An automatic air vent is required to vent the pump seal chamber.

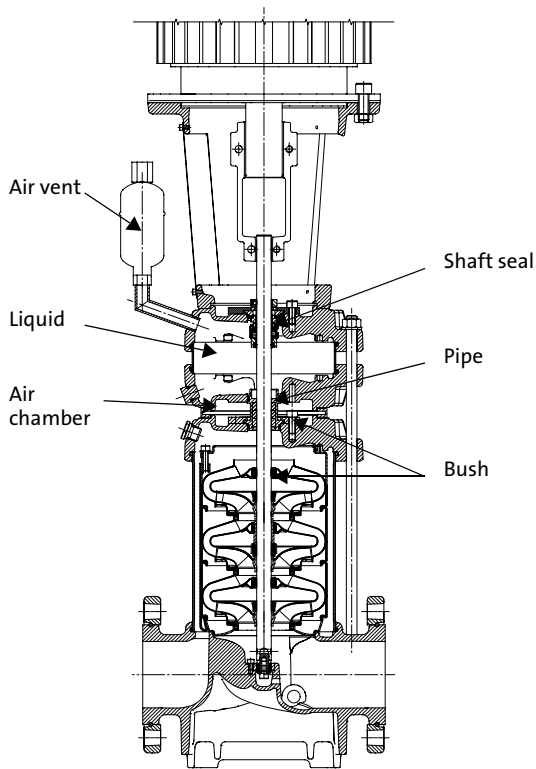

TM01 4785 0899

Fig. 65 Drawing of a CR pump with an air-cooled top assembly

Comparing seal types

The comparison is based on a seal design for maximum 16 bar without considering seal face and secondary seal materials, as they have been dealt with separately.

The asterisks indicate degree of suitability with respect to the parameters stated, five asterisks being the optimum suitability.

Comparison parameters	Type A	Type B	Type C	Type E	Type G	Type H	Type K	Type R
Anti-freeze liquid	★★★★	★★★	★★★	★★★★	★★★★★	★★★★	★★★★★	★★★★★
Precipitation	★★★	★★★★	★★★	★★★	★★★★	★★★	★★★★★	★★★★
Above +100°C	★★	★★★	★★	★★★	*	★★★★	★★★★★	*
Assembly time	★★	★★★	★★★	★★★★★	★★	★★★★★	★★★★★	★★
Robustness against assembly faults	★★★	★★★	★★★	★★★★	★★★	★★★★	★★★★	★★★
Start/stop	★★★	★★★	★★★	★★★	★★★	★★★★	★★★★	★★★
High pressure	★★★	★★	*	★★★	*	★★★★★	★★★★★	*
Breakdown of rubber parts	★★★	★★	★★★	★★★	★★★	★★★	★★★★	★★★
Seal driver strength (cementing)	★★★★★	★★★	★★★	★★★★★	★★★★★	★★★★★	★★★★★	★★★★★
Long life	★★★★	★★★	★★★	★★★★	★★★	★★★★	★★★★★	★★★
Dry running with tungsten carbide/ tungsten carbide material pairing	★★	★★★	★★	★★	★★	★★★★	*	★★
Robustness against rough handling	★★★★	★★★	★★★	★★★	★★★★	★★★★	★★★	★★★

Selection of the most suitable shaft seal

The list of pumped liquids in a data booklet often indicates several suitable shaft seals for the pumping of the same liquid.

As the properties of the suitable shaft seals often differ, the purpose of this section is to give an example of how to select the most suitable shaft seal.

Example

The following data is assumed:

Application: Shaft seal fitted in boiler feed pump, type CR.

Operating pressure: 26 [bar]

Operating temperature: +115 [°C]

In the CR, CRI, CRN, CRE, CRIE, CRNE data booklet only one shaft seal, HQQE, is recommended for pumping boiler water.

On the other hand the HQQE shaft seal is not the only shaft seal available for this pump and application.

As will appear from the description of the various shaft seal types in this data booklet, the following seal types are suitable:

- HQQE (recommended shaft seal)
- HQQV
- HUBE
- BUBE
- AUUE.

Comparing maximum operating pressures

Comparing the maximum operating pressure range of the above shaft seal types, it appears that

- the HQQE shaft seal is suitable because the operating pressure of the boiler feed pump does not exceed the 30 bar maximum operating pressure of the shaft seal, see "Grundfos type H" on page 31.
- the HQQV shaft seal is suitable because the operating pressure of the boiler feed pump does not exceed the 30 bar maximum operating pressure of the shaft seal, see "Grundfos type H" on page 31.
- the HUBE shaft seal is suitable because the operating pressure of the boiler feed pump does not exceed the 30 bar maximum operating pressure of the shaft seal, see "Grundfos type H" on page 31.
- the BUBE shaft seal is **not** suitable because the maximum operating pressure of the shaft seal is 16 bar, see "Grundfos type B" on page 24.
- The AUUE shaft seal is **not** suitable because the maximum operating pressure of the shaft seal is 25 bar, see "Grundfos type A" on page 23.

This leads to the conclusion that among the shaft seals indicated, only the type H shaft seals, HUBE, HQQE and HQQV, are suitable.

Comparing maximum operating temperatures

As the HUBE, HQQE and HQQV seals have different secondary seal materials, the maximum operating temperature of the seals may differ.

Position 4 of the shaft seal configuration, e.g. HUBE, shows the secondary seal material. For further information see page 6.

Shaft seals with an EPDM secondary seal resist water temperatures up to +140°C, see "EPDM" on page 21.

Shaft seals with an FKM secondary seal resist water temperatures up to +90°C, see "FKM" on page 21.

This leaves only two suitable shaft seals, HUBE and HQQE.

Resistance to abrasive particles

The high pumped liquid temperature above +60°C may cause lime to precipitate in the pumped liquid resulting in scale formation.

Deposits on the seal faces may result in wear and reduced seal life.

According to the Grundfos type designation, the HUBE seal face material combination is tungsten carbide/carbon, see page 5.

This tungsten carbide/carbon material combination offers low-noise operation. However, the deposits between the seal faces will lead to reduced seal life.

The HQQE seal face material combination is silicon carbide/silicon carbide (SiC/SiC), see page 5.

Under the operating conditions in this example, the SiC/SiC material combination offers long life as compared to the HUBE seal. However, the shaft seal will emit more noise on account of the materials used.

Finally, the shaft seal that best matches the requirements of the particular application is to be selected:

As a boiler feed pump is usually not located in noise-critical environments, an HQQE shaft seal is preferred on account of its long life. If an HQQE shaft seal is selected, a higher noise level must be accepted.

Lists of pumped liquids

The following tables indicate the suitability of the individual shaft seals in various pumped liquids. The suitability only applies to the mechanical shaft seal and is not related to pumps in general.

The suitability of the individual seal combinations is based on the information on temperature, concentration, etc. given in the tables. Changes in these conditions will affect the suitability of the seal.

Intended as a guide, the lists of pumped liquids are based on the latest knowledge and experience.

As the lists of pumped liquids do not state the toxicity class of the individual liquids, it does not clearly appear from the lists whether the seal is appropriate for the task in question in order to avoid health hazards (corrosion, poisoning, etc.).

Acids

Legend

- ++ = Best solution
- + = Suitable
- ± = Suitable under certain conditions
- = Not suitable

Liquid	Shaft seal (EN 12756)										
	Rotating face: Stationary seat: Secondary seal: Spring: Other parts:	Q	Q	B	B	B	B	U	U	B	B
Acetic acid CH ₃ COOH	Max. temp. [°C]	20		20				20		20	
	Max. conc. [%]	5		5				5		5	
	Suitability	++	-	+	-	-	-	±	-	±	
	Comments										
Acetic anhydride (CH ₃ CO) ₂ O	Max. temp. [°C]	20		20				20		20	
	Max. conc. [%]	3		3				2		2	
	Suitability	++	-	+	-	-	-	±	-	±	-
	Comments	Aqueous solution (forms acetic acid).									
Benzoic acid C ₆ H ₅ COOH	Max. temp. [°C]		80		80				80		80
	Max. conc. [%]		5		5				5		5
	Suitability	-	++	-	+	-	-	-	+	-	+
	Comments										
Chromic acid CrO ₃	Max. temp. [°C]	20	20	20	20						
	Max. conc. [%]	20	20	20	20						
	Suitability	++	++	+	+	-	-	-	-	-	-
	Comments										
Citric acid HOC(COOH)(CH ₂ COOH) ₂	Max. temp. [°C]	80	80	80	80			40	40	40	40
	Max. conc. [%]	50	50	50	50			5	5	5	5
	Suitability	++	++	+	+	-	-	++	++	+	+
	Comments										
Formic acid HCOOH	Max. temp. [°C]	20		20				20		20	
	Max. conc. [%]	50		50				5		5	
	Suitability	++	-	+	-	-	-	+	-	+	-
	Comments										
Hydrochloric acid HCl	Max. temp. [°C]	15	15	15	15						
	Max. conc. [%]	<0.1	<0.1	<0.1	<0.1						
	Suitability	±	±	±	±	-	-	-	-	-	-
	Comments	Risk of pitting on stainless steel parts.									
Lactic acid CH ₃ CHOHCOOH	Max. temp. [°C]	20	20	20	20			20	20	20	20
	Max. conc. [%]	50	50	50	50			20	20	20	20
	Suitability	++	++	+	+	-	-	+	+	+	+
	Comments										
Nitric acid HNO ₃	Max. temp. [°C]	20	20	20	20						
	Max. conc. [%]	30	5	30	5						
	Suitability	++	+	++	+	-	-	-	-	-	-
	Comments										
Oxalic acid (COOH) ₂	Max. temp. [°C]	20	20	20	20			20	20	20	20
	Max. conc. [%]	15	15	15	15			5	5	5	5
	Suitability	++	++	+	+	-	-	±	±	±	±
	Comments										
Phosphoric acid H ₃ PO ₄	Max. temp. [°C]	60	60	60	60			50	50	50	50
	Max. conc. [%]	60	85	60	85			15	15	15	15
	Suitability	+	++	+	+	-	-	±	±	±	±
	Comments	Shaft seal with flush in concentrations above 50%.									

(Continued on the next page)

Acids, continued

Legend

- ++ = Best solution
- + = Suitable
- ± = Suitable under certain conditions
- = Not suitable

Liquid	Shaft seal (EN 12756)										
	Rotating face: Stationary seat: Secondary seal: Spring: Other parts:	Q	Q	B	B	B	B	U	U	B	B
Salicylic acid C ₆ H ₄ (OH)COOH	Max. temp. [°C]	80	80	80	80			80	80	80	80
	Max. conc. [%]	5	5	5	5			5	5	5	5
	Suitability	++	+	+	+	-	-	+	+	+	+
	Comments	Shaft seal with flush may be a good choice due to low solubility.									
Sulphamic acid NH ₂ SO ₃ H	Max. temp. [°C]		20		20						
	Max. conc. [%]		5		5						
	Suitability	-	++	-	+	-	-	-	-	-	-
	Comments										
Sulphuric acid H ₂ SO ₄	Max. temp. [°C]	20	20	20	20						
	Max. conc. [%]	5	5	5	5						
	Suitability	+	+	+	+	-	-	-	-	-	-
	Comments										
Sulphurous acid H ₂ SO ₃	Max. temp. [°C]	60		60				20		20	
	Max. conc. [%]	6		6				2		2	
	Suitability	+	-	+	-	-	-	±	-	±	-
	Comments										

Alkalis

Legend

- ++ = Best solution
- + = Suitable
- ± = Suitable under certain conditions
- = Not suitable

Liquid	Shaft seal (EN 12756)										
	Rotating face:	Q	Q	B	B	B	B	U	U	B	B
Stationary seat:	Q	Q	Q	Q	V	V	U	U	U	U	
Secondary seal:	E	V	E	V	E	V	E	V	E	V	
Spring:	G	G	G	G	G	G	G	G	G	G	
Other parts:	G	G	G	G	G	G	G	G	G	G	
Alkaline degreasing agent	Max. temp. [°C]	80		60				80		60	
	Max. conc. [%]	25		10				25		10	
	Suitability	++	-	+	-	-	-	++	-	+	-
	Comments	Shaft seal with flush/double shaft seal may be required; EPDM not applicable, if degreasing bath contains residue of oil.									
Ammonia NH ₃	Max. temp. [°C]	20		20				20		20	
	Max. conc. [%]	100		100				100		100	
	Suitability	±	-	++	-			±	-	++	-
	Comments	Shaft seal with flush/double shaft seal recommended; attacks copper alloys.									
Ammonium hydroxide (ammonia water) NH ₄ OH	Max. temp. [°C]	90		120				90		120	
	Max. conc. [%]	28		28				28		28	
	Suitability	++	-	++	-	-	-	++	-	++	-
	Comments	Shaft seal with flush/double shaft seal recommended; attacks copper alloys.									
Calcium hydroxide CaOH	Max. temp. [°C]	80	80					80	80		
	Max. conc. [%]	Saturated solution	Saturated solution					Saturated solution	Saturated solution		
	Suitability	++	+	-	-	-	-	++	+	-	-
	Comments	Saturation point at 0.18% at +20°C; shaft seal with flush/double shaft seal recommended for supersaturated solutions.									
Potassium hydroxide KOH	Max. temp. [°C]	60	20					60	20		
	Max. conc. [%]	30	5					30	5		
	Suitability	++	+	-	-	-	-	++	+	-	-
	Comments	Shaft seal with flush/double shaft seal recommended for concentrations above 25% due to crystal formation.									
Sodium hydroxide (caustic soda/soda lye) NaOH	Max. temp. [°C]	60	20					50	20		
	Max. conc. [%]	50	50					40	25		
	Suitability	++	±	-	-	-	-	++	±	-	-
	Comments	Shaft seal with flush/double shaft seal recommended for concentrations above 25% due to crystal formation (caustic soda lye).									

Salts

Legend

- ++ = Best solution
- + = Suitable
- ± = Suitable under certain conditions
- = Not suitable

Liquid	Shaft seal (EN 12756)										
	Rotating face:	Q	Q	B	B	B	B	U	U	B	B
	Stationary seat:	Q	Q	Q	Q	V	V	U	U	U	U
	Secondary seal:	E	V	E	V	E	V	E	V	E	V
	Spring:	G	G	G	G	G	G	G	G	G	G
Other parts:	G	G	G	G	G	G	G	G	G	G	
Ammonium bicarbonate NH ₄	Max. temp. [°C]	60		60		60		60		60	
	Max. conc. [%]	20		20		20		20		20	
	Suitability	++	-	+	-	+	-	++	-	+	-
	Comments	Decomposes in hot water.									
Ammonium chloride (sal ammoniac) NH ₄ Cl	Max. temp. [°C]	25	25	25	25			20	20	20	20
	Max. conc. [%]	10	10	10	10			5	5	5	5
	Suitability	++	++	+	+	-	-	+	+	+	+
	Comments	Shaft seal with flush/double shaft seal recommended; risk of pitting on stainless steel parts.									
Ammonium sulphate (NH ₄) ₂ SO ₄	Max. temp. [°C]	50		50				40		40	
	Max. conc. [%]	10		10				10		10	
	Suitability	++	-	+	-	-	-	++	-	+	-
	Comments										
Calcium acetate Ca(CH ₃ COO) ₂	Max. temp. [°C]	80						80			
	Max. conc. [%]	30						30			
	Suitability	++	-	-	-	-	-	++	-	-	-
	Comments	Used as corrosion inhibitor.									
Copper (II) sulphate CuSO ₄	Max. temp. [°C]	80	80					20	20		
	Max. conc. [%]	30	30					30	30		
	Suitability	++	++	-	-	-	-	+	+	-	-
	Comments										
Fixing salt	Max. temp. [°C]	80	80	80	80			80	80	80	80
	Max. conc. [%]	20	20	20	20			20	20	20	20
	Suitability	++	++	±	±	-	-	+	+	±	±
	Comments										
Magnesium sulphate MgSO ₄	Max. temp. [°C]	80	80					20	20		
	Max. conc. [%]	25	25					25	25		
	Suitability	++	++	-	-	-	-	+	+	-	-
	Comments										
Potassium permanganate KMnO ₄	Max. temp. [°C]	90	20	90	20						
	Max. conc. [%]	10	1	10	1						
	Suitability	++	±	+	±	-	-	-	-	-	-
	Comments										
Sodium bicarbonate NaHCO ₃	Max. temp. [°C]	50	50	50	50	50	50	50	50	50	50
	Max. conc. [%]	10	10	10	10	10	10	10	10	10	10
	Suitability	++	+	+	+	+	+	++	+	+	+
	Comments	Baking powder; decomposes in hot water.									
Sodium carbonate Na ₂ CO ₃	Max. temp. [°C]	80	60	80	60	80	60	80	60	80	60
	Max. conc. [%]	20	20	20	20	20	20	20	20	20	20
	Suitability	++	+	+	+	+	+	++	+	+	+
	Comments										
Sodium nitrate NaNO ₃	Max. temp. [°C]	80	80	80	80	80	80	80	80	80	80
	Max. conc. [%]	40	40	40	40	40	40	40	40	40	40
	Suitability	++	++	+	+	+	+	++	++	+	+
	Comments										

(Continued on the next page)

Salts, continued

Legend

- ++ = Best solution
- + = Suitable
- ± = Suitable under certain conditions
- = Not suitable

Liquid	Shaft seal (EN 12756)										
	Rotating face: Stationary seat: Secondary seal: Spring: Other parts:	Q	Q	B	B	B	U	U	B	B	
		Q	Q	Q	Q	V	V	U	U	U	U
		E	V	E	V	E	V	E	V	E	V
		G	G	G	G	G	G	G	G	G	G
		G	G	G	G	G	G	G	G	G	G
Sodium nitrite NaNO ₂	Max. temp. [°C]	90	90	90	90	90	90	90	90	90	90
	Max. conc. [%]	30	30	30	30	30	30	30	30	30	30
	Suitability	++	++	+	+	+	+	++	++	+	+
	Comments										
Sodium phosphate Na ₃ PO ₄	Max. temp. [°C]	80	80					80	80		
	Max. conc. [%]	20	20					20	20		
	Suitability	++	+	–	–	–	–	++	+	–	–
	Comments	Shaft seal with flush/double shaft seal may be required.									
Sodium sulphate Na ₂ SO ₄	Max. temp. [°C]	80	80	80	80			80	80	80	80
	Max. conc. [%]	30	30	30	30			30	30	30	30
	Suitability	++	++	+	+	–	–	++	++	+	+
	Comments										
Sodium sulphite Na ₂ SO ₃	Max. temp. [°C]	80	80	80	80	80	80	80	80	80	80
	Max. conc. [%]	20	20	20	20	20	20	20	20	20	20
	Suitability	++	++	+	+	+	+	++	++	+	+
	Comments										

Water

Legend

- ++ = Best solution
- + = Suitable
- ± = Suitable under certain conditions
- = Not suitable

Liquid	Shaft seal (EN 12756)										
	Rotating face: Stationary seat: Secondary seal: Spring: Other parts:	Q	Q	B	B	B	B	U	U	B	B
Boiler feed water	Max. temp. [°C]	120★		140	80	90	80			140	80
	Max. conc. [%]										
	Suitability	++	-	+	±	+	+	-	-	+	+
	Comments	★ Seal face needs to be SiC ^G .									
Calcareous water	Max. temp. [°C]	90	80					90	80		
	Max. conc. [%]										
	Suitability	++	+	-	-	-	-	++	+	-	-
	Comments										
Chlorine-containing water (unsalted)	Max. temp. [°C]	40	40	40	40	40	40	40	40	40	40
	Max. conc. [%]										
	Suitability	++	++	++	++	++	++	++	++	++	++
	Comments	Max. 5 ppm free chlorine (Cl ₂); swimming baths and chlorinated potable water.									
Demineralized water (desalinated)	Max. temp. [°C]	90	80	140	80	90	80	90	80	140	80
	Max. conc. [%]										
	Suitability	++★	-	±	±	+	+	+	+	++	+
	Comments	★ Seal face needs to be SiC ^G .									
Domestic hot water	Max. temp. [°C]	120★	80	140	80	90	80	90	80	140	80
	Max. conc. [%]										
	Suitability	++	+	++	+	+	+	+	+	++	+
	Comments	Risk of lime precipitation at temperatures above +60°C. ★ Seal face needs to be SiC ^G .									
Oil- containing water	Max. temp. [°C]		80		80		80		80		80
	Max. conc. [%]										
	Suitability	-	+	-	++	-	+	-	+	-	++
	Comments										
Ozone- containing water	Max. temp. [°C]	40	40	40	40	40	40	40	40	40	40
	Max. conc. [%]										
	Suitability	++	++	++	++	++	++	++	++	++	++
	Comments	1 ppm ozone (O ₃); soluble in water at 0°C.									
Softened water	Max. temp. [°C]	120★	80	140	80	90	80	90	80	140	80
	Max. conc. [%]										
	Suitability	+	+	++	+	+	+	+	+	++	+
	Comments	★ Seal face needs to be SiC ^G .									
Steam- containing water	Max. temp. [°C]			140	90	140	80			140	80
	Max. conc. [%]										
	Suitability	-	-	++	+	+	+	-	-	++	+
	Comments										

Coolants

Legend

- ++ = Best solution
- + = Suitable
- ± = Suitable under certain conditions
- = Not suitable

Liquid	Shaft seal (EN 12756)										
	Rotating face:	Q	Q	B	B	B	B	U	U	B	B
Stationary seat:	Q	Q	Q	Q	V	V	U	U	U	U	
Secondary seal:	E	V	E	V	E	V	E	V	E	V	
Spring:	G	G	G	G	G	G	G	G	G	G	
Other parts:	G	G	G	G	G	G	G	G	G	G	
Calcium chloride CaCl ₂	Max. temp. [°C]	5	5					5	5		
	Max. conc. [%]	35	35					35	35		
	Suitability	++	+	-	-	-	-	++	+	-	-
	Comments	Shaft seal with flush/double shaft seal may be required if the liquid contains additives; presence of oxygen entails risk of pitting on stainless steel parts.									
Ethanol (ethyl alcohol) C ₂ H ₅ OH	Max. temp. [°C]			75		75				75	
	Max. conc. [%]			100		100				100	
	Suitability	++	++	++	-	+	-	-	-	++	-
	Comments	Explosion hazard; highly inflammable; double shaft seal may be required; flash point: +12°C. ★ Seal face needs to be SiC ^G .									
Ethylene glycol (1,2-ethanediol) CH ₂ OHCH ₂ OH	Max. temp. [°C]	90	60					90	60		
	Max. conc. [%]	50	50					50	50		
	Suitability	++	+	-	-	-	-	++	+	-	-
	Comments	Shaft seal with flush/double shaft seal may be required if the liquid contains additives.									
Glycerine (glycerol) C ₃ H ₅ (OH) ₃	Max. temp. [°C]	80	80	80	80	80	80	80	80	80	80
	Max. conc. [%]	50	50	50	50	50	50	50	50	50	50
	Suitability	++	+	±	±	±	±	++	+	±	±
	Comments	Shaft seal with flush/double shaft seal may be required if the liquid contains additives.									
Methanol (methyl alcohol) CH ₃ OH	Max. temp. [°C]			65		65				65	
	Max. conc. [%]			100		100				100	
	Suitability	++	++	++	-	+	-	-	-	++	-
	Comments	Explosion hazard; highly inflammable; double shaft seal may be required; flash point: +11°C. ★ Seal face needs to be SiC ^G .									
Potassium carbonate K ₂ CO ₃	Max. temp. [°C]	90	20					90	20		
	Max. conc. [%]	40	2					40	2		
	Suitability	++	+	-	-	-	-	++	+	-	-
	Comments										
Propylene glycol (1,2-propanediol) CH ₂ OHCHOHCH ₃	Max. temp. [°C]	90	60					90	60		
	Max. conc. [%]	50	50					50	50		
	Suitability	++	+	-	-	-	-	++	+	-	-
	Comments										
Sodium chloride NaCl	Max. temp. [°C]	5	5					5	5		
	Max. conc. [%]	30	30					30	30		
	Suitability	++	+	-	-	-	-	++	+	-	-
	Comments	Shaft seal with flush/double shaft seal may be required if the liquid contains additives; presence of oxygen entails risk of pitting on stainless steel parts.									

Fuels

Legend

- ++ = Best solution
- + = Suitable
- ± = Suitable under certain conditions
- = Not suitable

Liquid	Shaft seal (EN 12756)										
	Rotating face:	Q	Q	B	B	B	U	U	B	B	
	Stationary seat:	Q	Q	Q	Q	V	V	U	U	U	
	Secondary seal:	E	V	E	V	E	V	E	V	E	
	Spring:	G	G	G	G	G	G	G	G	G	
	Other parts:	G	G	G	G	G	G	G	G	G	
Aviation fuel	Max. temp. [°C]	60				60				60	
	Max. conc. [%]										
	Suitability	-	+★	-	++	-	+	-	-	-	++
	Comments	Explosion hazard; insoluble in water; highly inflammable; double shaft seal may be required; freezing point -20°C; flash point: -40°C. ★ Seal face needs to be SiC ^G .									
Diesel oil	Max. temp. [°C]	60				60				60	
	Max. conc. [%]										
	Suitability	-	+★	-	++	-	+	-	-	-	++
	Comments	Insoluble in water; inflammable; double shaft seal may be required; flash point: +55°C. ★ Seal face needs to be SiC ^G .									
Jet fuel	Max. temp. [°C]	60				60				60	
	Max. conc. [%]										
	Suitability	-	+★	-	++	-	+	-	-	-	++
	Comments	Explosion hazard; insoluble in water; highly inflammable; double shaft seal may be required; flash point: +38°C. ★ Seal face needs to be SiC ^G .									
Petrol	Max. temp. [°C]	60				60				60	
	Max. conc. [%]										
	Suitability	-	+★	-	++	-	+	-	-	-	++
	Comments	Explosion hazard; insoluble in water; highly inflammable; double shaft seal may be required; freezing point -20°C; flash point: -40°C. ★ Seal face needs to be SiC ^G .									

Synthetic and mineral oils

Legend

- ++ = Best solution
- + = Suitable
- ± = Suitable under certain conditions
- = Not suitable

Liquid	Shaft seal (EN 12756)										
	Rotating face:	Q	Q	B	B	B	B	U	U	B	B
Stationary seat:	Q	Q	Q	Q	V	V	U	U	U	U	
Secondary seal:	E	V	E	V	E	V	E	V	E	V	
Spring:	G	G	G	G	G	G	G	G	G	G	
Other parts:	G	G	G	G	G	G	G	G	G	G	
Crude oil	Max. temp. [°C]	20		20		20		20		20	
	Max. conc. [%]										
	Suitability	-	++	-	±	-	-	-	+	-	±
	Comments	Explosion hazard; insoluble in water; double shaft seal recommended; risk of solid particles in liquid.									
Hydraulic oil, mineral-oil-based	Max. temp. [°C]	90		100		90		90		100	
	Max. conc. [%]										
	Suitability	-	+	-	++	-	+	-	+	-	++
	Comments	Insoluble in water; double shaft seal recommended at temperatures above +60°C; EPDM required for synthetic hydraulic oil.									
Motor oil	Max. temp. [°C]	90		120		120		90		120	
	Max. conc. [%]										
	Suitability	-	+	-	++	-	++	-	+	-	++
	Comments	Insoluble in water.									
Silicone oil	Max. temp. [°C]	90	90	100	140	90	90	90	90	100	140
	Max. conc. [%]	100	100	100	100	100	100	100	100	100	100
	Suitability	+	+	+	++	+	+	+	+	+	++
	Comments										
Tar oil	Max. temp. [°C]	90		140		90		90		140	
	Max. conc. [%]										
	Suitability	-	+	-	++	-	+	-	+	-	++
	Comments	Shaft seal with flush/double shaft seal recommended at temperatures above +40°C; depending on the hydrocarbon composition of the tar oil, the use of FFKM (Kalrez®) may be required.									
Vaseline oil	Max. temp. [°C]	90		125		90		90		125	
	Max. conc. [%]										
	Suitability	-	++	-	±	-	±	-	++	-	±
	Comments	Insoluble in water; risk of solid particles in liquid.									

Vegetable oils

Legend

- ++ = Best solution
- + = Suitable
- ± = Suitable under certain conditions
- = Not suitable

Liquid	Shaft seal (EN 12756)										
	Rotating face:	Q	Q	B	B	B	U	U	B	B	
Stationary seat:	Q	Q	Q	Q	V	V	U	U	U	U	
Secondary seal:	E	V	E	V	E	V	E	V	E	V	
Spring:	G	G	G	G	G	G	G	G	G	G	
Other parts:	G	G	G	G	G	G	G	G	G	G	
Corn oil	Max. temp. [°C]	90		120		120		90		120	
	Max. conc. [%]										
	Suitability	-	++	-	±	-	±	-	++	-	±
	Comments	Insoluble in water; risk of solid particles in liquid.									
Olive oil	Max. temp. [°C]	90		120		120		90		120	
	Max. conc. [%]										
	Suitability	-	++	-	±	-	±	-	++	-	±
	Comments	Insoluble in water; risk of solid particles in liquid.									
Peanut oil	Max. temp. [°C]	90		120		120		90		120	
	Max. conc. [%]										
	Suitability	-	++	-	±	-	±	-	++	-	±
	Comments	Insoluble in water; risk of solid particles in liquid.									
Rape seed oil	Max. temp. [°C]	90		120		120		90		120	
	Max. conc. [%]										
	Suitability	-	++	-	±	-	±	-	++	-	±
	Comments	Insoluble in water; risk of solid particles in liquid.									
Soya bean oil	Max. temp. [°C]	90		120		120		90		120	
	Max. conc. [%]										
	Suitability	-	++	-	±	-	±	-	++	-	±
	Comments	Insoluble in water; risk of solid particles in liquid.									

Solvents

Legend

- ++ = Best solution
- + = Suitable
- ± = Suitable under certain conditions
- = Not suitable

Liquid	Shaft seal (EN 12756)										
	Rotating face:	Q	Q	B	B	B	B	U	U	B	B
Stationary seat:	Q	Q	Q	Q	V	V	V	U	U	U	U
Secondary seal:	E	V	E	V	E	V	E	V	E	V	V
Spring:	G	G	G	G	G	G	G	G	G	G	G
Other parts:	G	G	G	G	G	G	G	G	G	G	G
Acetone (dimethyl ketone) CH ₃ COCH ₃	Max. temp. [°C]			60		60				60	
	Max. conc. [%]			100		100				100	
	Suitability	–	–	++	–	++	–	–	–	++	–
	Comments	Explosion hazard; highly inflammable; soluble in water; double shaft seal may be required; flash point: –18°C.									
Perchloroethylene (tetrachloroethene) C ₂ Cl ₄	Max. temp. [°C]		70		70		70		70		70
	Max. conc. [%]										
	Suitability	–	+	–	++	–	+	–	+	–	++
	Comments	Insoluble in water; double shaft seal recommended (highly toxic); avoid contact with aluminium and copper; risk of corrosion of stainless steel parts if liquid contains water.									
Toluene (methylbenzene) C ₆ H ₅ CH ₃	Max. temp. [°C]										
	Max. conc. [%]										
	Suitability	–	–	–	–	–	–	–	–	–	–
	Comments	Explosion hazard; highly inflammable; insoluble in water; double shaft seal may be required; flash point: +4.4°C; FFKM (Kalrez®) required.									
Trichloroethylene (trichloroethene) C ₂ HCl ₃	Max. temp. [°C]		20		20		20		20		20
	Max. conc. [%]										
	Suitability	–	+	–	++	–	+	–	+	–	++
	Comments	Insoluble in water; double shaft seal recommended (highly toxic); risk of corrosion of stainless steel parts if the liquid contains water.									
White spirit	Max. temp. [°C]				60		60				60
	Max. conc. [%]										
	Suitability	–	–	–	++	–	+	–	–	–	++
	Comments	Explosion hazard; inflammable; insoluble in water; double shaft seal may be required; flash point: +41°C.									
Xylene (dimethylbenzene) C ₆ H ₄ (CH ₃) ₂	Max. temp. [°C]										
	Max. conc. [%]										
	Suitability	–	–	–	–	–	–	–	–	–	–
	Comments	Explosion hazard; highly inflammable; insoluble in water; double shaft seal may be required (toxic); flash point: +29°C; FFKM (Kalrez®) required.									

Oxidants

Legend

- ++ = Best solution
- + = Suitable
- ± = Suitable under certain conditions
- = Not suitable

Liquid	Shaft seal (EN 12756)										
	Rotating face:	Q	Q	B	B	B	B	U	U	B	B
	Stationary seat:	Q	Q	Q	Q	V	V	U	U	U	U
	Secondary seal:	E	V	E	V	E	V	E	V	E	V
	Spring:	G	G	G	G	G	G	G	G	G	G
	Other parts:	G	G	G	G	G	G	G	G	G	G
Hydrogen peroxide H ₂ O ₂	Max. temp. [°C]	20	20	20	20	20	20				
	Max. conc. [%]	30	30	30	30	30	30				
	Suitability	++	++	++	++	++	++	-	-	-	-
	Comments	Double shaft seal recommended for high concentration.									
Sodium hypochlorite (bleaching liquid) NaClO	Max. temp. [°C]	20	20								
	Max. conc. [%]	1	1								
	Suitability	±	±	-	-	-	-	-	-	-	-
	Comments	Risk of pitting on stainless steel parts.									

Organic compounds

Legend

- ++ = Best solution
- + = Suitable
- ± = Suitable under certain conditions
- = Not suitable

Liquid	Shaft seal (EN 12756)										
	Rotating face:	Q	Q	B	B	B	B	U	U	B	B
Stationary seat:	Q	Q	Q	Q	V	V	U	U	U	U	
Secondary seal:	E	V	E	V	E	V	E	V	E	V	
Spring:	G	G	G	G	G	G	G	G	G	G	
Other parts:	G	G	G	G	G	G	G	G	G	G	
Benzene (petroleum naphtha) C ₆ H ₆	Max. temp. [°C]										
	Max. conc. [%]										
	Suitability	-	-	-	-	-	-	-	-	-	-
	Comments	Explosion hazard; highly inflammable; toxic; insoluble in water; double shaft seal may be required; flash point: -11°C; FFKM (Kalrez [®]) recommended.									
Butanol (butyl alcohol) C ₄ H ₇ OH	Max. temp. [°C]			40	80	40	80			40	80
	Max. conc. [%]			100	100	100	100			100	100
	Suitability	++	++	+	++	+	+	-	-	+	++
	Comments	Explosion hazard; highly inflammable; soluble in water; double shaft seal may be required; flash point: +37°C. ★ Seal face needs to be SiC ^G .									
Hexane C ₆ H ₁₄	Max. temp. [°C]				20		20				20
	Max. conc. [%]				100		100				100
	Suitability	++	++	-	++	-	+	-	-	-	++
	Comments	Explosion hazard; highly inflammable; insoluble in water; double shaft seal may be required; flash point: -22°C. ★ Seal face needs to be SiC ^G .									
Isopropyl alcohol CH ₃ CHOHCH ₃	Max. temp. [°C]	70	80	70	80	70	80	70	80	70	80
	Max. conc. [%]	100	100	100	100	100	100	100	100	100	100
	Suitability	+	+	+	++	+	+	+	+	+	++
	Comments	Explosion hazard; highly inflammable; soluble in water; double shaft seal may be required; flash point: +11.7°C.									
Naphthalene C ₁₀ H ₈	Max. temp. [°C]		80		80		80		80		80
	Max. conc. [%]		100		100		100		100		100
	Suitability	-	++	-	+	-	+	-	++	-	+
	Comments	Insoluble in water; inflammable; double shaft seal recommended: flash point: +79°C.									
Propanol (propyl alcohol) CH ₃ CH ₂ CH ₂ OH	Max. temp. [°C]	80	80	80	80	80	80	80	80	80	80
	Max. conc. [%]	100	100	100	100	100	100	100	100	100	100
	Suitability	+	+	+	++	+	+	+	+	+	++
	Comments	Explosion hazard; highly inflammable; soluble in water; double shaft seal may be required; flash point: +22°C.									
Triethanolamine N(C ₂ H ₄ OH) ₃	Max. temp. [°C]	60		60		60		60		60	
	Max. conc. [%]	10		10		10		10		10	
	Suitability	++	-	+	-	+	-	++	-	+	-
	Comments	Soluble in water.									

Miscellaneous

Legend

- ++ = Best solution
- + = Suitable
- ± = Suitable under certain conditions
- = Not suitable

Liquid	Shaft seal (EN 12756)											
	Rotating face: Stationary seat: Secondary seal: Spring: Other parts:	Q	Q	B	B	B	B	U	U	B	B	
Cider	Max. temp. [°C]	90	60	120	60	90	60	90	60	120	60	
	Max. conc. [%]											
	Suitability	+	+	++	+	+	+	+	+	++	+	
	Comments											
Sugar	Max. temp. [°C]	90	80	120	80	90	80	90	80	120	80	
	Max. conc. [%]	<100	<100	<100	<100	<100	<100	<100	<100	<100	<100	
	Suitability	++	+	±	±	±	±	++	+	±	±	
	Comments	Shaft seal with flush/double shaft seal recommended.										
Vinegar	Max. temp. [°C]	60	60	60	60	60	60	60	60	60	60	
	Max. conc. [%]	<100	<100	<100	<100	<100	<100	<100	<100	<100	<100	
	Suitability	+	++	+	++	+	+	+	++	+	++	
	Comments											

Shaft seal failure analysis guide

The table below is intended as a general guide of typical seal failures.

On the following pages are examples of the most common causes of seal failures.

Component	Result of visual examination	Possible causes of failure																
		Abrasion	Poor lubrication	Contamination	Corrosion	Poor thermal control		Incorrect installation			System faults							
						Cooling	Heating	Assembly	Fitting	Misalignment	Flow	Pressure	Temperature	Poor venting	Cleaning (treatment)	Vibration		
Seal	Good condition					1	1		2									
	Noise		13						7				15	13	13		16	
	Seized				11											5		
	Clogged			17/18					19									
Seal faces	Decomposed	18			11													
	Chipped		15						10								16	
	Etched	18			11											5		
	Flaked		13						10									
	Galled		13			6												
	Grooved	18	20	8		15		19	7						4			
	Incomplete track																	
	Matted																	
	Pitted																	
	Scored/scuffed																	
	Excessively worn	18	20	8	11	15			7			4	13	13	4	5		
	Discoloured				21		3											
	Deposits			9/17						22				15				
	Blistered	18	24		23					10								
	Fractured		3							10		4			3			16
Cracked				11		13			10				13	3			16	
Elastomers	Chipped								10							25		
	Burnt		3		11						4	15	13	3				
	Swollen				11								13		11			
	Decomposed											28	12	3				
	Fractured																27	
	Extruded								19	10			13	13				
	Ruptured									10			27				27	
Metal parts	Worn												26	28	13			
	Fractured		15		11								28	13			16	
	Discoloured				11											5		
	Etched				11											5		
	Pitted				11											5		
Shaft/pipe	Worn				11							14/26		28				
	Ruptured		15											13				
	Cracked		15											13				
	Pitted				11											5		

Key to failure analysis

Failure number	Description of possible causes of failure
1	Seal opens due to differential expansion between stationary and rotating parts, caused by deposits preventing the rotating ring from moving axially on the shaft.
2	Seal is not set to correct working length, resulting in no contact between face and seat.
3	Seal faces are running dry, resulting in overheating. High torque on seal faces made of hard materials can generate heat that can be transmitted to elastomers, resulting in hardening and burning.
4	Closed pump outlet valve results in excessive temperature or failure no. 3.
5	Chemical reaction with an oxidizing agent, e.g. nitric acid.
6	Insufficient flow to heat exchanger or cooled hollow seat, resulting in failure no. 3.
7	Overcompression due to incorrect assembly or incorrect working length, resulting in failure no. 3.
8	Solid particles, such as sodium hydroxide crystals, precipitate out of liquid across seal contact face. Use hard faces and/or flush seal.
9	Volatile elements of liquid evaporate in seal gap, leaving highly viscous, sticky layers on seal faces. Use hard faces and double seal.
10	Damage due to mishandling or overcompression.
11	Seal material not chemically resistant to liquid or contaminant.
12	Material has decomposed due to temperatures beyond limitations.
13	Seal has been exposed to pressure/temperatures in excess of limits.
14	Continual removal of passive film due to relative movement.
15	System pressure is below or close to vapour pressure.
16	Check bearings.
17	Liquid is saturated with scale.
18	Solid particles in liquid. Hard seal faces required.
19	Wrong assembly.
20	Longer life with cool top is expected.
21	Corrosion makes tungsten carbide appear mat grey or green.
22	By electrochemical deposition, metals such as copper may form on the seal face due to missing or poor electrical grounding of pump.
23	In water of a conductivity below 5 microSiemens/cm, some SiC grades corrode. Use Qg seal faces.
24	Excessive heat dissipation may cause blistering of carbon. Reduce speed, spring load or pressure, or change to metal-impregnated carbon.
25	Elastomers fitted on uncleaned surfaces.
26	Seat is misaligned, check for debris or deposits on seal faces.
27	Explosive decompression on account of heat build-up may take place due to misalignment, failure no. 26, or vibration, failure no. 16.
28	Start/stop at excessive system pressure with hard seal faces.

Further product documentation

Sources of product documentation

In addition to the printed data booklet, Grundfos offers the following sources of product documentation.

- WinCAPS
- WebCAPS.

WinCAPS

WinCAPS is a **Windows-based Computer-Aided Product Selection** program containing information on more than 90,000 Grundfos products.

Available on CD-ROM in more than 15 languages, WinCAPS offers

- detailed technical information
- selection of the optimum pump solution
- dimensional drawings of each pump
- detailed service documentation
- installation and operating instructions
- wiring diagrams of each pump.



Fig. 66 WinCAPS CD-ROM

cd-wincaps

Click on **Catalogue** and select a product from the extensive product catalogue.

Click on **Sizing** and select the most suitable pump for your application.



Fig. 67 WinCAPS

WinCAPS

Further product documentation

WebCAPS

WebCAPS is a **Web**-based **Computer Aided-Product Selection** program and a web-version of WinCAPS.

Available on Grundfos' homepage, www.grundfos.com, WebCAPS offers

- detailed technical information
- dimensional drawings of each pump
- wiring diagrams of each pump.

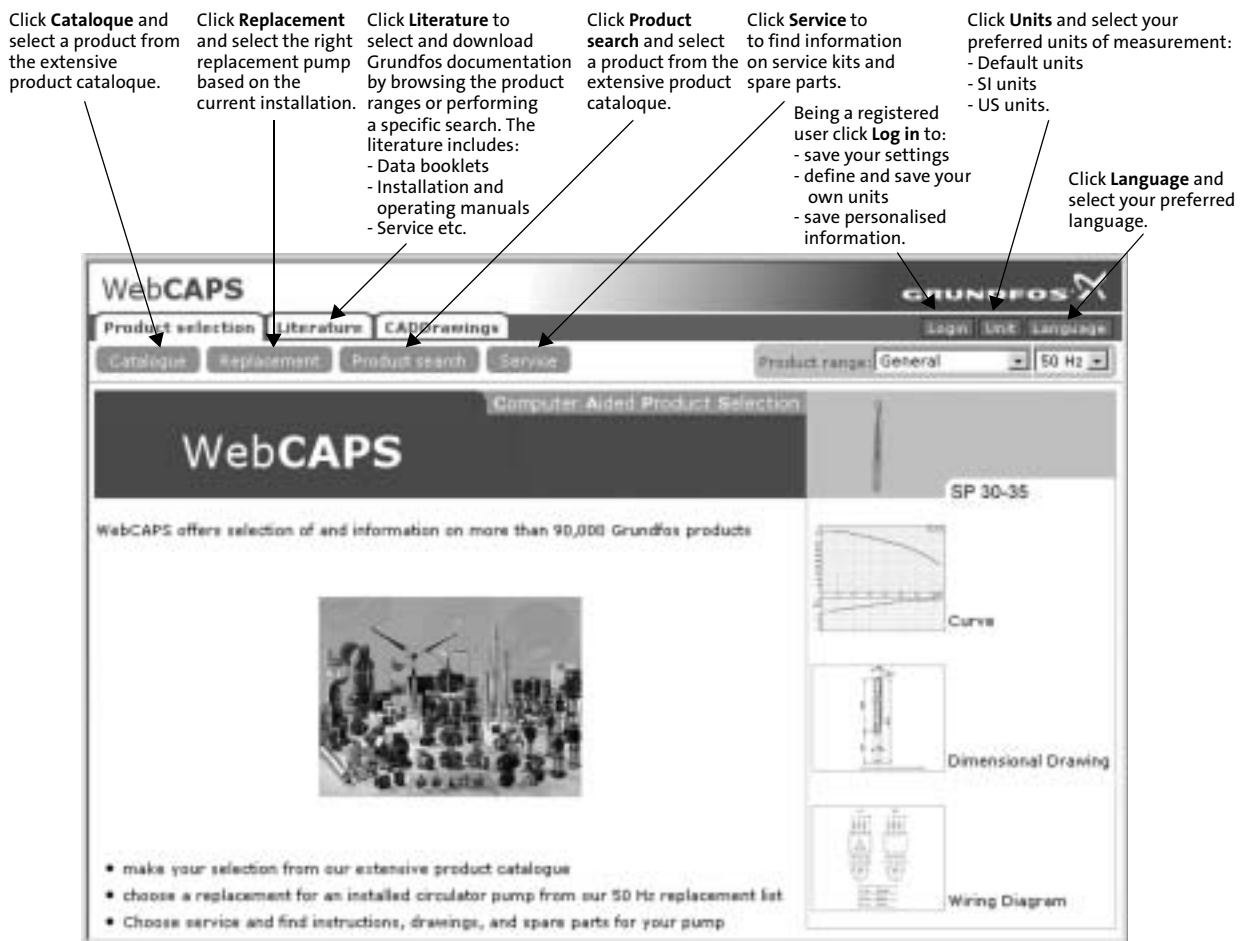

Fig. 68 WebCAPS

WebCAPS

96 51 98 75 01 04	GB

Subject to alterations.