

PT. LUKES INDONESIA

Lindeteves Trade Center Lt UG, Blok B1 No. 6  
Jalan Hayam Wuruk, Jakarta - Indonesia  
Phone : 021 - 6231 7842, 628 5144  
Fax : 021 - 6231 0499  
email : lukes@cbn.net.id



## AP, KP

Wastewater pumps  
50 Hz



# Contents

## General data

Performance range	Page	3
Applications	Page	5
Examples of application	Page	5
Pump overview	Page	6
Type key for AP pumps	Page	6
Type key for KP pumps	Page	6
Construction	Page	7
Installation	Page	7
Sectional drawing	Page	7

## Technical data

KP	Page	8
AP10	Page	11
AP12	Page	14
AP30	Page	17
AP35	Page	20
AP35B	Page	23
AP50	Page	26
AP50B	Page	29
AP51	Page	32
AP65 Vortex	Page	35
AP70	Page	40
Control box	Page	44
AP80 Vortex	Page	45
AP100	Page	57

## Accessories

LC 107, LCD 107	Page	71
LC 108, LCD 108	Page	72
Dimensions	Page	73
Level switches	Page	73
Explosion protection unit, LC Ex 4	Page	73
Accessories for AP, KP stainless steel pumps	Page	74
Accessories for cast iron AP pumps	Page	75
Level controllers and accessories	Page	78
Free-standing installation or portable	Page	79
Installation on auto-coupling	Page	79
Vertical dry installation (D)	Page	79
Pipe dimensions	Page	80

## Product range

KP 150	Page	81
KP 250	Page	82
KP 350	Page	83
AP10	Page	84
AP12	Page	84
AP30	Page	85
AP35	Page	85
AP35B	Page	85
AP50	Page	86
AP50B	Page	86
AP51	Page	87
AP65 Vortex	Page	88
AP70	Page	88
AP80 Vortex standard version	Page	89
AP100 standard version	Page	90

AP10 Ex-version	Page	91
AP30 Ex-version	Page	91
AP51 Ex-version	Page	91
AP65 Vortex Ex-version	Page	91
AP70 Ex-version	Page	91
AP80 Vortex Ex-version	Page	92
AP100 Ex-version	Page	93

## Performance range

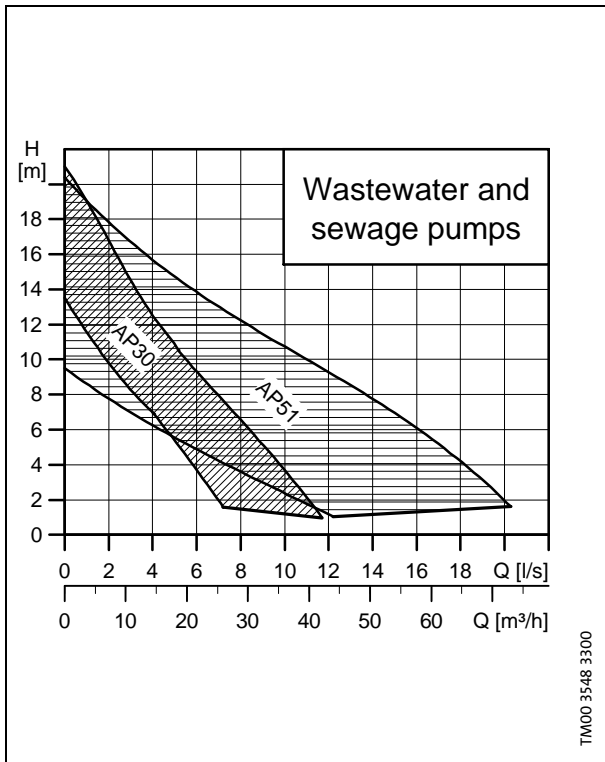
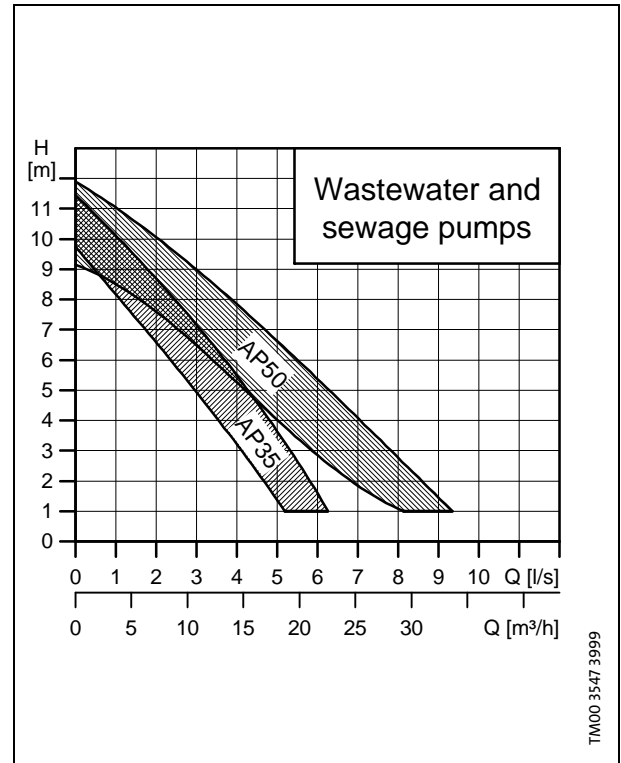
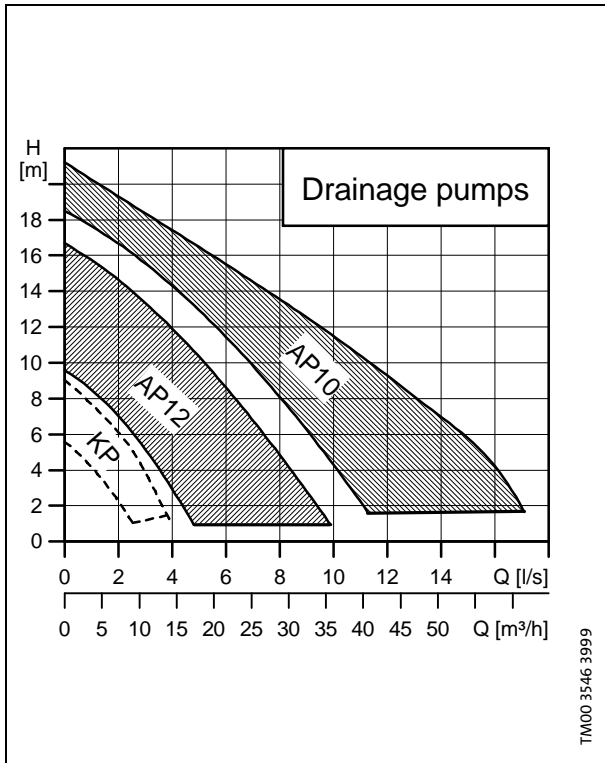

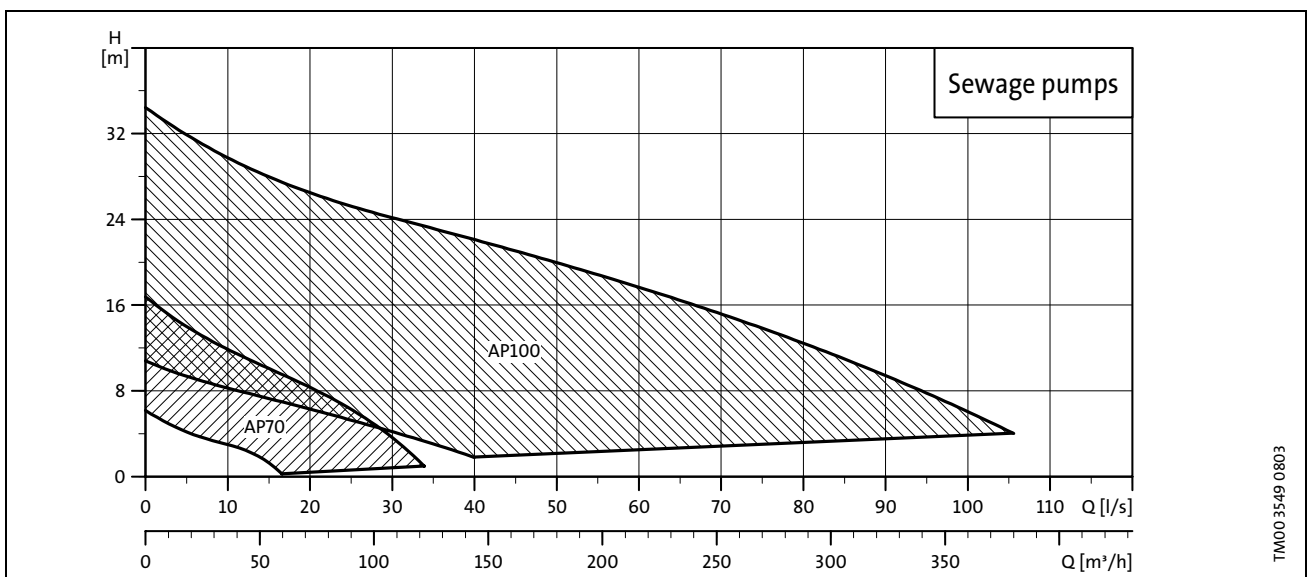
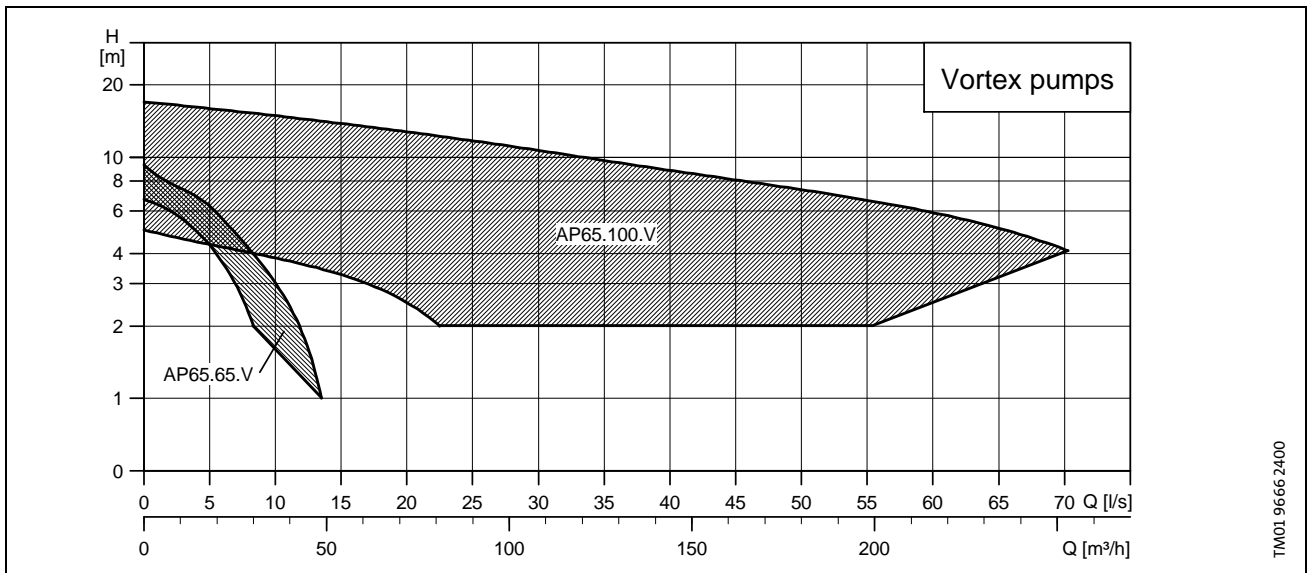
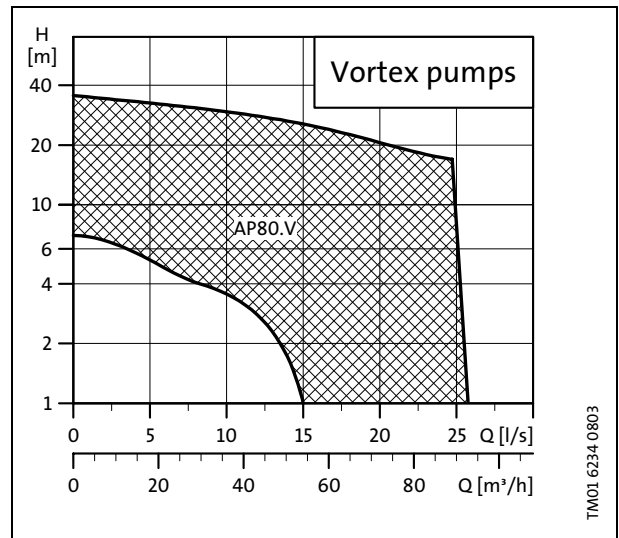
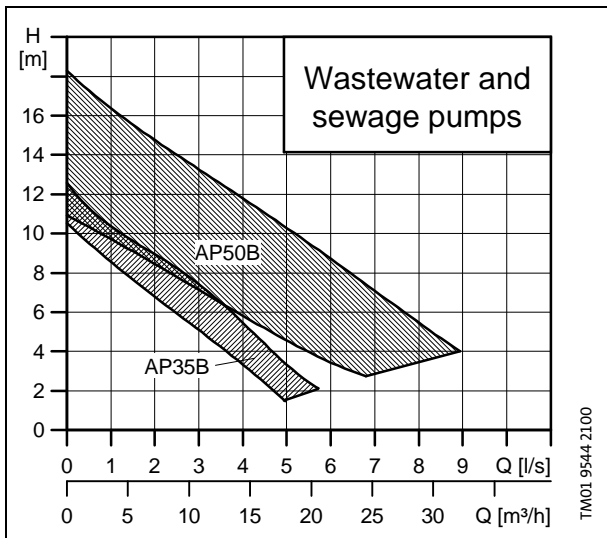

## Applications

The KP and AP pumps are suitable for temporary as well as permanent free-standing installation. Furthermore AP pumps are suitable for installation on an auto-coupling at the bottom of a pit with guide rails going to the top.

The AP100 pump is available for dry pit installation.

The pumps are designed for intermittent operation.

pH value for KP pumps: 4 to 9.

pH value for AP pumps: 4 to 10.

Maximum density: 1.100 kg/m<sup>3</sup>

Maximum installation depth below water level: 10 m.

For permanent installation, level controllers are available: LC 107 and LC 108 for one-pump installations and LCD 107 and LCD 108 for two-pump installations.

Explosion-proof versions of the AP pumps are available for applications involving the risk of explosion.

Classification: EN 50 014/18/19/20 - 1977 (BS 5501), class EEx d(e) (ib) IIB T4.

## Examples of application

	KP	AP 10	AP 12	AP 30	AP 35	AP 35B	AP 50	AP 50B	AP 51	AP65 Vortex	AP 70	AP80 Vortex	AP 100
<b>Max. liquid temperature</b>	50°C	40°C	55°C	40°C	55°C	40°C	55°C	40°C	40°C	40°C	40°C	40°C	40°C
Pumping of wastewater from rivers and lakes		●	●	●	●	●	●	●	○	○	○	○	○
Pumping of drainage water and flood water	●	●	●	●	●	●	●	●	○	○	○	○	○
Pumping of surface rainwater	●	●	●	●	●	●	●	●	●	○	●	○	○
Pumping of ditch and excavation drainage water	●	●	●	●	●	●	●	●	●	○	●	○	
Pumping of drainage water from garage sprinkler systems		●	○	●	○	○	○	○	●	○	●	○	○
Mobile use for contractors, installers and industry		●	●	●	●	●	●	●	●	○	○	○	○
Filling/emptying of containers	●	●	●	●	●	●	●	●	●	○		○	
Transfer of liquids in industry, etc.		●	●	●	●	●	●	●	●	●	●	●	●
Pumping of effluents from tunnels, underground garages etc.		●	●	●	●	●	●	●	●	●	●	●	●
Pumping of sewage from single and multi-family dwellings										●	●	●	●
Pressurized pumping of sewage from camp sites, service areas and remote buildings												●	
Pressurized pumping of sewage from public buildings and small factories												●	
Pumping of sewage from private toilets, showers, swimming pools etc. below sewer level							●	●	●	●	●	●	○
Pumping of wastewater from single and multi-family homes, camp sites and sports stadiums							○	○	○	●	●	●	
Pumping of sewage in municipal applications										●	●	●	●
Pumping of sewage from hotels, restaurants, cinemas, schools and public buildings										●	●	●	●
Pumping of wastewater from underground stations and public swimming pools										●	●	●	●

● = Recommended pump type

○ = Alternative pump type

## Pump overview

Pump range	Free passage [mm]	Impeller type	Number of motor poles	Explosion-proof versions available
KP	10	Semi-open	2	No
AP10	10	Semi-open	2	Yes
AP12	12	Semi-open	2	No
AP30	30	Open single-channel	2	Yes
AP35	35	Vortex	2	No
AP35B	35	Vortex	2	No
AP50	50	Vortex	2	No
AP50B	50	Vortex	2	No
AP51	50	Single-channel	2	Yes
AP65 Vortex	65	Vortex	4	Yes
AP70	70	Single-channel	4	Yes
AP80 Vortex	80	Vortex	2 or 4	Yes
AP100	100	Single channel or two-channel	4 or 6	Yes

## Type key for AP pumps

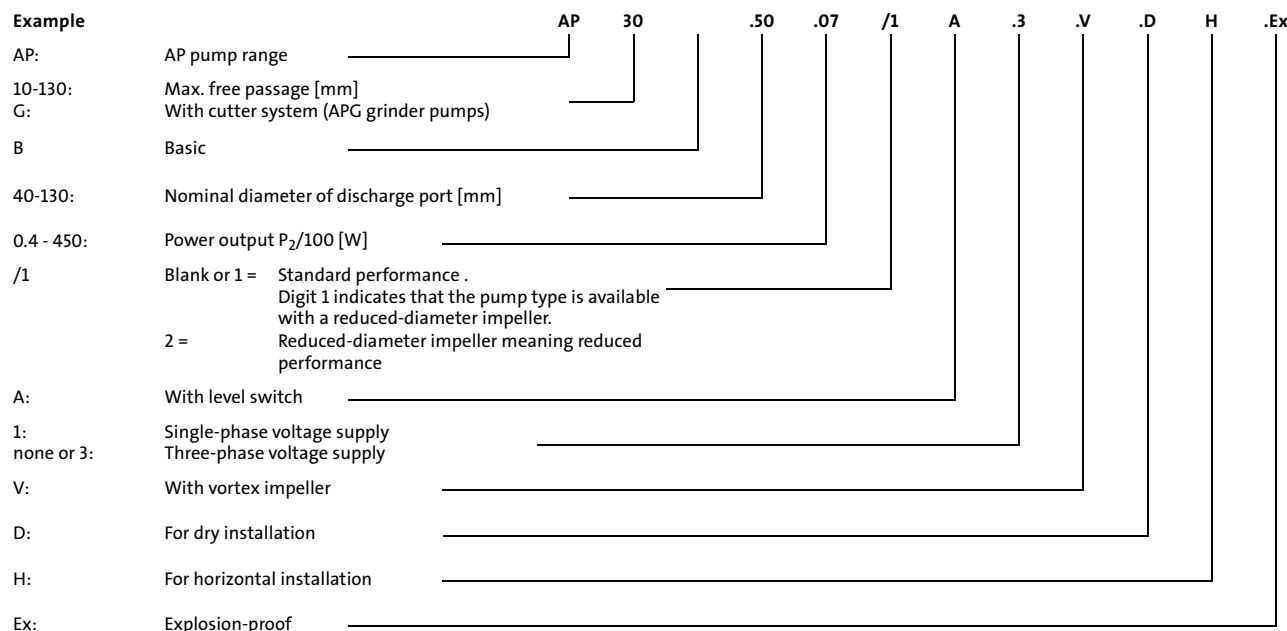

## Type key for KP pumps

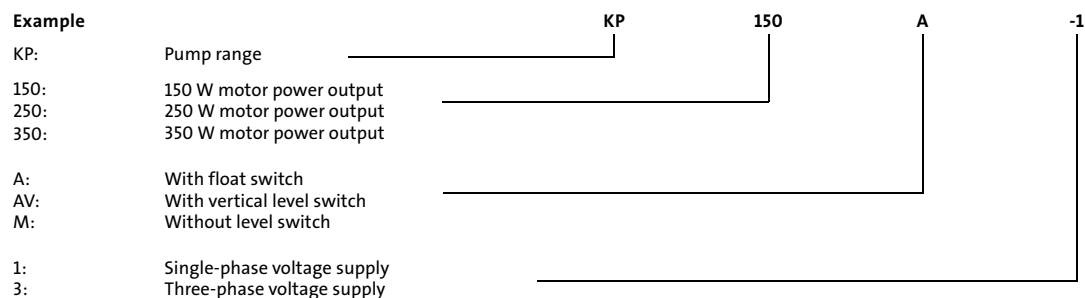

## Construction

Vertical, single-stage, submersible centrifugal pumps with horizontal or vertical discharge port designed for free-standing installation or installation by means of an auto-coupling guide rail system or for pit installation.

The pumps are directly connected to an asynchronous submersible motor for 1 x 230 V +6/-10%, 3 x 230 V +6/-10% or 3 x 400 V +6/-10%, 50 Hz.

Enclosure class: IP 68.  
Insulation class: F (155°C).

### Stainless steel pumps

**Single-phase pumps** incorporate thermal overload protection and require no additional motor protection.

**Three-phase pumps** must be connected to a motor starter.

### Cast iron pumps

**APG pumps** have a built-in thermal protection which cuts off the motor in case of overload. The motor restarts automatically; **Ex-pumps**, however, require manual restart.

**Three-phase Ex-pumps** have a thermal switch in the motor windings. The thermal switch is to be connected to the control circuit of a motor starter. **Ex-pumps** require manual restart.

Some **three-phase pumps** have a thermal switch in the motor windings.

## Installation

The pumps are suitable for free-standing installation as well as installation on an auto-coupling guide rail system, which is available as an accessory.

AP80 Vortex and AP100 pumps are suitable for vertical or horizontal dry pit installation.

Pumps in permanent submersible installations can be installed by means of a stationary auto-coupling at the bottom of the pit. Two guide rails going to the top of the pit ensure that the pump is positioned correctly when lowered from the top of the pit down to the auto-coupling and connected to the pipe system. Due to this system, the pump can easily be pulled up for service.

Pumps for vertical dry pit installation can be installed by means of a stationary dry pit stand with suction bend.

For free-standing installation the AP70 and AP100 pumps must be fitted with a base stand, see accessories.

## Sectional drawing

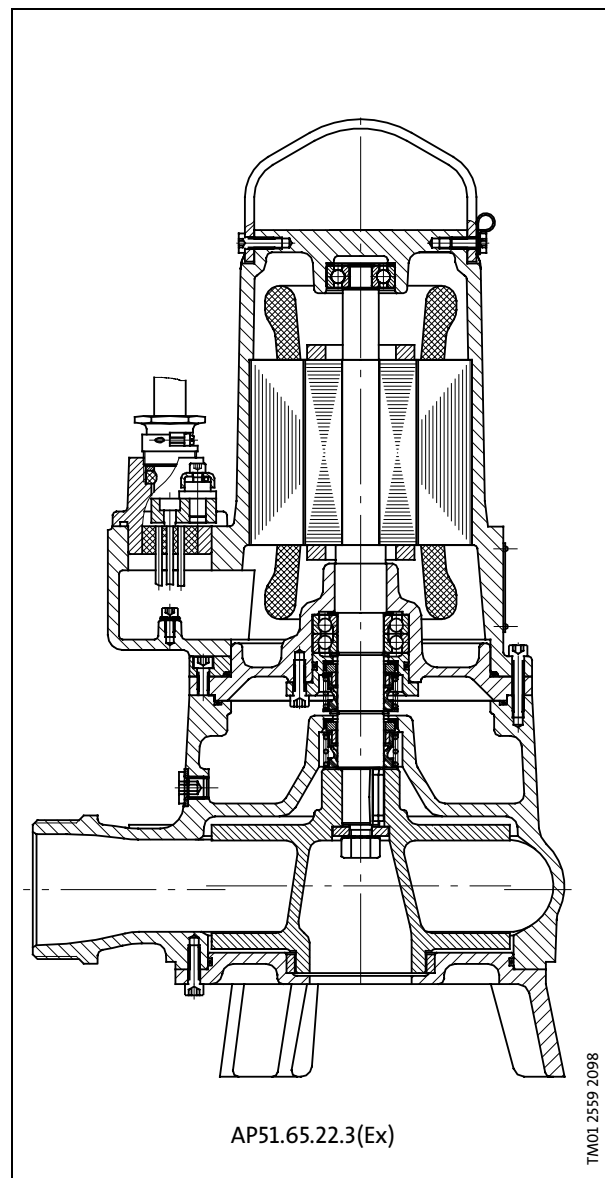

## KP



The KP pump is designed for liquid transfer and drainage of clean or slightly dirty waste water with the pump completely or partly submerged in the liquid.

- drainage of cellars or buildings,
- pumping of domestic waste water without toilet waste,
- groundwater lowering,
- emptying applications, eg. in pools, tanks and vessels and
- pumping applications within agriculture, dairy industry, horticulture and process industry.

## Approvals

Z-53.3-408 according to Institut für Bautechnik, Berlin

## Pumped liquids

### Pumps without level switch or with float switch:

The pump is suitable for the pumping of

- clean, non-aggressive water and
- slightly dirty (grey) waste water.

If the pump has been used for other liquids than clean water, it should be flushed through with clean water immediately after use. The open impeller construction ensures a free passage of solids up to a diameter of  $\phi 10$  mm.

### Pumps with vertical level switch:

The pump must only be used for the pumping of clean ground water and drain water.

## Operating range

Installation depth: Max. 10 metres below liquid level.

Min. liquid temperature: 0°C.

Max. liquid temperature at continuous operation: 50°C.

During continuous pumping the suction strainer must always be completely covered by the liquid.

Max. liquid temperature: 70°C for periods not exceeding 2 minutes at intervals of at least 30 minutes.

## Discharge

KP 150, KP 250 and KP 350: Rp 1½

## Pump sleeve and housing

Single-stage, submersible, stainless steel, drainage pump in a robust design with upwards-pointing discharge port placed on top of the pump.

The water enters the pump through the holes of the suction strainer preventing the passage of large solids. The sturdy impeller has single curved vanes with bevelled front edges that prevent fibres from jamming the impeller. The guide vanes in the pump housing not only guide the liquid but also lift sand grains into the liquid flow and thus prevent blocking by sand.

The outer casing is made in one piece. The mains cable and the cable of the level switch are combined in one vulcanized and watertight plug, which is secured to the socket of the hermetically sealed stator housing.

## Motor

The motor is a single- or three-phase, asynchronous canned motor with liquid-filled rotor chamber and water lubricated bearings. The motor is cooled by the pumped liquid around the motor.

Enclosure class: IP 68.

Insulation class: F.

The motor incorporates automatic overload protection which cuts out the motor in case of overload. When it has cooled to normal temperature, the motor will restart automatically.

## Materials

Components	Materials	DIN W.-Nr.	AISI
Outer casing	Stainless steel	1.4301	304
Pump housing	Stainless steel	1.4301	304
Suction strainer	Stainless steel	1.4301	304
Impeller	Stainless steel	1.4301	304
Shaft	Stainless steel	1.4057	431
Stator housing	Stainless steel	1.4301	304
Guide vanes	Stainless steel	1.4301	304
Bearings	Carbon		
O-rings Seal rings	NBR		
Cables	H 07 RN-F		



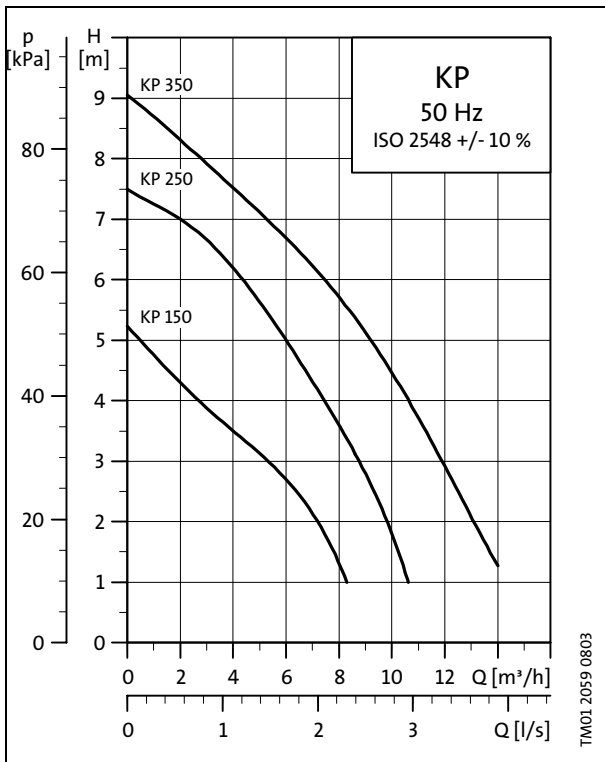

Pump type	Voltage	P <sub>1</sub> [W]	I <sub>n</sub> [A]	Dimensions [mm]						Weight [kg]
				H	B1	B2	L1	L2	L3	
KP 150	1 x 220-230 V	300	1.3	225	149	31	350	400	70	6.3
KP 150	1 x 230-240 V	300	1.3	225	149	31	350	400	70	6.3
KP 250	1 x 220-230 V	480	2.3	225	149	31	350	400	70	7.2
KP 250	1 x 230-240 V	480	2.2	225	149	31	350	400	70	7.2
KP 250	3 x 380-415 V	480	0.8	225	149	31	350	400	70	7.2
KP 350	1 x 220-240 V	700	3.2	235	149	31	350	410	70	8.0
KP 350	3 x 380-400 V	700	1.3	235	149	31	350	410	70	8.0

### With float switch

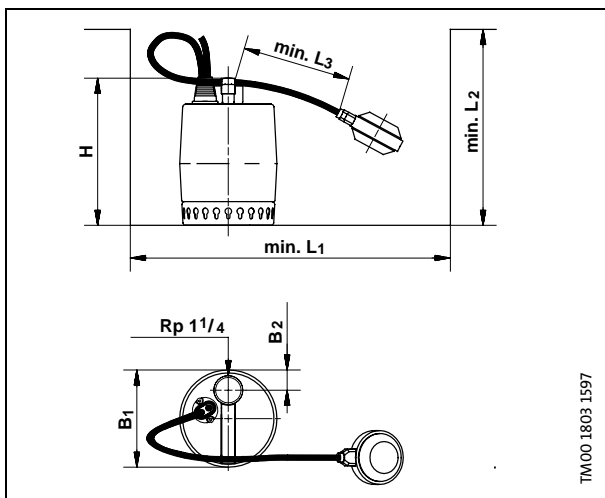

### With vertical level switch

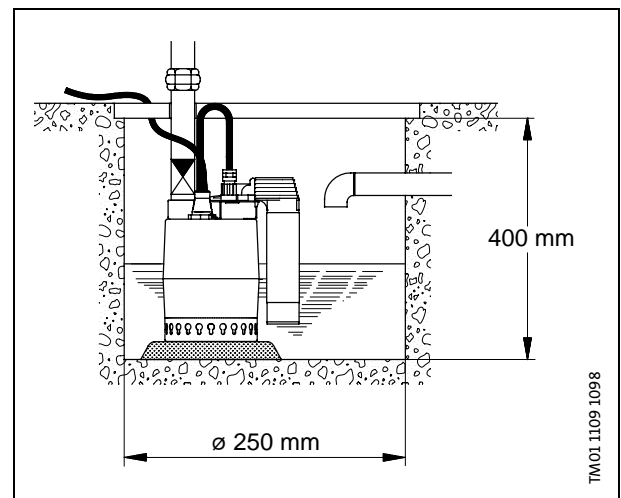

## Installation

Pumps without level switch or with float switch can be used in vertical position with the discharge port uppermost or in horizontal or tilted position with the discharge port as the highest point of the pump.

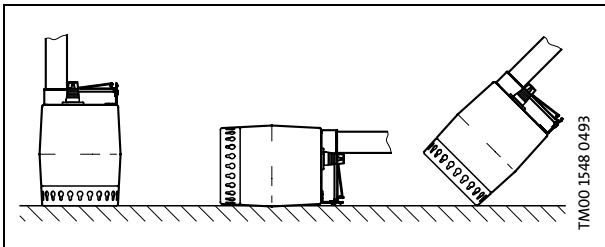

Pumps with vertical level switch must be used in vertical position.

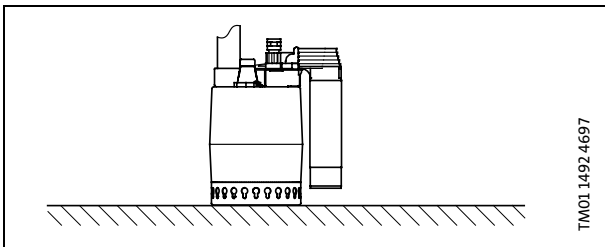

The KP pump is well suited for permanent installation.

## Level switches

A level switch, which gives impulses to start/stop between two levels of liquid, is connected to pumps intended for automatic operation. This type of installation requires a non-return valve in the discharge pipe or in the pump. The pumps are available with two different types of level switches.

Min. liquid level: – manual operation: 14 mm.  
– automatic operation: See below.

### Pumps with float switch:

A clamp on the handle of the pump holds the cable of the level switch. The difference in level between start and stop can be adjusted by changing the free cable length between the handle of the pump and the level switch.

Dimensions for KP 350 are marked with "★".

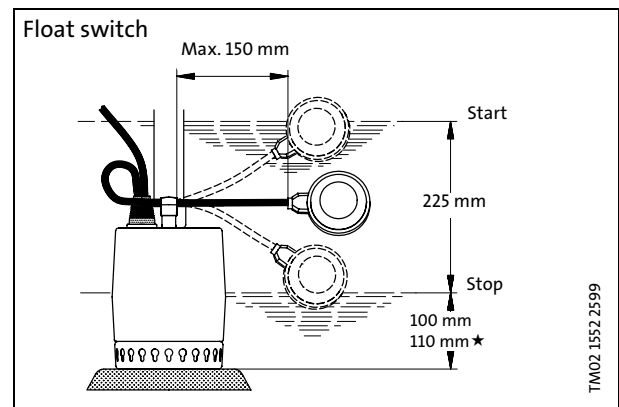

### Pumps with vertical level switch:

For pumps with vertical level switch, the difference in level between start and stop is not adjustable.

Dimensions for KP 350 are marked with "★".

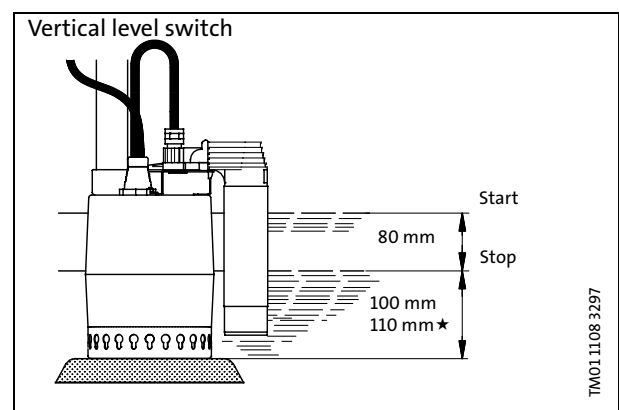

## AP10



The pumps are used for pumping wastewater, sludge-containing water, ground water and surface water in places such as

- sumps,
- shafts,
- ducts,
- tunnels,
- excavations,
- basements,
- cellars and
- underground car parks.

AP10 pumps are ideal for general flood relief applications and for miscellaneous industrial applications.

## Pump and stator housing

The pump housing and stator housing are made of cast iron.

The stator housing is dry, i.e. not oil-filled.

## Discharge

All AP10 pumps have a horizontal discharge port for threaded connection.

AP10.50.Ex: R 2.

AP10.65: R 2½.

## Shaft and bearings

The shaft is made of stainless steel and rotates in maintenance-free prelubricated ball bearings.

The lower bearing is a double-row ball bearing.

## Impeller

The impeller is a semi-open cast iron impeller with a clearance of 10 mm in the pump housing. Cast iron is chosen as it is resistant towards mechanically wearing particles.

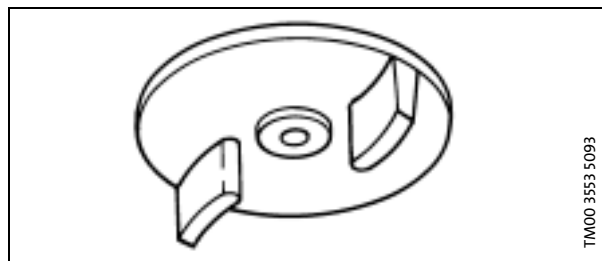

An adjustable cast iron wear plate is fitted at the inlet side of the impeller.

## Shaft seals

AP10.50.12.3Ex: Combination of mechanical shaft seal and lip seal.

The primary shaft seal has silicon carbide/silicon carbide seal faces. The secondary shaft seal is a lip seal. The chamber between the shaft seals is filled with 0.04 litre of oil.

AP10.65.21: Two mechanical bellows seals with silicon carbide/silicon carbide seal faces. The chamber between the shaft seals is filled with 1.2 litre of oil.

## Motor cable

Standard pumps 10 m: H07RNF.

Ex-pumps 10 m: H07RNF - PLUS.

## Materials

Description	Materials	DIN W.-Nr.	AISI/ASTM
Strainer	Cast iron EN-GJL-250	0.6025	ASTM 35B
Stator housing	Cast iron EN-GJL-250	0.6025	ASTM 35B
Pump housing	Cast iron EN-GJL-250	0.6025	ASTM 35B
Wear plate	Cast iron EN-GJL-250	0.6025	ASTM 35B
Impeller	Cast iron EN-GJL-250	0.6025	ASTM 35B
Shaft	Stainless steel	1.4104	AISI 430F
Bearings	Heavy-duty prelubricated ball bearings		
Screws	Stainless steel	1.4301	AISI 304
Oil	Shell Ondina 15, non-toxic		

## Control box

Further information about control box, float switch, and level control, see page 44.

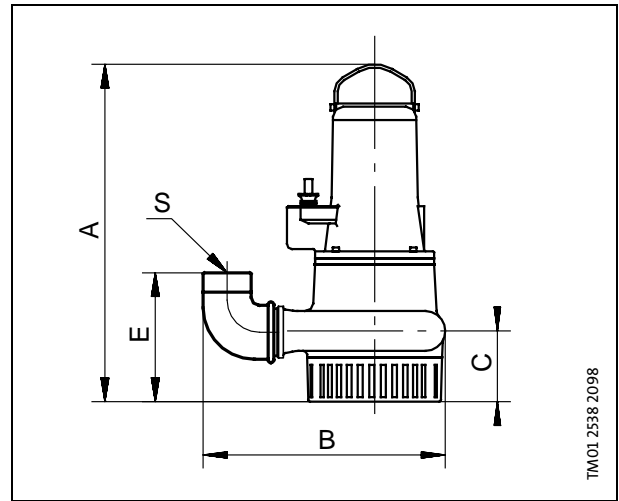
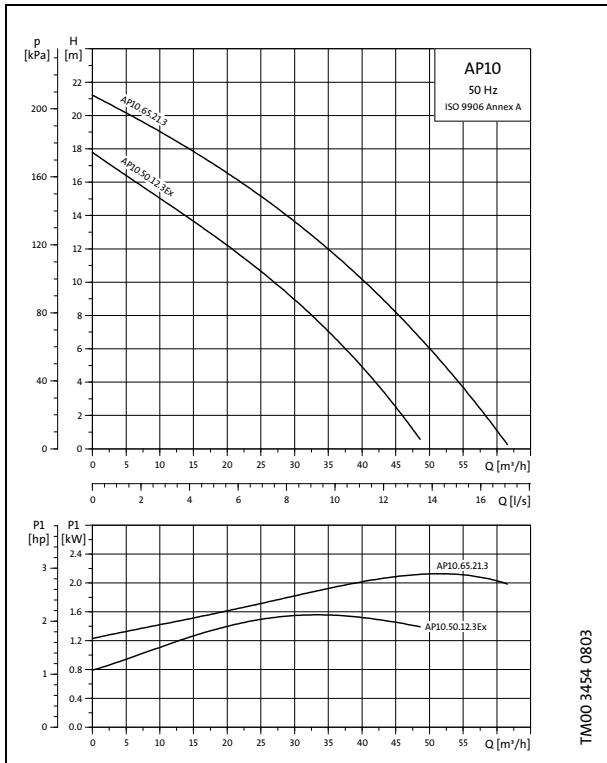

Pump type	Voltage	P <sub>1</sub> [kW]	P <sub>2</sub> [kW]	n [min <sup>-1</sup> ]	I <sub>n</sub> [A]	Cos φ	I <sub>start</sub> /I <sub>n</sub>	Dimensions [mm]					Weight ★ [kg]
								A	B	C	E	S	
AP10.50.12.3.Ex	3 x 400 V	1.60	1.20	2850	2.9	0.84	4.6	426	300	87	161	R 2	30
AP10.50.12.3.Ex	3 x 230 V	1.60	1.20	2850	2.9	0.84	4.6	426	300	87	161	R 2	30
AP10.65.21.3	3 x 400 V	2.50	2.10	2800	4.5	0.84	4.6	525	380	108	198	R 2½	27
AP10.65.21.3	3 x 230 V	2.50	2.10	2800	7.8	0.84	4.7	525	380	108	198	R 2½	27
AP10.65.21.A.3	3 x 400 V	2.50	2.10	2800	4.5	0.84	4.6	525	380	108	198	R 2½	27
AP10.65.21.A.3	3 x 230 V	2.50	2.10	2800	7.8	0.84	4.7	525	380	108	198	R 2½	27

★ Pump inclusive of cable.

## AP10 installations

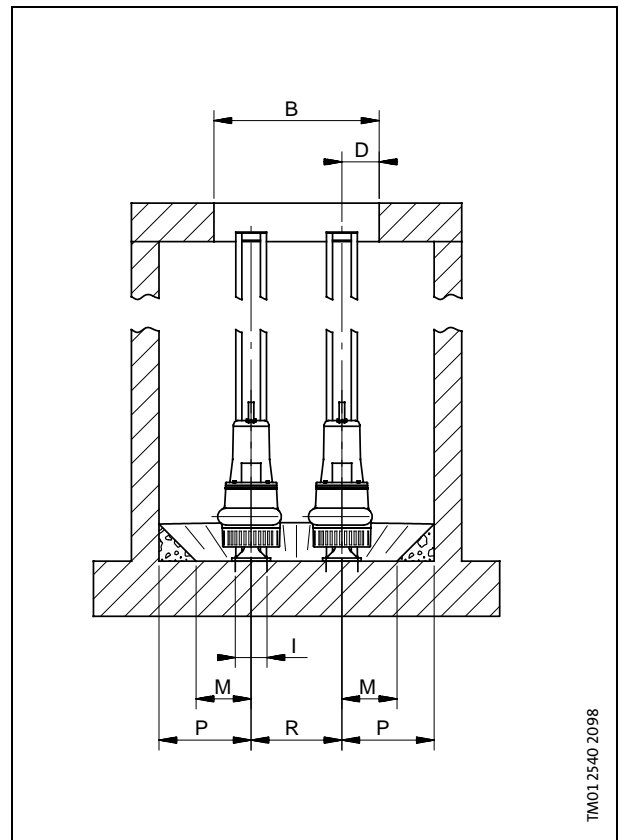
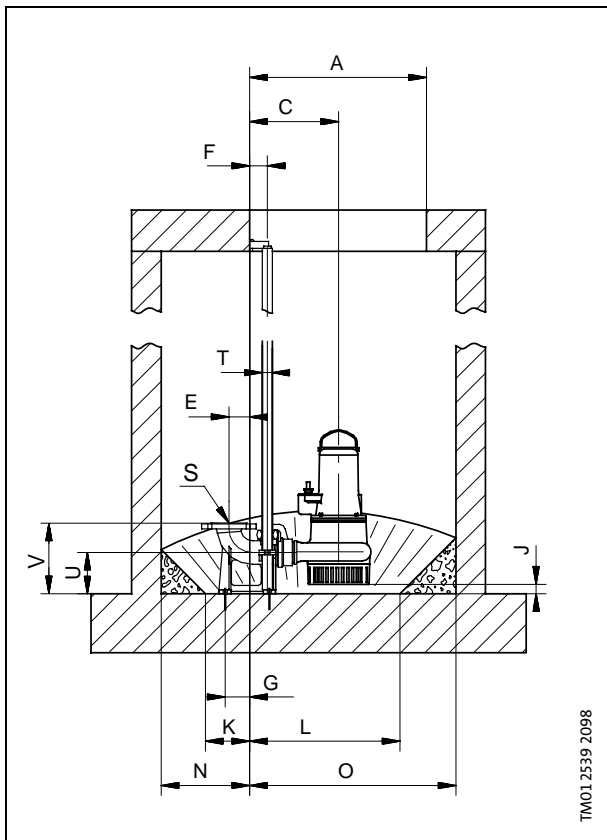

### One-pump installation on auto-coupling

Pump type	A	B	C	D	E	F	G	I	J	K	L	M	N	O	P	S	T	U	V
AP10.50.12.Ex	ø600	ø600	245	300	45	45	65	115	74	150	450	200	300	700	500	Rp 2	½"	160	295
AP10.65.21	ø600	ø600	300	297	70	60	82	180	32	150	510	220	350	650	500	DN65	1"	160	250

### Two-pump installation on auto-coupling

Pump type	A	B	C	D	E	F	G	I	J	K	L	M	N	O	P	R	S	T	U	V
AP10.50.12.Ex	445	600	245	135	45	45	65	115	74	150	450	200	300	700	335	330	Rp 2	½"	160	295
AP10.65.21	600	975	300	297	70	60	82	180	32	150	510	220	375	875	435	380	DN65	1"	160	250

## AP12



TM005738 0895

The AP12 pump is a single-stage submersible pump designed for the pumping of drainage water. The pump is suitable for the following applications

- ground water lowering,
- pumping in drainage pits,
- pumping in surface water pits with inflow from roof gutters, shafts, tunnels, etc.,
- emptying of ponds, tanks, etc. and
- maximum particle size: 12 mm.

### Approvals

PA-I no. 4104 VDE.

### Automatic operation

The pump is available for automatic as well as manual operation and can be installed in a permanent installation or used as a portable pump. The pump is available:

- with level switch fitted for automatic ON/OFF operation between two liquid levels (single-phase pumps);
- with separate level switch and control box for automatic ON/OFF operation between two liquid levels (three-phase pumps);
- without level switch for manual ON/OFF operation.

Pumps fitted with level switches can also be used for manual ON/OFF operation. In this case the level switch must be secured in an upwards-pointing position.

### Pump sleeve and housing

The stainless steel pump sleeve is made in one piece and equipped with an insulated carrying handle. The suction strainer is clipped on to the pump housing and can easily be removed for maintenance. The strainer not only prevents the passage of large solids but also ensures a slow flow into the pump. As a result, most impurities will be deposited outside the pump.

The stainless steel pump housing is fitted with an internal riser pipe ensuring high efficiency.

The riser pipe has a number of holes which enable efficient cooling of the motor during operation. The cable entry is of the socket and plug connection type, which makes quick and easy dismantling possible.

### Discharge port

All AP12 pumps have a threaded vertical discharge port.

AP12.40: Rp 1½.

AP12.50: Rp 2.

### Shaft and bearings

The shaft is made of stainless steel and rotates in maintenance-free prelubricated ball bearings.

### Impeller

The stainless steel impeller is a semi-open impeller with L-shaped blades and a clearance of 12 mm. The blades are curved backwards to reduce any harmful effect from solid particles and to reduce the power consumption.

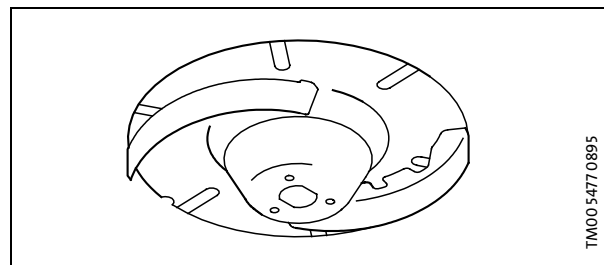

TM005477 0895

### Shaft seal

The shaft seal is a combination of a mechanical shaft seal of the bellows type and a lip seal with 60 ml oil between them. The mechanical shaft seal of AP12 pumps has silicone carbide seal faces.

### Motor cable

Standard pumps 10 m: H07RNF.

### Materials

Description	Materials	DIN W.-Nr.	AISI
Pump housing	Stainless steel	1.4301	304
Riser pipe	Stainless steel	1.4301	304
Impeller	Stainless steel	1.4301	304
Pump sleeve	Stainless steel	1.4401	316
Shaft	Stainless steel	1.4305	
Bearings	Heavy-duty prelubricated ball bearings		
O-rings	NBR rubber		
Screws	Stainless steel	1.4301	304
Oil	Shell Ondina 15, non-toxic		

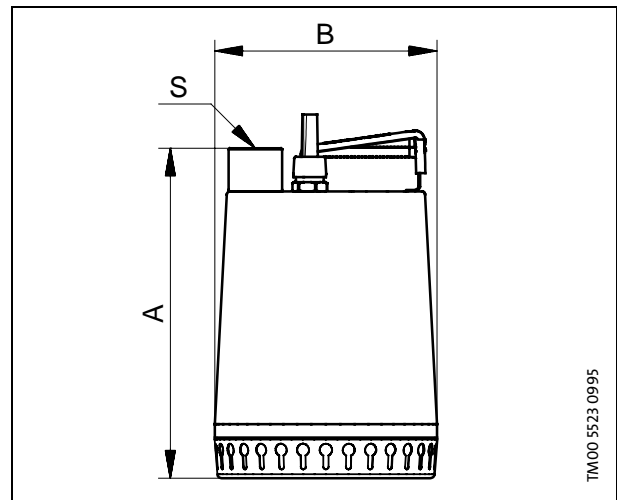
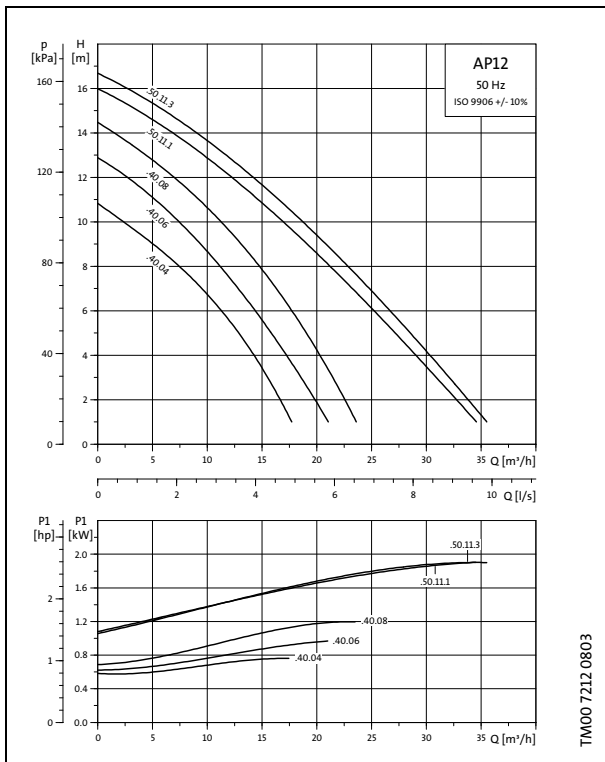

Pump type	Voltage	P <sub>1</sub> [kW]	P <sub>2</sub> [kW]	I <sub>n</sub> [A]	Cos φ	I <sub>start</sub> / I <sub>n</sub>	Dimensions [mm]			Weight [kg]
							A	B	S	
AP12.40.04.1	1 x 230 V	0.8	0.4	3.0	0.99	3.8	321	216	Rp 1½	11.0
AP12.40.04.A1	1 x 230 V	0.8	0.4	3.0	0.99	3.8	321	216	Rp 1½	11.0
AP12.40.04.3	3 x 230 V	0.8	0.4	2.2	0.85	4.7	321	216	Rp 1½	9.7
AP12.40.04.A.3	3 x 230 V	0.8	0.4	2.2	0.85	4.7	321	216	Rp 1½	12.0
AP12.40.04.3	3 x 400 V	0.8	0.4	1.2	0.83	5.0	321	216	Rp 1½	9.7
AP12.40.04.A.3	3 x 400 V	0.8	0.4	1.2	0.83	5.0	321	216	Rp 1½	12.0
AP12.40.06.1	1 x 230 V	1.0	0.6	4.4	0.99	3.8	321	216	Rp 1½	11.0
AP12.40.06.A.1	1 x 230 V	1.0	0.6	4.4	0.99	3.8	321	216	Rp 1½	11.0
AP12.40.06.3	3 x 230 V	1.0	0.6	2.9	0.83	5.4	321	216	Rp 1½	10.7
AP12.40.06.A.3	3 x 230 V	1.0	0.6	2.9	0.83	5.4	321	216	Rp 1½	13.0
AP12.40.06.3	3 x 400 V	1.0	0.6	1.6	0.83	4.8	321	216	Rp 1½	10.7
AP12.40.06.A.3	3 x 400 V	1.0	0.6	1.6	0.83	4.8	321	216	Rp 1½	10.7
AP12.40.08.1	1 x 230 V	1.3	0.8	5.9	0.99	3.8	346	216	Rp 1½	12.6
AP12.40.08.A.1	1 x 230 V	1.3	0.8	5.9	0.99	3.8	346	216	Rp 1½	12.6
AP12.40.08.3	3 x 230 V	1.2	0.8	3.7	0.85	4.7	346	216	Rp 1½	12.0
AP12.40.08.A.3	3 x 230 V	1.2	0.8	3.7	0.85	4.7	346	216	Rp 1½	14.3
AP12.40.08.3	3 x 400 V	1.2	0.8	2.1	0.87	4.9	346	216	Rp 1½	12.0
AP12.40.08.A.3	3 x 400 V	1.2	0.8	2.1	0.87	4.9	346	216	Rp 1½	14.3
AP12.50.11.1	1 x 230 V	1.9	1.1	8.5	0.92	3.8	357	241	Rp 2	15.1
AP12.50.11.A.1	1 x 230 V	1.9	1.1	8.5	0.92	3.8	357	241	Rp 2	15.1
AP12.50.11.3	3 x 230 V	1.9	1.1	6.4	0.85	3.6	357	241	Rp 2	15.6
AP12.50.11.A.3	3 x 230 V	1.9	1.1	6.4	0.85	3.6	357	241	Rp 2	17.9
AP12.50.11.3	3 x 400 V	1.9	1.1	3.2	0.88	4.6	357	241	Rp 2	15.6
AP12.50.11.A.3	3 x 400 V	1.9	1.1	3.2	0.88	4.6	357	241	Rp 2	17.9

## AP12 installations

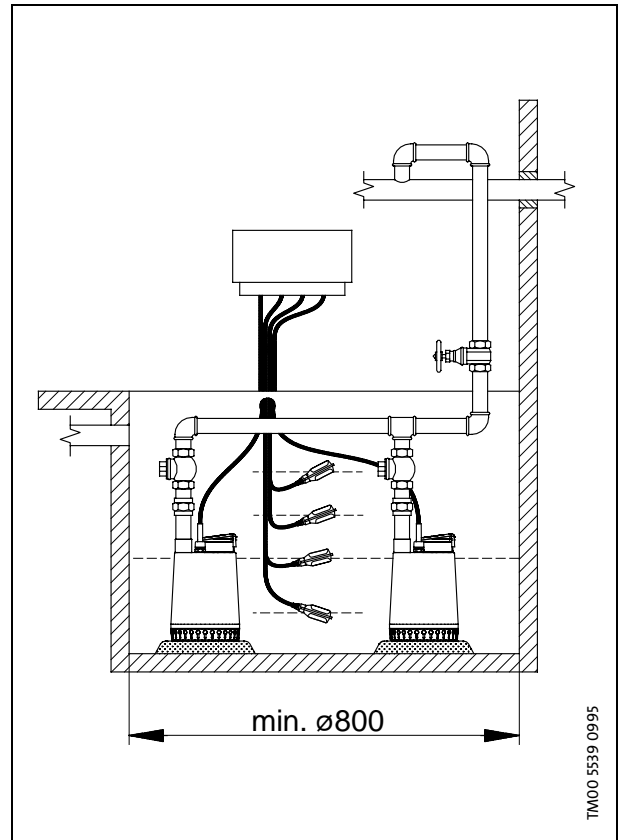
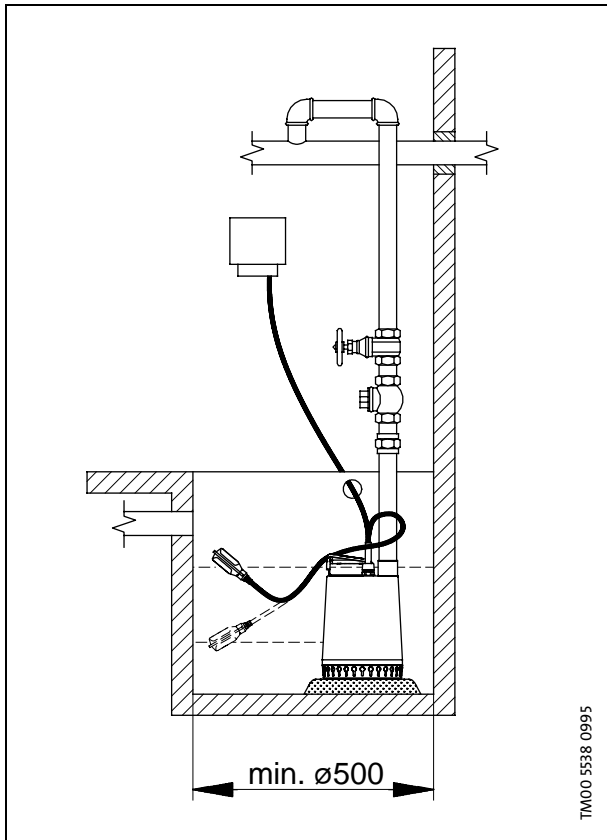



## AP30



The pumps are used for pumping wastewater, sludge-containing water, ground water and surface water in places such as

- holiday homes,
- single-family houses,
- blocks of flats,
- public buildings,
- factories,
- garages,
- underground car parks and
- car wash areas.

Applications as under AP10, but where a larger impeller clearance is required.

### Pump and stator housing

The pump housing and the stator housing are made of cast iron.

The stator housing is dry, i.e. not oil-filled.

### Discharge

All AP30 pumps have a horizontal R 2 discharge port for threaded connection.

### Shaft and bearings

The shaft is made of stainless steel and rotates in maintenance-free prelubricated ball bearings.

## Impeller

The impeller is an open single-vane cast iron impeller with a clearance of 30 mm. Cast iron is chosen as it is resistant towards mechanically wearing particles.

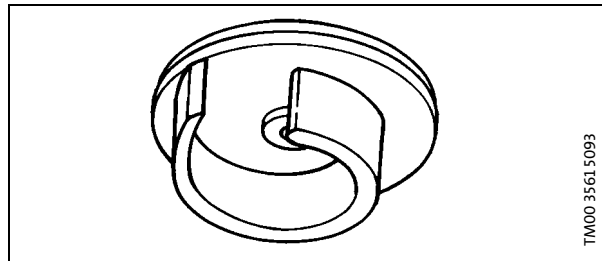

An adjustable cast iron wear plate is fitted at the inlet side of the impeller.

### Shaft seal

Combination of mechanical shaft seal and lip seal.

The primary shaft seal have silicon carbide/silicon carbide seal faces.

The secondary shaft seal is a lip seal. The chamber between the shaft seals is filled with oil.

Standard pumps: 0.01 litre  
Ex-pumps: 0.4 litre.

### Motor cable

Standard pumps 10 m: H07RNF.  
Ex-pumps 10 m: H07RNF - PLUS.

### Materials

Description	Materials	DIN W.-Nr.	AISI/ASTM
Stator housing	Cast iron EN-GJL-250	0.6025	ASTM 35B
Pump housing	Cast iron EN-GJL-250	0.6025	ASTM 35B
Neck ring	Bronze		
Impeller	Cast iron EN-GJL-250	0.6025	ASTM 35B
Wear plate	Cast iron EN-GJL-250	0.6025	ASTM 35B
Shaft	Stainless steel	1.4104	AISI 430F
Bearings	Heavy-duty prelubricated ball bearings		
Screws	Stainless steel	1.4301	AISI 304
Oil	Shell Ondina 15, non-toxic		

### Control box

Further information about control box, float switch, and level control, see page 44.

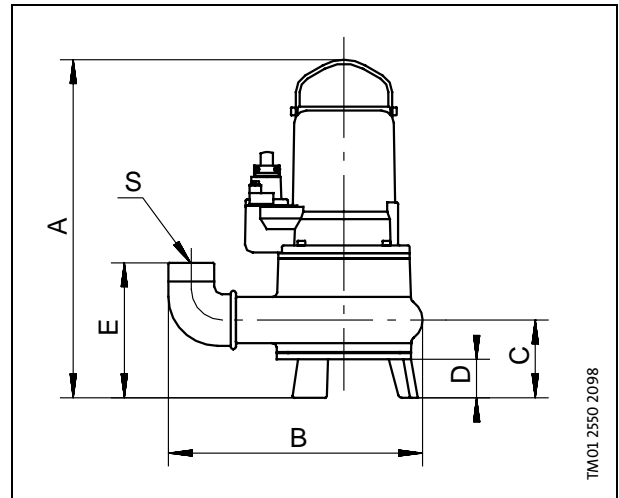
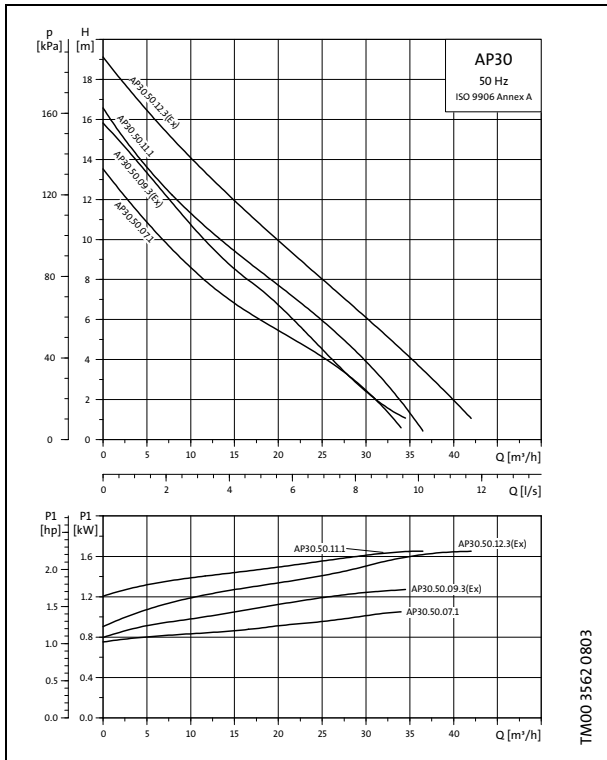

Elbow is an accessory.

Pump type	Voltage	P <sub>1</sub> [kW]	P <sub>2</sub> [kW]	n [min <sup>-1</sup> ]	I <sub>n</sub> [A]	Cos φ	I <sub>start</sub> I <sub>n</sub>	Dimensions [mm]						Weight [kg]
								A	B	C	D	E	S	
AP30.50.07.1	1 x 230 V	1.1	0.7	2850	4.3	1.00	3.4	390	312	95	45	169	R 2	24
AP30.50.07.A.1	1 x 230 V	1.1	0.7	2850	4.3	1.00	3.4	390	312	95	45	169	R 2	24
AP30.50.09.3	3 x 230 V	1.3	0.9	2850	3.9	0.83	4.5	390	312	95	45	169	R 2	24
AP30.50.09.A.3	3 x 230 V	1.3	0.9	2850	3.9	0.83	4.5	390	312	95	45	169	R 2	24
AP30.50.09.3	3 x 400 V	1.3	0.9	2850	2.2	0.83	4.4	390	312	95	45	169	R 2	24
AP30.50.09.A.3	3 x 400 V	1.3	0.9	2850	2.2	0.83	4.4	390	312	95	45	169	R 2	24
AP30.50.09.3.Ex	3 x 400 V	1.2	0.9	2850	2.2	0.83	4.4	578	353	111	61	185	R 2	29
AP30.50.11.1	1 x 230 V	1.7	1.1	2850	7.4	1.00	3.0	390	312	95	45	169	R 2	25
AP30.50.11.A.1	1 x 230 V	1.7	1.1	2850	7.4	1.00	3.0	390	312	95	45	169	R 2	25
AP30.50.12.3	3 x 230 V	1.7	1.2	2900	5.1	0.84	4.7	578	312	95	45	169	R 2	25
AP30.50.12.A.3	3 x 230 V	1.7	1.2	2900	5.1	0.84	4.7	578	312	95	45	169	R 2	25
AP30.50.12.3	3 x 400 V	1.7	1.2	2900	2.9	0.84	4.6	578	312	95	45	169	R 2	25
AP30.50.12.A.3	3 x 400 V	1.7	1.2	2900	2.9	0.84	4.6	578	312	95	45	169	R 2	25
AP30.50.12.3.Ex	3 x 400 V	1.7	1.2	2900	2.9	0.84	4.6	578	353	111	61	185	R 2	30

## AP30 installations

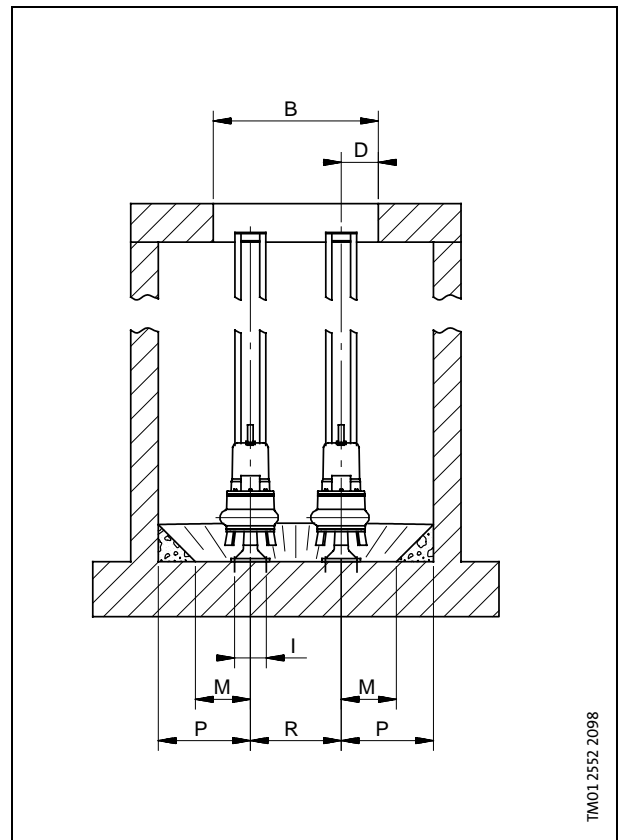
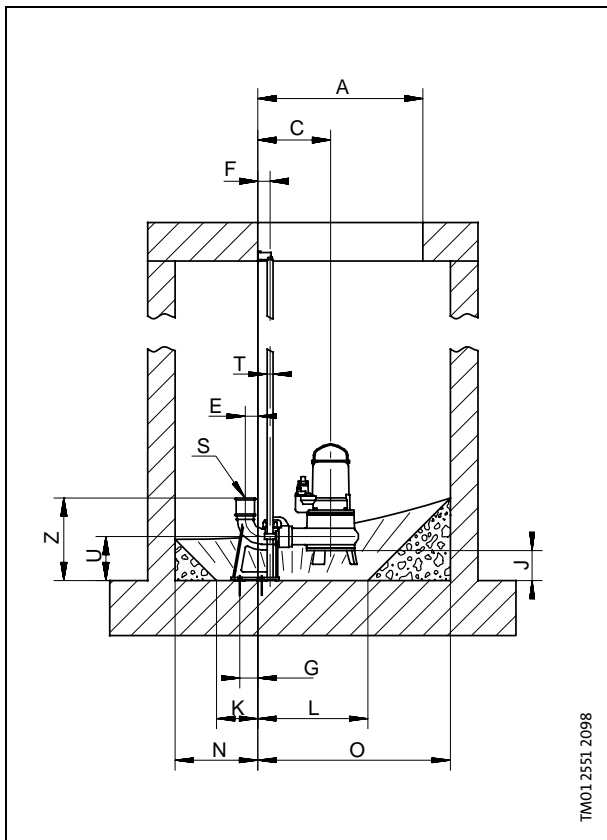

### One-pump installation on auto-coupling

Pump type	A	B	C	D	E	F	G	I	J	K	L	M	N	O	P	S	T	U	Z
AP30.50.07	ø600	ø600	245	300	45	45	65	115	112	150	400	200	300	700	500	Rp 2	½"	160	295
AP30.50.09	ø600	ø600	245	300	45	45	65	115	112	150	400	200	300	700	500	Rp 2	½"	160	295
AP30.50.09.Ex	ø600	ø600	245	300	45	45	65	115	112	150	400	200	300	700	500	Rp 2	½"	160	295
AP30.50.11	ø600	ø600	245	300	45	45	65	115	112	150	400	200	300	700	500	Rp 2	½"	160	295
AP30.50.12	ø600	ø600	245	300	45	45	65	115	112	150	400	200	300	700	500	Rp 2	½"	160	295
AP30.50.12.Ex	ø600	ø600	245	300	45	45	65	115	112	150	400	200	300	700	500	Rp 2	½"	160	295

### Two-pump installation on auto-coupling

Pump type	A	B	C	D	E	F	G	I	J	K	L	M	N	O	P	R	S	T	U	Z
AP30.50.07	455	600	245	135	45	45	65	115	112	150	400	200	300	700	335	330	Rp 2	½"	160	295
AP30.50.09	455	600	245	135	45	45	65	115	112	150	400	200	300	700	335	330	Rp 2	½"	160	295
AP30.50.09.Ex	455	600	245	135	45	45	65	115	112	150	400	200	300	700	335	330	Rp 2	½"	160	295
AP30.50.11	455	600	245	135	45	45	65	115	112	150	400	200	300	700	335	330	Rp 2	½"	160	295
AP30.50.12	455	600	245	135	45	45	65	115	112	150	400	200	300	700	335	330	Rp 2	½"	160	295
AP30.50.12.Ex	455	600	245	135	45	45	65	115	112	150	400	200	300	700	335	330	Rp 2	½"	160	295

## AP35



TM00 5739 1195

The AP35 pump is a single-stage submersible pump designed for the pumping of drainage water and effluent.

The pump is suitable for the following applications

- ground water lowering,
- pumping in drainage pits,
- pumping in surface water pits with inflow from roof gutters, shafts, tunnels, etc.,
- emptying of ponds, tanks, etc.,
- pumping of fibre-containing wastewater from laundries and industries and
- pumping of domestic wastewater without discharge from water closets.

## Approvals

PA-I no. 4104 VDE.

## Automatic operation

The pump is available for automatic as well as manual operation and can be installed in a permanent installation or used as a portable pump. The pump is available:

- with level switch fitted for automatic ON/OFF operation between two liquid levels (single-phase pumps);
- with separate level switch and control box for automatic ON/OFF operation between two liquid levels (three-phase pumps);
- without level switch for manual ON/OFF operation.

Pumps fitted with level switches can also be used for manual ON/OFF operation. In this case the level switch must be secured in an upwards-pointing position.

## Pump sleeve and housing

The stainless steel pump sleeve is made in one piece and equipped with an insulated carrying handle. The suction strainer is clipped on to the pump housing and can easily be removed for maintenance.

The strainer not only prevents the passage of large solids but also ensures a slow flow into the pump.

The stainless steel pump housing is fitted with an internal riser pipe ensuring high efficiency. The riser pipe has a number of holes which enable efficient cooling of the motor during operation. The cable entry is of the socket and plug connection type, which makes quick and easy dismantling possible.

## Discharge port

All AP35 pumps have a threaded vertical discharge port: Rp 1½.

## Shaft and bearings

The shaft is made of stainless steel and rotates in maintenance-free prelubricated ball bearings.

## Impeller

The stainless steel impeller is a Vortex impeller with L-shaped blades and a clearance of 35 mm (in the pump housing). The blades are curved backwards to reduce any harmful effect from solid particles and to reduce the power consumption. The impeller has a protective cap to prevent the deposits of long-fibred material.

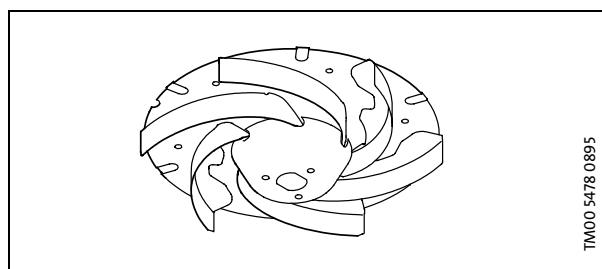

TM00 5478 0895

## Shaft seal

The shaft seal is a combination of a mechanical shaft seal of the bellows type and a lip seal with 60 ml oil faces.

## Motor cable

Standard pumps 10 m: H07RNF.

## Materials

Description	Materials	DIN W.-Nr.	AISI
Pump housing	Stainless steel	1.4301	304
Riser pipe	Stainless steel	1.4301	304
Impeller	Stainless steel	1.4301	304
Pump sleeve	Stainless steel	1.4401	316
Shaft	Stainless steel	1.4305	
Bearings	Heavy-duty prelubricated ball bearings		
O-rings	NBR rubber		
Screws	Stainless steel	1.4301	304
Cables	Neoprene		
Oil	Shell Ondina 15, non-toxic		

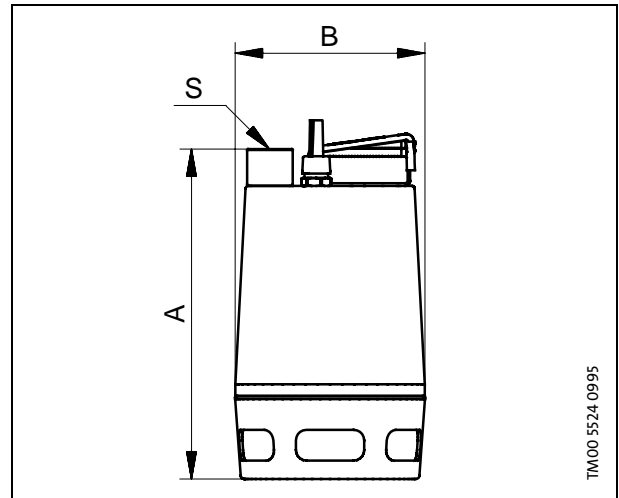
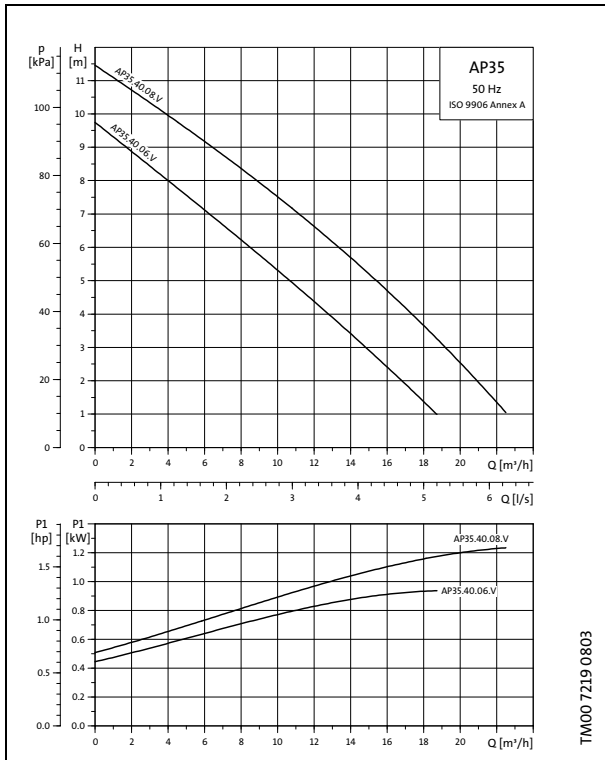

Pump type	Voltage	P <sub>1</sub> [kW]	P <sub>2</sub> [kW]	I <sub>n</sub> [A]	Cos φ	I <sub>start</sub> I <sub>n</sub>	Dimensions [mm]			Weight [kg]
							A	B	S	
AP35.40.06.1V	1 x 230 V	0.9	0.6	4.0	0.97	4.1	376	216	Rp 1½	11.4
AP35.40.06.A.1V	1 x 230 V	0.9	0.6	4.0	0.97	4.1	376	216	Rp 1½	11.4
AP35.40.06.3.V	3 x 230 V	1.0	0.6	3.0	0.85	5.2	376	216	Rp 1½	11.1
AP35.40.06.A.3.V	3 x 230 V	1.0	0.6	3.0	0.85	5.2	376	216	Rp 1½	13.4
AP35.40.06.3.V	3 x 400 V	0.9	0.6	1.6	0.83	4.8	376	216	Rp 1½	11.1
AP35.40.06.A.3.V	3 x 400 V	0.9	0.6	1.6	0.83	4.8	376	216	Rp 1½	13.4
AP35.40.08.1V	1 x 230 V	1.2	0.8	5.5	0.98	4.0	410	216	Rp 1½	12.7
AP35.40.08.A.1V	1 x 230 V	1.2	0.8	5.5	0.98	4.0	410	216	Rp 1½	12.7
AP35.40.08.3.V	3 x 230 V	1.3	0.8	3.6	0.85	5.3	410	216	Rp 1½	12.1
AP35.40.08.A.3.V	3 x 230 V	1.3	0.8	3.6	0.85	5.3	410	216	Rp 1½	14.4
AP35.40.08.3.V	3 x 400 V	1.1	0.8	2.0	0.86	5.1	410	216	Rp 1½	12.1
AP35.40.08.A.3.V	3 x 400 V	1.1	0.8	2.0	0.86	5.1	410	216	Rp 1½	14.4

## AP35 installations

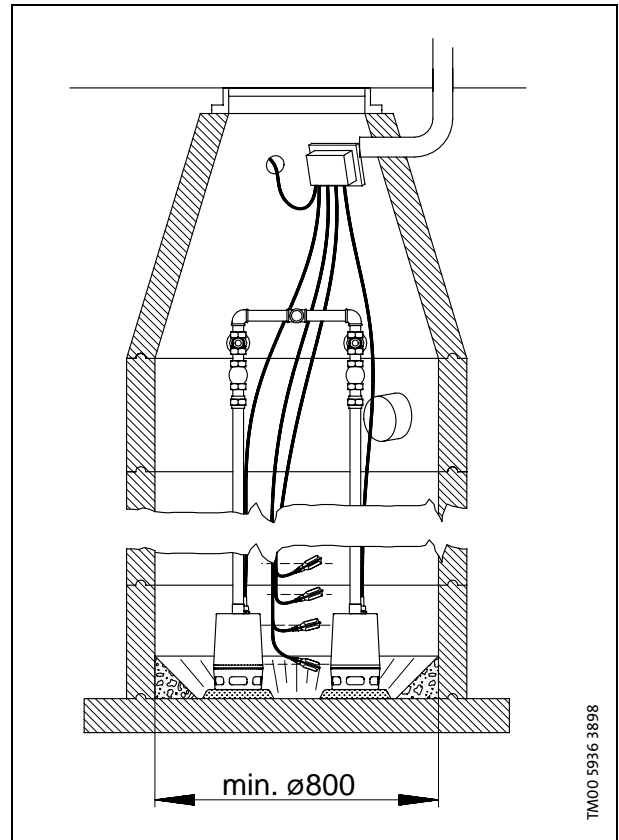
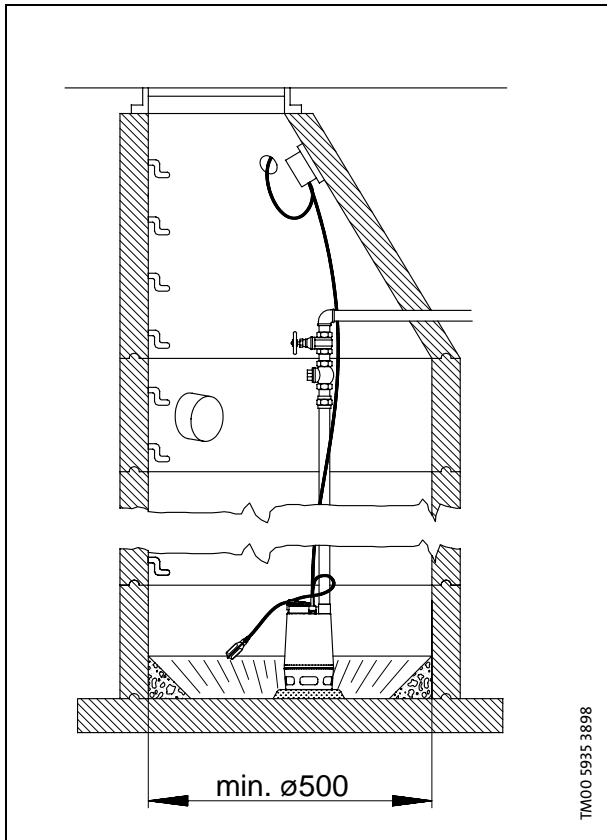

## AP35B



The AP35B pump is a single-stage submersible pump designed for pumping effluent.

The pump is suitable for:

- groundwater lowering,
- pumping in drainage pits,
- pumping in surface water pits with inflow from roof gutters, shafts, tunnels, etc.,
- emptying of ponds, tanks, etc.,
- pumping of fibre-containing effluent from laundries and industries,
- pumping of domestic effluent from septic tanks and sludge treating systems,
- pumping of domestic effluent without discharge from water closets

## Automatic operation

The pump is available for automatic as well as manual operation and can be installed in a permanent installation or used as a portable pump.

The pump is available:

- with level switch fitted for automatic ON/OFF operation between two liquid levels (single-phase pumps);
- without level switch for manual ON/OFF operation.

Pumps fitted with level switches can also be used for manual ON/OFF operation. In this case the level switch must be secured in an upwards-pointing position.

## Pump housing

Pump housing with an outstanding design for submersible wastewater pumps resulting in a high head.

The pump housing is made of a steel tube with a smooth surface and a hydraulically correct shape ensuring free passage of particles.

Base, pump inlet and pump housing are fastened to the motor by means of 4 springs enabling quick and easy dismantling.

## Discharge port

All AP35B pumps have a threaded horizontal discharge port: Rp 2.

## Shaft and bearings

The shaft is made of stainless steel and rotates in maintenance-free prelubricated ball bearings.

## Impeller

The stainless steel impeller is a Vortex impeller with L-shaped blades and a clearance of 35 mm (in the pump housing). The blades are curved backwards to reduce any harmful effect from solid particles and to reduce the power consumption. The impeller has a protective cap to prevent the deposits of long-fibred material.

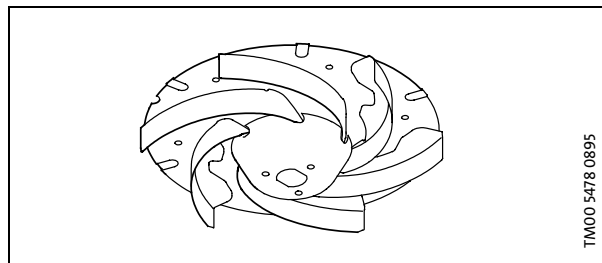

## Shaft seal

The shaft seal is a combination of a mechanical shaft seal of the bellows type and a lip seal with 80 ml oil between them. The shaft seal has silicon carbide seal faces.

## Materials

Description	Materials	DIN W.-Nr.	AISI
Pump housing	Stainless steel	1.4301	304
Impeller	Stainless steel	1.4301	304
Washer	Stainless steel	1.4301	304
Protective cap	Novolen 2360 Kx		
Motor unit complete	Parts in contact with liquid: Stainless steel	1.4401	316
Shaft with rotor	Stainless steel/silumin	1.4305	
Motor cable	Neoprene		
O-rings	NBR rubber		
Spring	Stainless steel	1.4310	
Pump inlet	Stainless steel	1.4301	304
Base	Polycarbonate		
Oil	Shell Ondina 15, non-toxic		

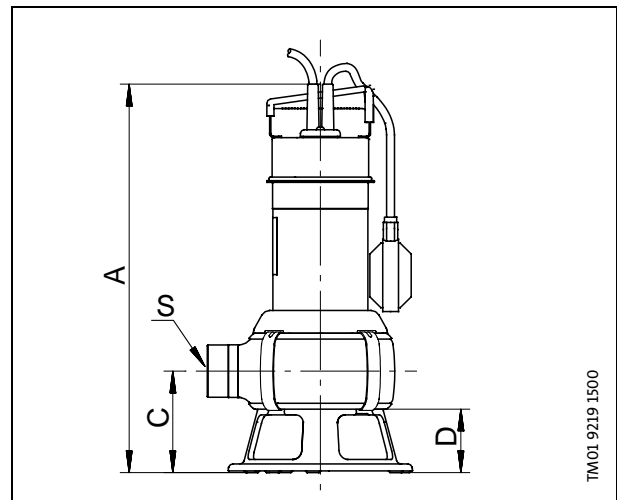
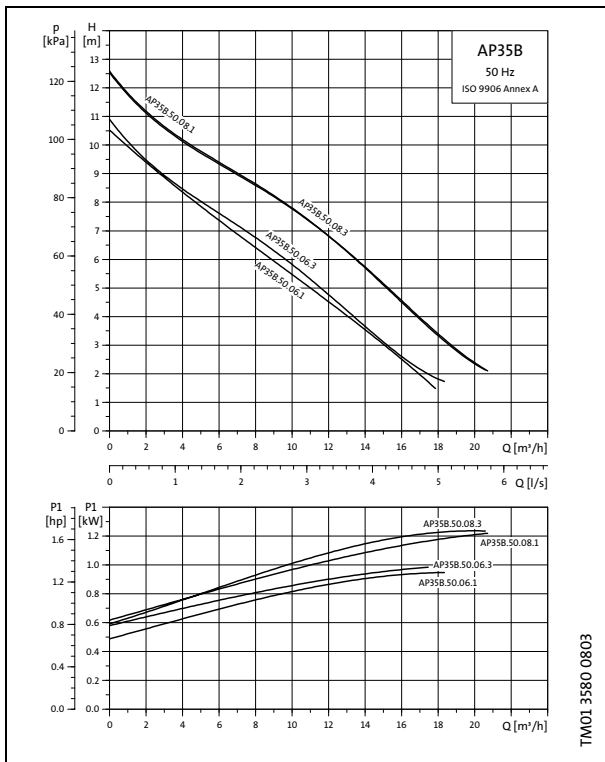

Pump type	Voltage	P <sub>1</sub> [kW]	P <sub>2</sub> [kW]	I <sub>n</sub> [A]	Cos φ	C [μF]	I <sub>start</sub> I <sub>n</sub>	Dimensions [mm]				Weight [kg]	Cable length/ -type
								A	C	D	S		
AP35B.50.06.A1.V	1 x 230 V	0.99	0.6	4.4	0.98	3.1	13.8	443	116	73	R 2	8.5	5 m with Schuko plug
AP35B.50.06.1.V	1 x 230 V	0.99	0.6	4.4	0.98	3.1	13.8	443	116	73	R 2	8.5	10 m with Schuko plug
AP35B.50.06.3.V	3 x 400 V	0.95	0.6	1.55	0.89	5.2	8.0	443	116	73	R 2	7.4	5 m without plug
AP35B.50.08.A1.V	1 x 230 V	1.22	0.8	5.44	0.98	3.4	18.4	468	116	73	R 2	10.0	5 m with Schuko plug
AP35B.50.08.1.V	1 x 230 V	1.22	0.8	5.44	0.98	3.4	18.4	468	116	73	R 2	10.0	10 m with Schuko plug
AP35B.50.08.3.V	3 x 400 V	1.23	0.8	1.98	0.89	5.4	10.6	468	116	73	R 2	8.4	5 m without stik



## AP35B installations

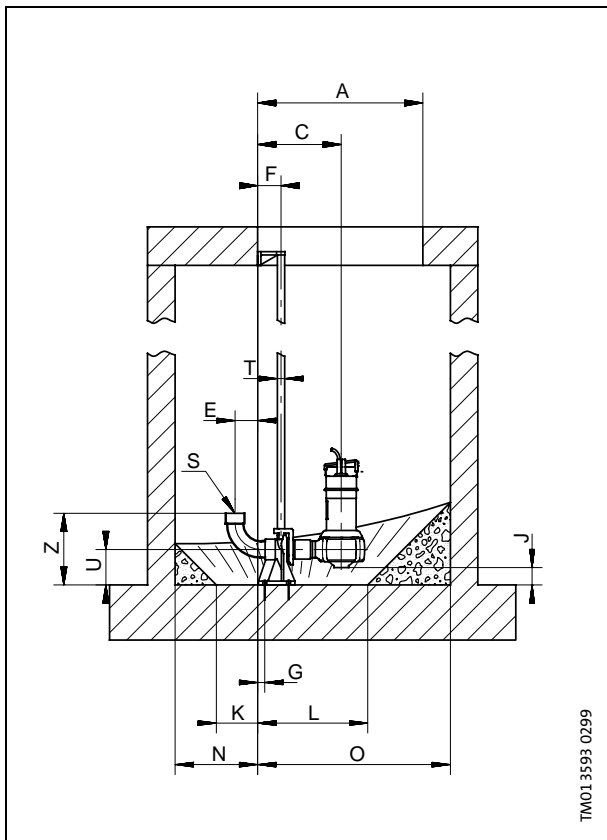

TM01 3593 0299

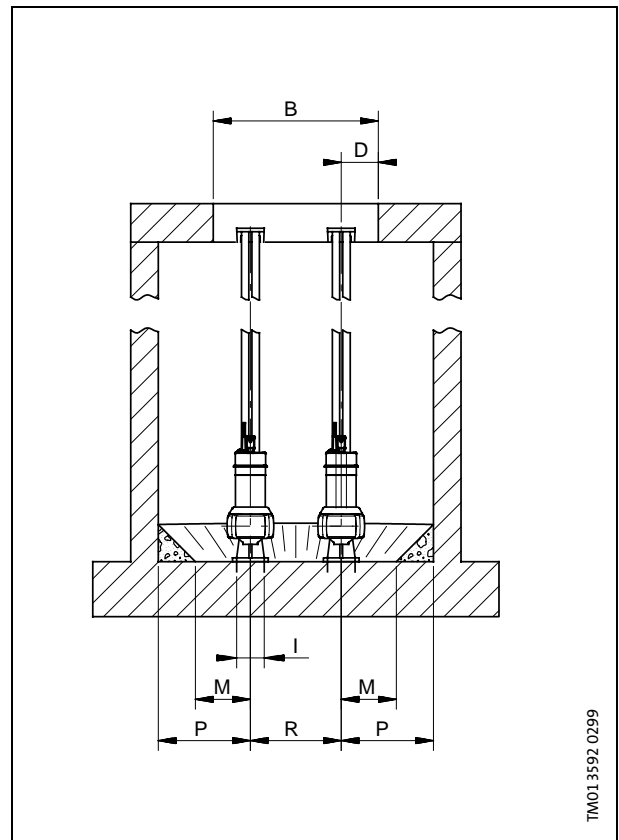

TM01 3592 0299

## One-pump installation on auto-coupling

Pump type	Dimensions [mm]																			
	A	B	C	D	E	F	G	I	J	K	L	M	N	O	P	R	S	T	U	Z
AP35B.50.06	ø600	ø600	304	135	82	85	65	100	76	150	400	200	300	700	500	-	R 2	¼"	130	261
AP35B.50.08	ø600	ø600	304	135	82	85	65	100	76	150	400	200	300	700	500	-	R 2	¼"	130	261

## Two-pump installation on auto-coupling

Pump type	Dimensions [mm]																			
	A	B	C	D	E	F	G	I	J	K	L	M	N	O	P	R	S	T	U	Z
AP35B.50.06	600	600	304	135	82	85	26	100	76	150	400	200	300	700	335	330	R 2	¼"	130	261
AP35B.50.08	600	600	304	135	82	85	26	100	76	150	400	200	300	700	35	330	R 2	¼"	130	261

## AP50



TM00 5740 1495

The AP50 pump is a single-stage submersible pump designed for the pumping of effluent and sewage. The pump is suitable for the following applications

- ground water lowering,
- pumping in drainage pits,
- pumping in surface water pits with inflow from roof gutters, shafts, tunnels, etc.,
- emptying of ponds, tanks, etc.,
- pumping of fibre-containing wastewater from laundries and industries,
- pumping of domestic wastewater from septic tanks and sludge treating systems and
- pumping of domestic wastewater with/without discharge from water closets.

### Approvals

PA-I no. 4104 and VDE.

### Automatic operation

The pump is available for automatic as well as manual operation and can be installed in a permanent installation or used as a portable pump. The pump is available:

- with level switch fitted for automatic ON/OFF operation between two liquid levels (single-phase pumps);
- with separate level switch and control box for automatic ON/OFF operation between two liquid levels (three-phase pumps);
- without level switch for manual ON/OFF operation

Pumps fitted with level switches can also be used for manual ON/OFF operation. In this case the level switch must be secured in an upwards-pointing position.

### Pump sleeve and housing

The stainless steel pump sleeve is made in one piece and equipped with an insulated carrying handle.

The suction strainer is clipped on to the pump housing and can easily be removed for maintenance. The strainer not only prevents the passage of large solids but also ensures a slow flow into the pump.

The stainless steel pump housing is fitted with an internal riser pipe ensuring high efficiency. The riser pipe has a number of holes which enable efficient cooling of the motor during operation. The cable entry is of the socket and plug connection type, which makes quick and easy dismantling possible.

### Discharge port

All AP50 pumps have a threaded vertical discharge port: Rp 2.

### Shaft and bearings

The shaft is made of stainless steel and rotates in maintenance-free prelubricated ball bearings.

### Impeller

The stainless steel impeller is a Vortex impeller with L-shaped blades and a clearance of 50 mm (in the pump housing). The blades are curved backwards to reduce any harmful effect from solid particles and to reduce the power consumption. The impeller has a protective cap to prevent the deposits of long-fibred material.

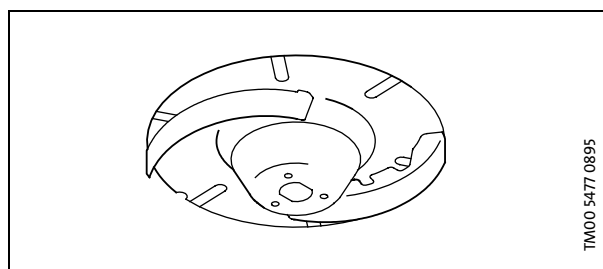

TM00 5477 0895

### Shaft seal

The shaft seal is a combination of a mechanical shaft seal of the bellows type and a lip seal with 60 ml oil between them. The shaft seal has silicon carbide seal faces.

### Motor cable

Standard pumps 10 m: H07RNF.

### Materials

Description	Materials	DIN W.-Nr.	AISI
Pump housing	Stainless steel	1.4301	304
Riser pipe	Stainless steel	1.4301	304
Impeller	Stainless steel	1.4301	304
Pump sleeve	Stainless steel	1.4401	316
Shaft	Stainless steel	1.4305	
Bearings	Heavy-duty prelubricated ball bearings		
O-rings	NBR rubber		
Screws	Stainless steel	1.4301	304
Cables	Neoprene		
Oil	Shell Ondina 15, non-toxic		

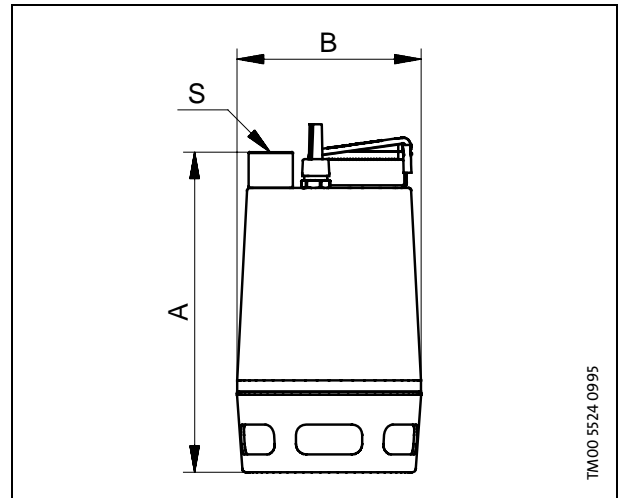
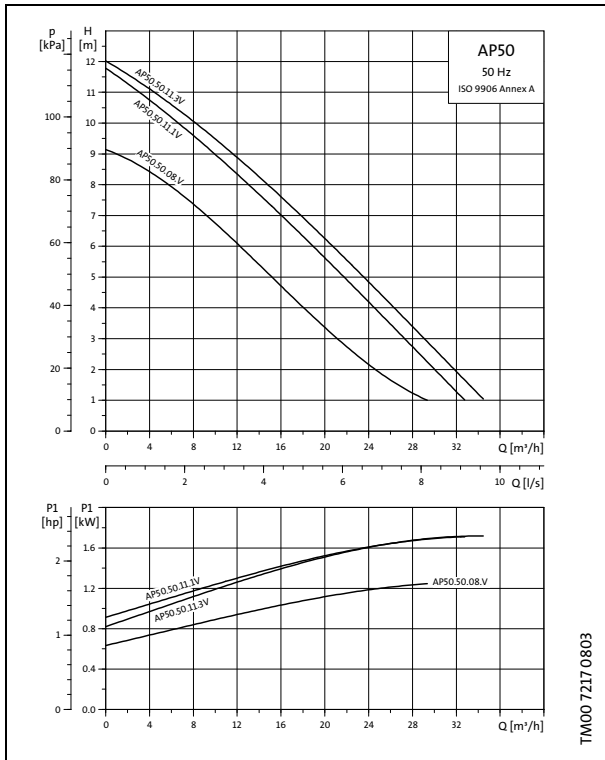

Pump type	Voltage	P <sub>1</sub> [kW]	P <sub>2</sub> [kW]	I <sub>n</sub> [A]	Cos φ	I <sub>start</sub> I <sub>n</sub>	Dimensions [mm]			Weight [kg]
							A	B	S	
AP50.50.08.1.V	1 x 230 V	1.3	0.8	5.9	0.99	1.9	436	241	Rp 2	15.1
AP50.50.08.A.1.V	1 x 230 V	1.3	0.8	5.9	0.99	1.9	436	241	Rp 2	15.1
AP50.50.08.3.V	3 x 230 V	1.2	0.8	3.3	0.85	2.8	436	241	Rp 2	14.2
AP50.50.08.A.3.V	3 x 230 V	1.2	0.8	3.3	0.85	2.8	436	241	Rp 2	16.5
AP50.50.08.3.V	3 x 400 V	1.2	0.8	2.0	0.80	3.0	436	241	Rp 2	14.2
AP50.50.08.A.3.V	3 x 400 V	1.2	0.8	2.0	0.80	3.0	436	241	Rp 2	16.5
AP50.50.11.1.V	1 x 230 V	1.8	1.1	8.0	0.92	4.0	436	241	Rp 2	15.1
AP50.50.11.A.1.V	1 x 230 V	1.8	1.1	8.0	0.92	4.0	436	241	Rp 2	15.1
AP50.50.11.3.V	3 x 230 V	1.8	1.1	6.0	0.85	2.8	436	241	Rp 2	15.6
AP50.50.11.A.3.V	3 x 230 V	1.8	1.1	6.0	0.85	2.8	436	241	Rp 2	17.9
AP50.50.11.3.V	3 x 400 V	1.8	1.1	3.0	0.88	4.9	436	241	Rp 2	15.6
AP50.50.11.A.3.V	3 x 400 V	1.8	1.1	3.0	0.88	4.9	436	241	Rp 2	17.9

## AP50 installations

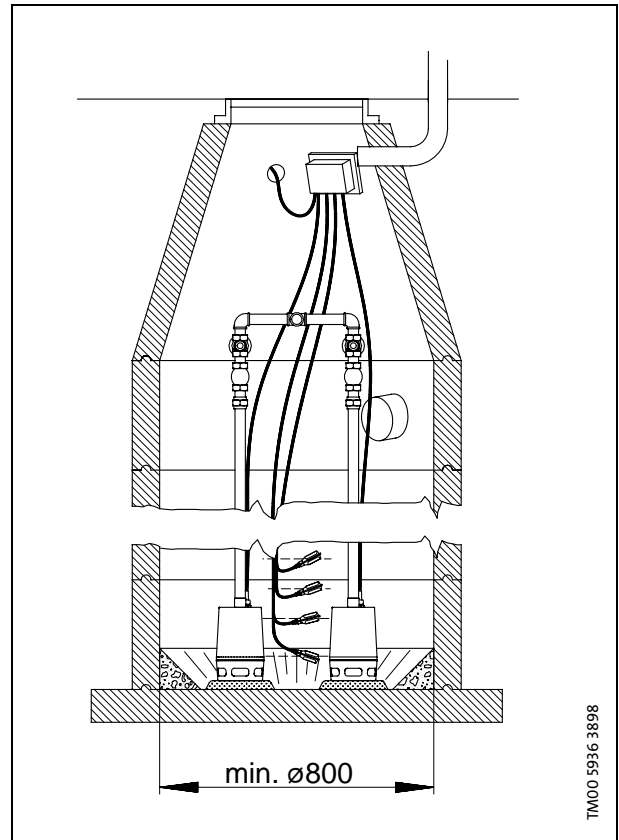
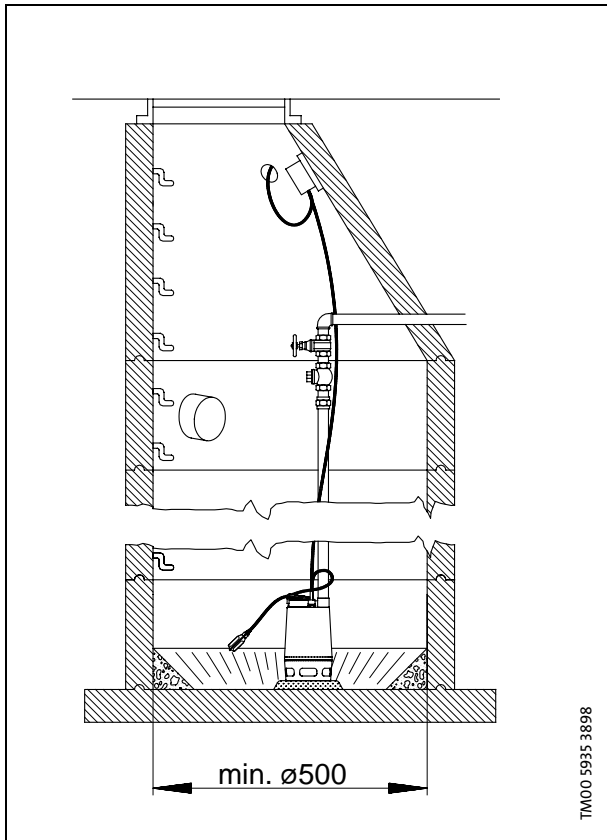

## AP50B



The AP50B pump is a single-stage submersible pump designed for pumping effluent.

The pump is suitable for:

- groundwater lowering,
- pumping in drainage pits,
- pumping in surface water pits with inflow from roof gutters, shafts, tunnels, etc.,
- emptying of ponds, tanks, etc.,
- pumping of fibre-containing effluent from laundries and industries,
- pumping of domestic effluent from septic tanks and sludge treating systems,
- pumping of domestic effluent without discharge from water closets,

## Automatic operation

The pump is available for automatic as well as manual operation and can be installed in a permanent installation or used as a portable pump.

The pump is available:

- with level switch fitted for automatic ON/OFF operation between two liquid levels (single-phase pumps);
- without level switch for manual ON/OFF operation.

Pumps fitted with level switches can also be used for manual ON/OFF operation. In this case the level switch must be secured in an upwards-pointing position.

## Pump housing

Pump housing with an outstanding design for submersible wastewater pumps resulting in a high head.

The pump housing is made of a steel tube with a smooth surface and a hydraulically correct shape ensuring free passage of particles.

Base, pump inlet and pump housing are fastened to the motor by means of 4 springs enabling quick and easy dismantling.

## Discharge port

All AP50B pumps have a threaded horizontal discharge port: R 2.

## Shaft and bearings

The shaft is made of stainless steel and rotates in maintenance-free prelubricated ball bearings.

## Impeller

The stainless steel impeller is a Vortex impeller with L-shaped blades and a clearance of 50 mm (in the pump housing). The blades are curved backwards to reduce any harmful effect from solid particles and to reduce the power consumption. The impeller has a protective cap to prevent the deposits of long-fibred material.

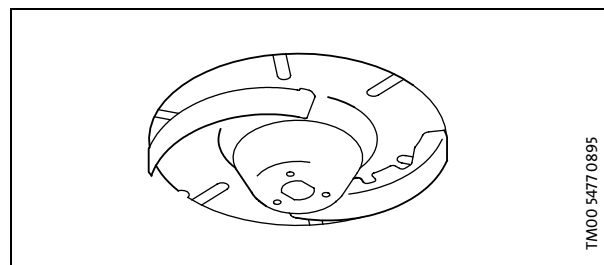

## Shaft seal

The shaft seal is a combination of a mechanical shaft seal of the bellows type and a lip seal with 80 ml oil between them. The shaft seal has silicon carbide seal faces.

## Materials

Description	Materials	DIN W.-Nr.	AISI
Pump housing	Stainless steel	1.4301	304
Impeller	Stainless steel	1.4301	304
Washer	Stainless steel	1.4301	304
Protective cap	Novolen 2360 Kx		
Motor unit complete	Parts in contact with liquid: Stainless steel	1.4401	316
Shaft with rotor	Stainless steel/silumin	1.4305	
Motor cable	Neoprene		
O-rings	NBR rubber		
Spring	Stainless steel	1.4310	
Pump inlet	Stainless steel	1.4301	304
Base	Polycarbonate		
Oil	Shell Ondina 15, non-toxic		

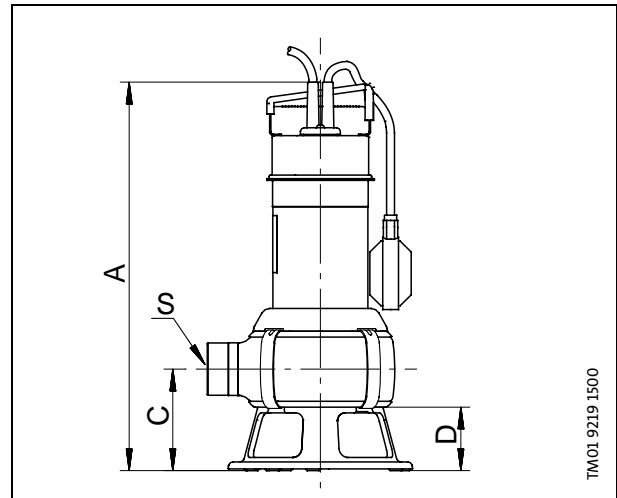
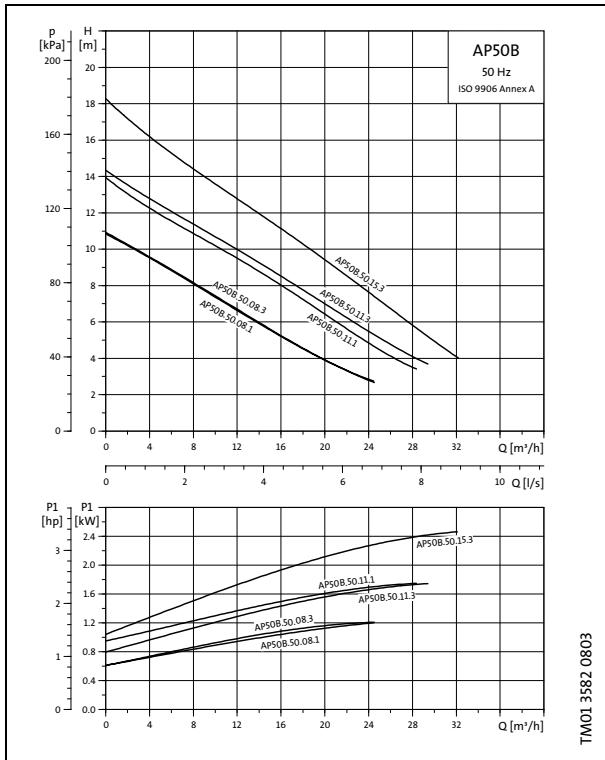

Pump type	Voltage	P <sub>1</sub> [kW]	P <sub>2</sub> [kW]	I <sub>n</sub> [A]	Cos φ	C [μF]	I <sub>start</sub> /I <sub>n</sub>	Dimensions [mm]				Weight [kg]	Cable length/-type
								A	C	D	S		
AP50B.50.08.A1.V	1 x 230 V	1.2	0.8	5.37	0.97	16	18.4	468	116	73	R 2	10.1	5 m with Schuko plug
AP50B.50.08.1.V	1 x 230 V	1.2	0.8	5.37	0.97	16	18.4	468	116	73	R 2	10.1	10 m with Schuko plug
AP50B.50.08.3.V	3 x 400 V	1.21	0.8	1.95	0.89		10.6	468	116	73	R 2	8.4	5 m without plug
AP50B.50.11.A1.V	1 x 230 V	1.75	1.1	8.00	0.95	16	23.8	468	116	73	R 2	10.2	5 m with Schuko plug
AP50B.50.11.1.V	1 x 230 V	1.75	1.1	8.00	0.95	16	23.8	468	116	73	R 2	10.2	10 m with Schuko plug
AP50B.50.11.3.V	3 x 400 V	1.75	1.1	2.81	0.90		16.0	468	116	73	R 2	9.7	5 m without plug
AP50B.50.15.3.V	3 x 400 V	2.15	1.5	3.00	0.88		22.4	468	116	73	R 2	10.0	5 m without plug

## AP50B installations

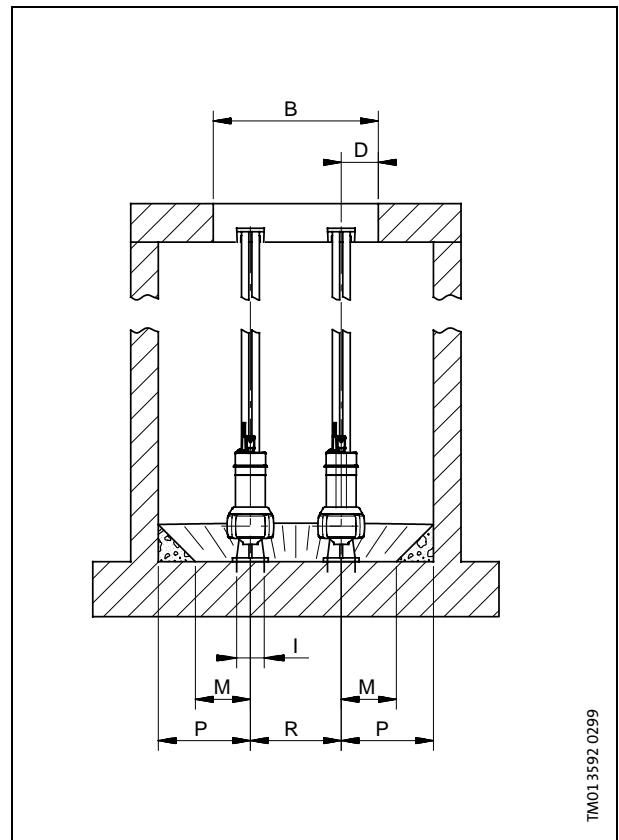
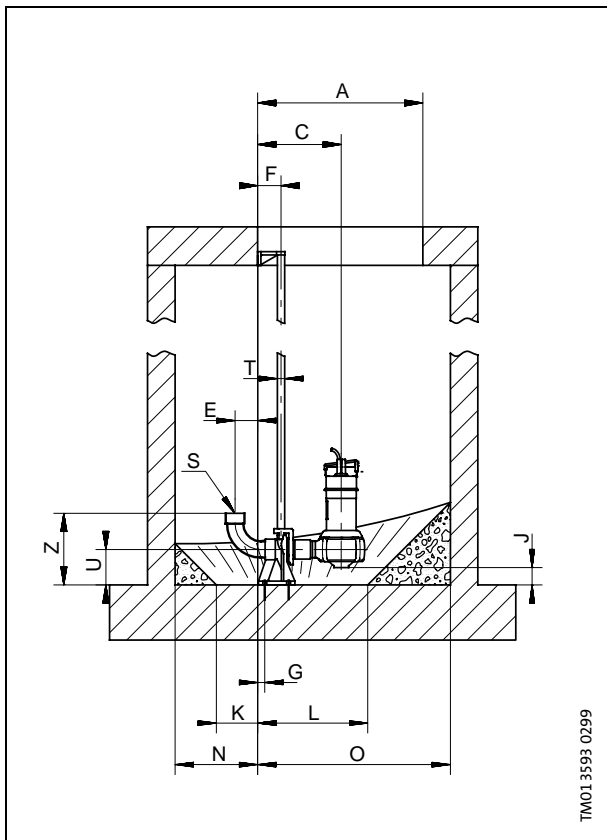

### One-pump installation on auto-coupling

Pump type	Dimensions [mm]																			
	A	B	C	D	E	F	G	I	J	K	L	M	N	O	P	R	S	T	U	Z
AP50B.50.08	ø600	ø600	304	135	82	85	65	100	76	150	400	200	300	700	500	-	R 2	¼"	130	261
AP50B.50.11	ø600	ø600	304	135	82	85	65	100	76	150	400	200	300	700	500	-	R 2	¼"	130	261
AP50B.50.15	ø600	ø600	304	135	82	85	65	100	76	150	400	200	300	700	500	-	R 2	¼"	130	261

### Two-pump installation on auto-coupling

Pump type	Dimensions [mm]																			
	A	B	C	D	E	F	G	I	J	K	L	M	N	O	P	R	S	T	U	Z
AP50B.50.08	600	600	304	135	82	85	26	100	76	150	400	200	300	700	335	330	R 2	¼"	130	261
AP50B.50.11	600	600	304	135	82	85	26	100	76	150	400	200	300	700	335	330	R 2	¼"	130	261
AP50B.50.15	600	600	304	135	82	85	26	100	76	150	400	200	300	700	335	330	R 2	¼"	130	261

## AP51



The pumps are used for pumping wastewater, sludge-containing water, considerable quantities of surface water and ground water in places such as

- holiday homes,
- public buildings,
- factories,
- garages,
- underground car parks and
- car wash areas.

If permitted by local laws or regulations, the AP51 pumps can be used for the pumping of sewage from single and multi-family houses.

### Pump and stator housing

The pump housing and the stator housing are made of cast iron.

The stator housing is dry, i.e. not oil-filled.

### Discharge

All AP51 pumps have a horizontal R 2½ discharge port for threaded connection.

### Shaft and bearings

The shaft is made of stainless steel and rotates in maintenance-free prelubricated ball bearings.

The lower bearing of AP51.65.17 and AP51.65.22 is a double-row ball bearing.

## Impeller

The impeller is a closed single-channel cast iron impeller with a clearance of 50 mm. Cast iron is chosen as it is resistant towards mechanically wearing particles.

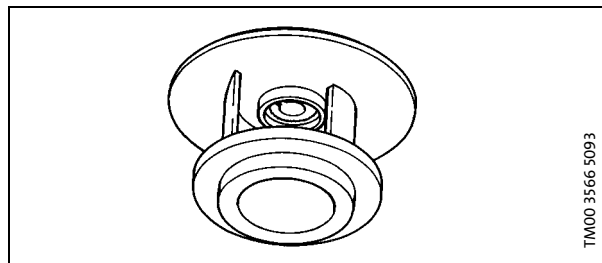

The inlet side of the pump housing is fitted with a replaceable neck ring.

## Shaft seal

AP51.65.07,  
AP51.65.12:

Combination of mechanical bellows seal and lip seal.

The primary shaft seal has silicon carbide/silicon carbide seal faces. The secondary shaft seal is a lip seal. The chamber between the shaft seals is filled with 0.01 litre of oil.

AP51.65.17,  
AP51.65.22 and  
Ex-pumps:

Two mechanical bellows seals, with silicon carbide/silicon carbide seal faces. The chamber between the primary and the secondary shaft seals is filled with 1.2 litre of oil.

## Motor cable

Standard pumps 10 m: H07RNF.

Ex-pumps 10 m: H07RNF - PLUS.

## Materials

Description	Materials	DIN W.-Nr.	AISI
Stator housing	Cast iron EN-GJL-250	0.6025	ASTM 35B
Pump housing	Cast iron EN-GJL-250	0.6025	ASTM 35B
Neck ring	Bronze		
Impeller	Cast iron EN-GJL-250	0.6025	ASTM 35B
Shaft	Stainless steel	1.4104	AISI 430F
Bearings	Heavy-duty prelubricated ball bearings		
Screws	Stainless steel	1.4301	AISI 304
Oil	Shell Ondina 15, non-toxic		

## Control box

Further information about control box, float switch, and level control, see page 44.



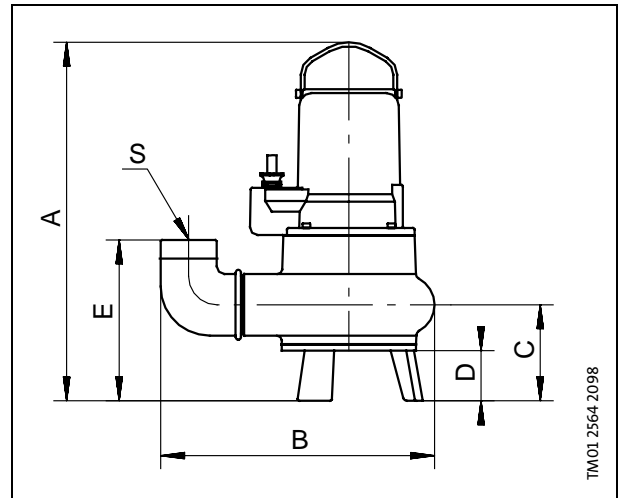
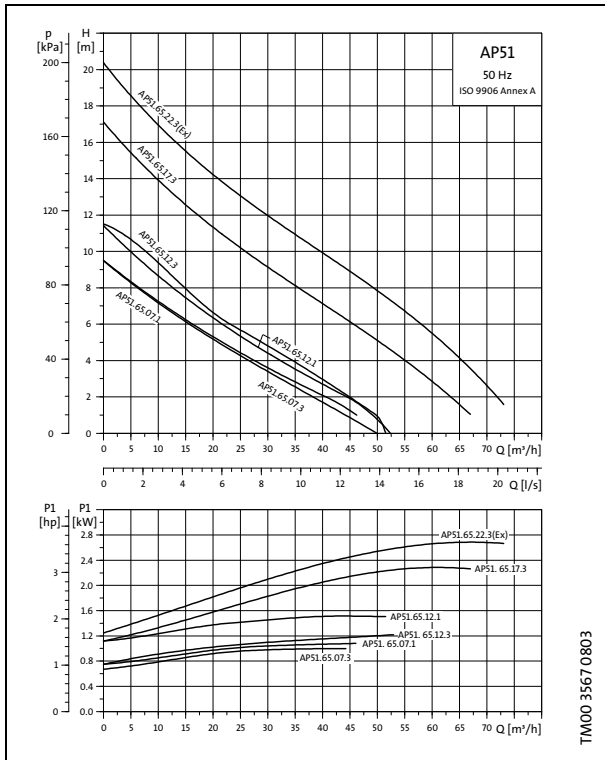

Elbow is an accessory.

Pump type	Voltage	P <sub>1</sub> [kW]	P <sub>2</sub> [kW]	n [min <sup>-1</sup> ]	I <sub>n</sub> [A]	Cos φ	I <sub>start</sub> I <sub>n</sub>	Dimensions [mm]						Weight [kg]
								A	B	C	D	E	S	
AP51.65.07.1	1 x 230 V	1.1	0.7	2900	5.9	1.00	2.5	465	350	110	55	198	R 2½	26
AP51.65.07.A.1	1 x 230V	1.1	0.7	2900	5.9	1.00	2.5	465	350	110	55	198	R 2½	26
AP51.65.07.3	3 x 230 V	1.0	0.7	2900	3.3	0.83	5.4	465	350	110	55	198	R 2½	26
AP51.65.07.A.3	3 x 230 V	1.0	0.7	2900	3.3	0.83	5.4	465	350	110	55	198	R 2½	26
AP51.65.07.3	3 x 400 V	1.0	0.7	2900	1.9	0.83	5.1	465	350	110	55	198	R 2½	26
AP51.65.07.A.3	3 x 400 V	1.0	0.7	2900	1.9	0.83	5.1	465	350	110	55	198	R 2½	26
AP51.65.12.1	1 x 230 V	1.6	1.2	2900	6.6	1.00	3.4	465	350	124	65	198	R 2½	27
AP51.65.12.A.1	1 x 230V	1.6	1.2	2900	6.6	1.00	3.4	465	350	124	65	198	R 2½	27
AP51.65.12.3	3 x 230 V	1.6	1.2	2900	4.0	0.83	5.9	645	350	124	65	198	R 2½	27
AP51.65.12.A.3	3 x 230 V	1.6	1.2	2900	4.0	0.83	5.9	645	350	124	65	198	R 2½	27
AP51.65.12.3	3 x 400 V	1.6	1.2	2900	2.3	0.83	5.8	645	350	124	65	198	R 2½	27
AP51.65.12.A.3	3 x 400 V	1.6	1.2	2900	2.3	0.83	5.8	645	350	124	65	198	R 2½	27
AP51.65.17.3	3 x 230 V	2.5	1.7	2900	6.6	0.80	5.4	518	368	101	50	187	R 2½	40
AP51.65.17.3	3 x 400 V	2.5	1.7	2900	3.8	0.80	5.3	518	368	101	50	187	R 2½	40
AP51.65.22.3	3 x 230 V	2.8	2.2	2900	8.2	0.82	4.4	518	368	101	50	185	R 2½	40
AP51.65.22.3	3 x 400 V	2.8	2.2	2900	4.7	0.82	4.3	518	368	101	50	185	R 2½	40
AP51.65.22.3.Ex	3 x 400 V	2.8	2.2	2900	4.7	0.82	4.3	518	368	101	50	185	R 2½	52
AP51.65.22.3.Ex	3 x 230 V	2.8	2.2	2900	8.2	0.82	4.4	518	368	101	50	185	R 2½	52

## AP51 installations

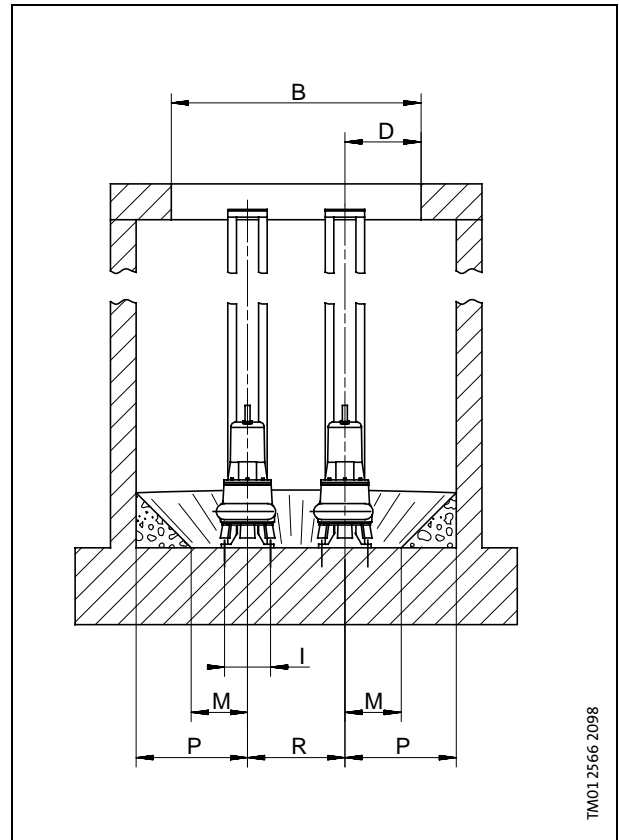
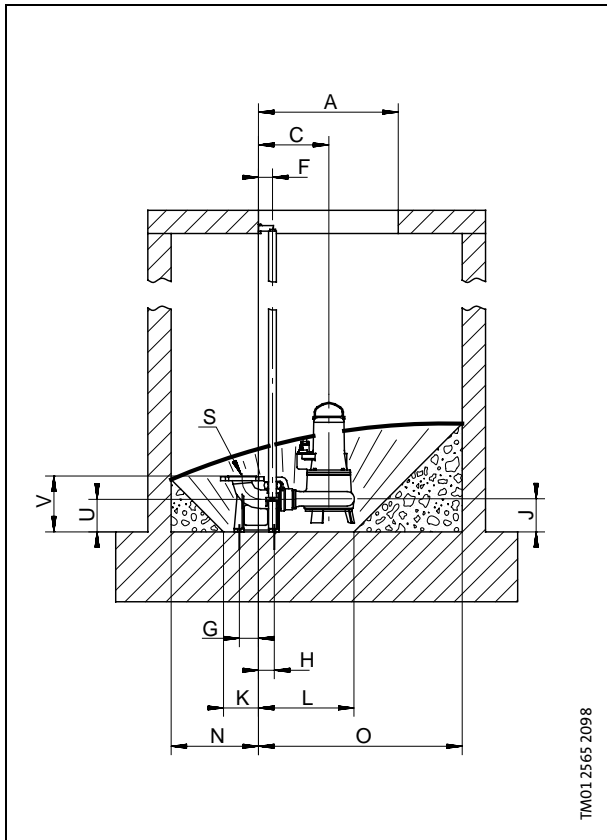

### One-pump installation on auto-coupling

Pump type	A	B	C	D	E	F	G	H	I	J	K	L	M	N	O	P	S	T	U	V
AP51.65.07	ø600	ø600	300	300	70	60	82	68	180	85	150	410	220	350	650	500	DN 65	1"	140	240
AP51.65.12	ø600	ø600	300	300	70	60	82	68	180	85	150	410	220	350	650	500	DN 65	1"	140	240
AP51.65.17	ø600	ø600	300	300	70	60	82	68	180	85	150	410	220	350	650	500	DN 65	1"	140	240
AP51.65.22	ø600	ø600	300	300	70	60	82	68	180	85	150	410	220	350	650	500	DN 65	1"	140	240
AP51.65.22.Ex	ø600	ø600	300	300	70	60	82	68	180	85	150	410	220	350	650	500	DN 65	1"	140	240

### Two-pump installation on auto-coupling

Pump type	A	B	C	D	E	F	G	H	I	J	K	L	M	N	O	P	R	S	T	U	V
AP51.65.07	600	975	300	297	70	60	82	68	180	85	150	410	220	375	875	435	380	DN 65	1"	140	240
AP51.65.12	600	975	300	297	70	60	82	68	180	85	150	410	220	375	875	435	380	DN 65	1"	140	240
AP51.65.17	600	975	300	297	70	60	82	68	180	85	150	410	220	375	875	435	380	DN 65	1"	140	240
AP51.65.22	600	975	300	297	70	60	82	68	180	85	150	410	220	375	875	435	380	DN 65	1"	140	240
AP51.65.22.Ex	600	975	300	297	70	60	82	68	180	85	150	410	220	375	875	435	380	DN 65	1"	140	240

## AP65 Vortex



The pumps are used for pumping sewage, wastewater, considerable quantities of surface water and ground water in places such as

- public buildings,
- blocks of flats,
- municipal pump pits,
- single-family houses,
- factories,
- garages,
- underground car parks,
- car wash areas and
- sludge-containing water.

## Pump and stator housing

The pump housing and the stator housing are made of cast iron.

The stator housing is dry, i.e. not oil-filled.

## Discharge

All AP65 V pumps have a horizontal discharge port.

AP65.65 V : R 2½ for threaded connection

AP65.100 V : DN 100, DIN flange

## Shaft and bearings

The shaft is made of stainless steel. It rotates in an upper and an lower maintenance-free prelubricated ball bearing.

## Impeller

The impeller is a vortex impeller in cast iron EN-GJL-250 with a free passage of 65 mm in the pump housing. Cast iron is chosen as it is resistant towards mechanically wearing particles.

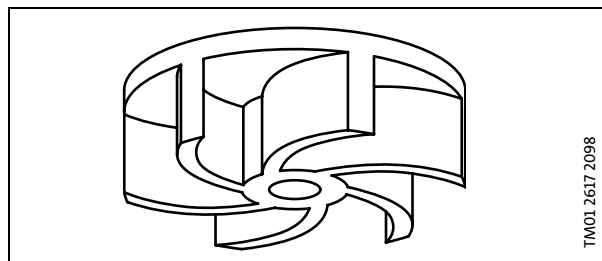

## Shaft seal

Combination of mechanical bellows seal and lip seal. The primary shaft seal has silicon carbide/silicon carbide seal faces. The secondary shaft seal is a lip seal. The chamber between the shaft seals is filled with 0.01 litre of oil.

## Motor cable

Standard pumps 10 m: H07RNF.

## Materials

Description	Materials	DIN W.-Nr.	AISI/ASTM
Stator housing	Cast iron EN-GJL-250	0.6025	ASTM 35B
Pump housing	Cast iron EN-GJL-250	0.6025	ASTM 35B
Wear plate	Cast iron EN-GJL-250	0.6025	ASTM 35B
Impeller	Cast iron EN-GJL-250	0.6025	ASTM 35B
Shaft	Stainless steel	1.4104	AISI 430F
Bearings	Heavy-duty prelubricated ball bearings		
Screws	Stainless steel	1.4301	AISI 304
Oil	Shell Ondina 15, non-toxic		

## Control box

Further information about control box, float switch, and level control, see page 44.

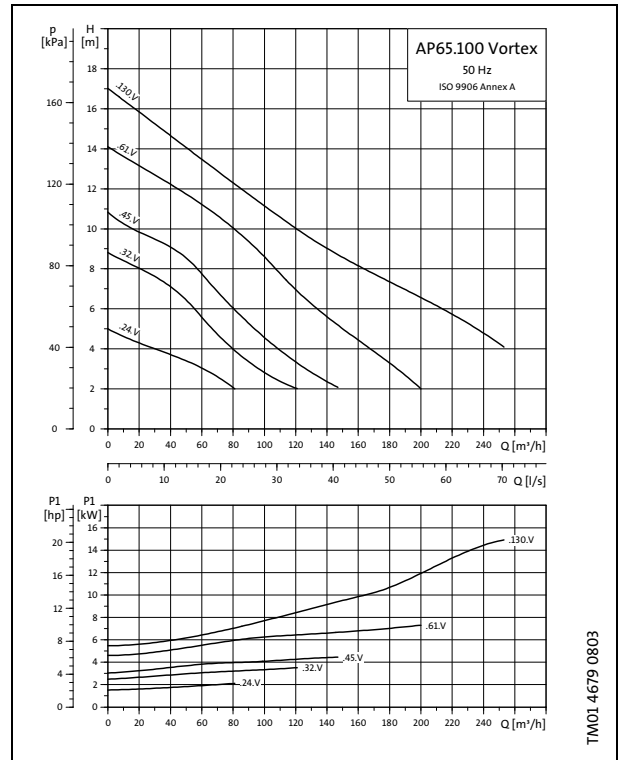
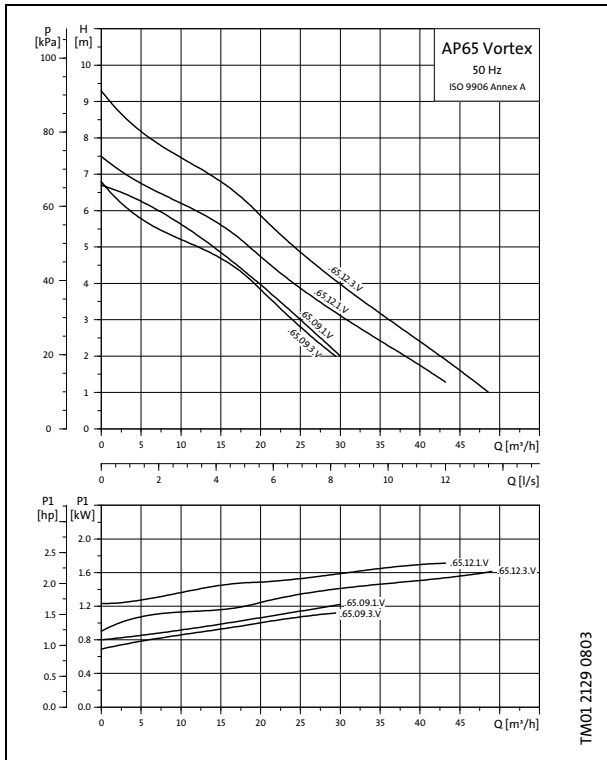

## AP65.65 Vortex

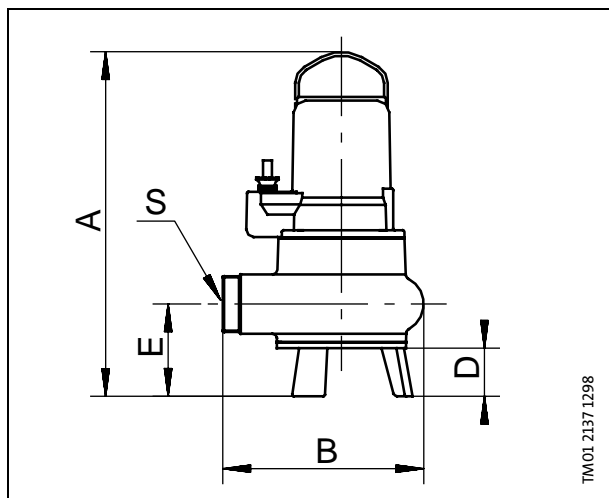

## AP65.100 Vortex

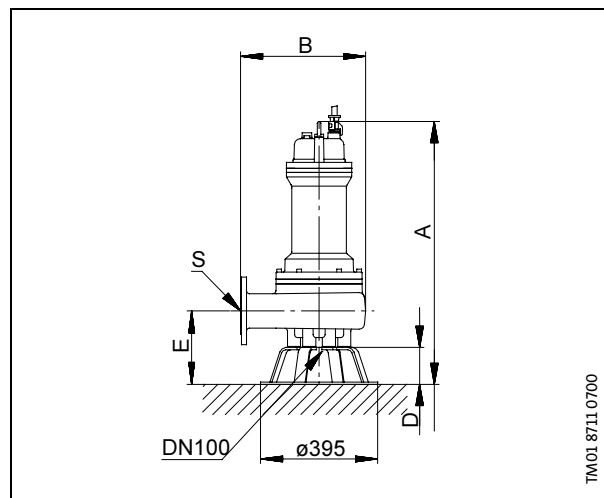

Pump type	Voltage	P <sub>1</sub> [kW]	P <sub>2</sub> [kW]	n [min <sup>-1</sup> ]	I <sub>n</sub> [A]	Cos φ	I <sub>start</sub> /I <sub>n</sub>	Dimensions [mm]					Weight [kg]
								A	B	D	E	S	
AP65.65.09.1.V	1 x 230 V	1.2	0.9	2900	5.1	0.25	2.8	465	271	65	124	R 2½	24
AP65.65.09.A.1.V	1 x 230 V	1.2	0.9	2900	5.1	0.25	2.8	465	271	65	124	R 2½	24
AP65.65.09.3.V	3 x 230 V	1.2	0.9	2900	3.9	0.83	4.5	465	271	65	124	R 2½	24
AP65.65.09.A.3.V	3 x 230 V	1.2	0.9	2900	3.9	0.83	4.5	465	271	65	124	R 2½	24
AP65.65.09.3.V	3 x 400 V	1.2	0.9	2900	1.9	0.91	5.1	465	271	65	124	R 2½	24
AP65.65.09.A.3.V	3 x 400 V	1.2	0.9	2900	1.9	0.91	5.1	465	271	65	124	R 2½	24
AP65.65.12.1.V	1 x 230 V	1.6	1.2	2900	7.8	0.30	2.9	465	271	65	124	R 2½	27
AP65.65.12.1.V.Ex	1 x 230 V	1.6	1.2	2900	7.8	0.30	2.9	465	271	65	124	R 2½	27
AP65.65.12.A.1.V	1 x 230 V	1.6	1.2	2900	7.8	0.30	2.9	465	271	65	124	R 2½	27
AP65.65.12.3.V	3 x 230 V	1.6	1.2	2900	5.5	0.72	4.9	465	271	65	124	R 2½	27
AP65.65.12.A.3.V	3 x 230 V	1.6	1.2	2900	5.5	0.72	4.9	465	271	65	124	R 2½	27
AP65.65.12.3.V	3 x 400 V	1.6	1.2	2900	2.9	0.72	4.6	465	271	65	124	R 2½	27
AP65.65.12.3.V.Ex	3 x 400 V	1.6	1.2	2900	2.9	0.72	4.6	465	271	65	124	R 2½	27
AP65.65.12.A.3.V	3 x 400 V	1.6	1.2	2900	2.9	0.72	4.6	465	271	65	124	R 2½	27
AP65.100.24.3.V	3 x 400 V	3.0	2.4	1450	3.7	0.88	9.7	851	422	125	248	DN 100	114
AP65.100.24.3.V.Ex	3 x 400 V	3.0	2.4	1450	3.7	0.88	9.7	851	422	125	248	DN 100	116
AP65.100.32.3.V	3 x 400 V	4.0	3.2	1450	7.5	0.84	6.0	883	459	125	255	DN 100	118
AP65.100.32.3.V.Ex	3 x 400 V	4.0	3.2	1450	7.5	0.84	6.0	883	459	125	255	DN 100	121
AP65.100.45.3.V	3 x 400 V	5.5	4.5	1450	10.5	0.83	6.1	953	459	125	255	DN 100	121
AP65.100.45.3.V.Ex	3 x 400 V	5.5	4.5	1450	10.5	0.83	6.1	953	459	125	255	DN 100	124
AP65.100.61.3.V	3 x 400 V	7.5	6.1	1450	13.6	0.81	5.7	953	459	125	255	DN 100	125
AP65.100.61.3.V.Ex	3 x 400 V	7.5	6.1	1450	13.6	0.81	5.7	953	459	125	255	DN 100	128
AP65.100.130.3.V	3 x 400 V	16.5	13.0	1450	30.0	0.81	3.5	1109	459	125	255	DN 100	192
AP65.100.130.3.V.Ex	3 x 400 V	16.5	13.0	1450	30.0	0.81	3.5	1109	459	125	255	DN 100	205

## AP65 Vortex installations

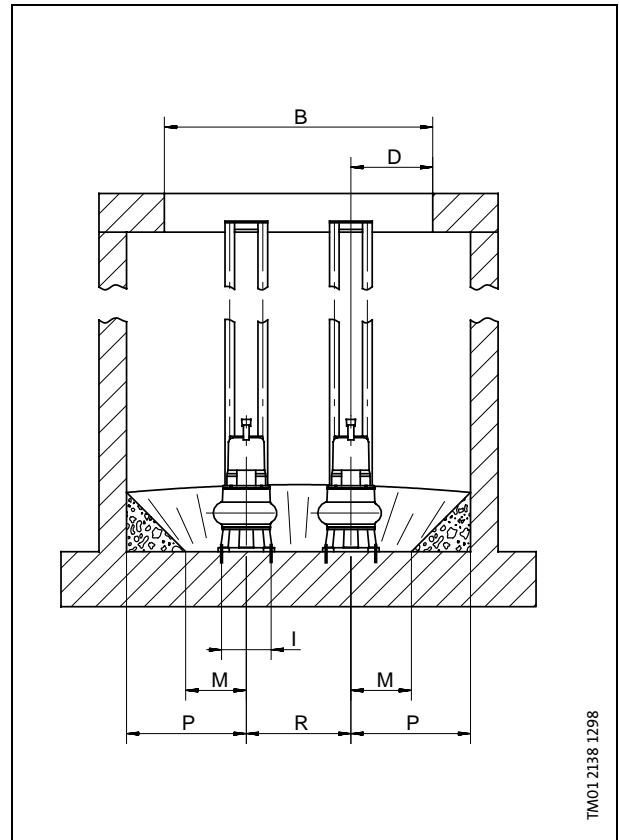
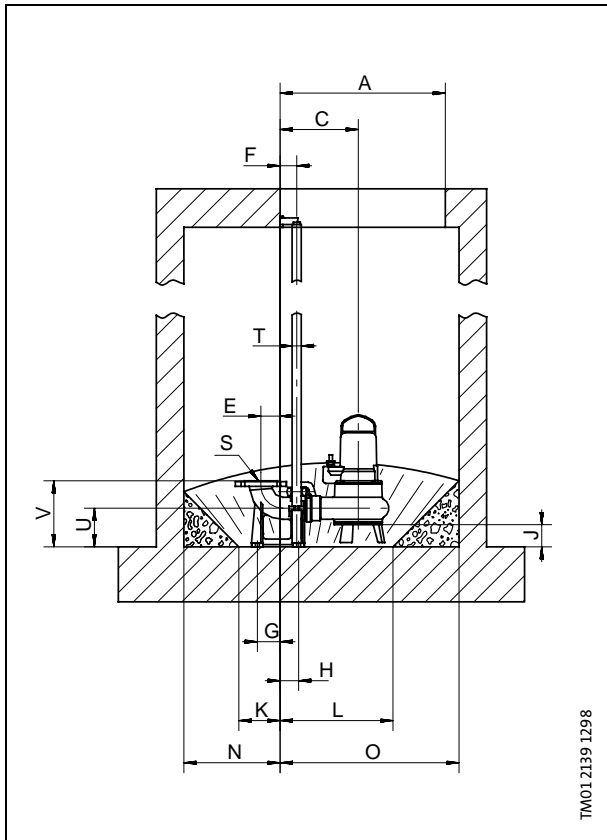

### One-pump installation on auto-coupling

Pump type	A	B	C	D	E	F	G	H	I	J	K	L	M	N	O	P	S	T	U	V
AP65.65.09.1.V	ø600	ø600	284	300	70	60	82	67	100/180	81	150	410	220	350	650	500	DN65	1"	140	240
AP65.65.09.3.V	ø600	ø600	284	300	70	60	82	67	100/180	81	150	410	220	350	650	500	DN65	1"	140	240
AP65.65.12.1.V	ø600	ø600	284	300	70	60	82	67	100/180	81	150	410	220	350	650	500	DN65	1"	140	240
AP65.65.12.3.V	ø600	ø600	284	300	70	60	82	67	100/180	81	150	410	220	350	650	500	DN65	1"	140	240

### Two-pump installation on auto-coupling

Pump type	A	B	C	D	E	F	G	H	I	J	K	L	M	N	O	P	R	S	T	U	V
AP65.65.09.1.V	600	975	284	297	70	60	82	67	100/180	81	150	410	220	375	875	435	380	DN 65	1"	140	240
AP65.65.09.3.V	600	975	284	297	70	60	82	67	100/180	81	150	410	220	375	875	435	380	DN 65	1"	140	240
AP65.65.12.1.V	600	975	284	297	70	60	82	67	100/180	81	150	410	220	375	875	435	380	DN 65	1"	140	240
AP65.65.12.3.V	600	975	284	297	70	60	82	67	100/180	81	150	410	220	375	875	435	380	DN 65	1"	140	240

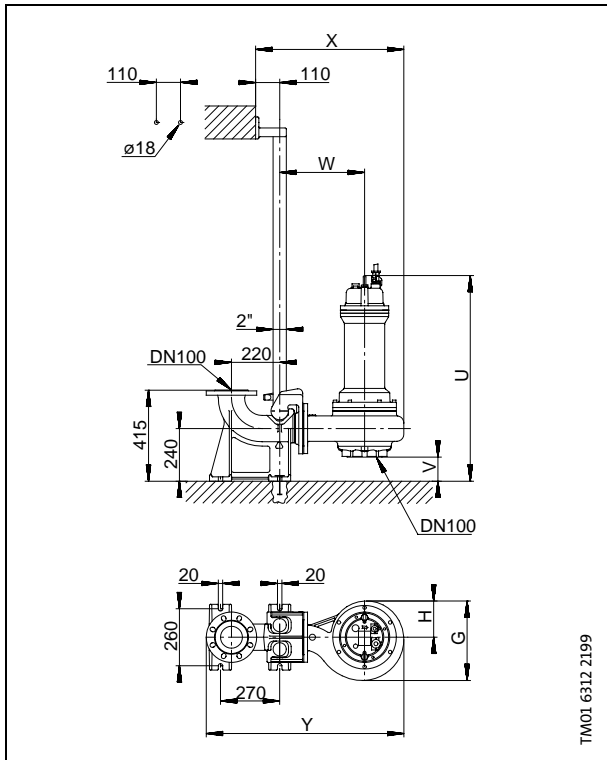

## DN 100 auto-coupling

Pump type	Dimensions [mm]						
	G	H	U	V	W	X	Y
AP65.100.24.V (Ex)	323	147	879	117	372	639	864
AP65.100.32.V (Ex)	363	165	868	110	387	676	901
AP65.100.45.V (Ex)	363	165	938	110	387	676	901
AP65.100.61.V (Ex)	363	165	938	110	387	676	901
AP65.100.130.V (Ex)	363	165	1094	125	389	676	901

## AP70



The pumps are used for pumping sewage, wastewater, considerable quantities of surface water and ground water in places such as

- public buildings,
- blocks of flats,
- municipal pump pits,
- single-family houses,
- factories,
- garages,
- underground car parks and
- car wash areas.

## Approvals

AP70 and AP70.Ex: PA-I no. 4111  
 AP70.80: PA-I no. 3988

## Pump and stator housing

The pump housing and the stator housing are made of cast iron.

The stator housing is dry, i.e. not oil-filled.

## Discharge

All AP70 pumps have a horizontal discharge port with a DN 80 DIN flange. The flange of AP70.80.09 and AP70.80.13 is a removable, threaded flange. The port without flange is threaded R 3.

## Shaft and bearings

The shaft is made of stainless steel and rotates in maintenance-free prelubricated ball bearings.

The lower bearing is a double-row ball bearing.

## Impeller

The impeller is a closed single-channel cast iron impeller with a clearance of 70 mm. Cast iron is chosen as it is resistant towards mechanically wearing particles.

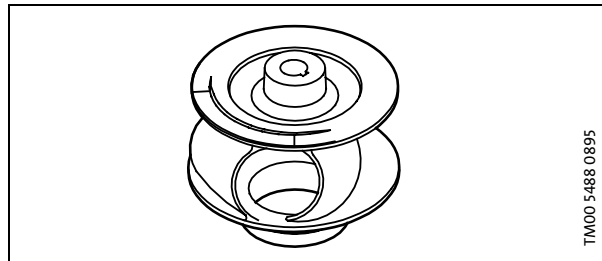

The inlet side of the pump housing is fitted with a replaceable neck ring.

## Shaft seals

Two mechanical bellows seals with silicon carbide/silicon carbide seal faces. The chamber between the shaft seals is filled with oil.

Pump type	Oil volume
AP70.80.09/13.(Ex)	0.8 litre
AP70.80.19/24.(Ex)	1.2 litres

## Motor cable

Standard pumps 10 m: H07RNF  
 Ex-pumps 10 m: H07RNF - PLUS

## Materials

Description	Materials	DIN W.-Nr.	AISI/ASTM
Stator housing	Cast iron EN-GJL-250	0.6025	ASTM 35B
Pump housing	Cast iron EN-GJL-250	0.6025	ASTM 35B
Neck ring	Bronze		
Impeller	Cast iron EN-GJL-250	0.6025	ASTM 35B
Shaft	Stainless steel	1.4104	AISI 430F
Bearings	Heavy-duty prelubricated ball bearings		
Screws	Stainless steel	1.4301	AISI 304
Oil	Shell Ondina 15, non-toxic		

## Level controller

Further information about level controller and float switch, see page 44 and page 72.



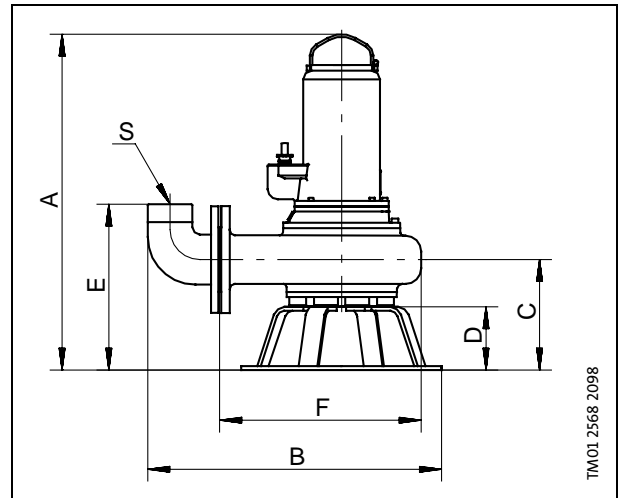
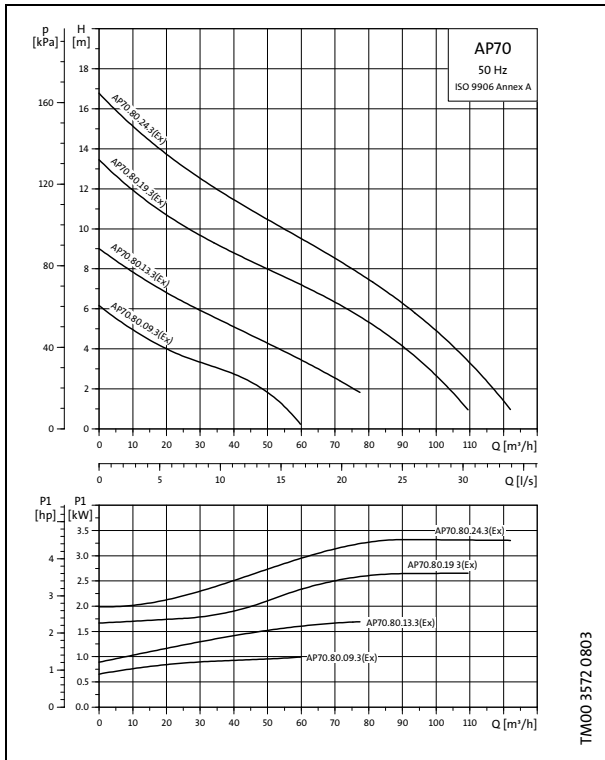

Elbow and base are accessories.

Pump type	Voltage	P <sub>1</sub> [kW]	P <sub>2</sub> [kW]	n [min <sup>-1</sup> ]	I <sub>n</sub> [A]	Cos φ	I <sub>start</sub> I <sub>n</sub>	Dimensions [mm]							Weight [kg]
								A	B	C	D	E	F	S	
AP70.80.09.3	3 x 230 V	1.2	0.9	1450	4.5	0.70	4.8	586	418	180	90	278	305	R 3	40
AP70.80.09.3	3 x 400 V	1.2	0.9	1450	2.6	0.70	4.6	586	418	180	90	278	305	R 3	40
AP70.80.09.3.Ex	3 x 230 V	1.2	0.9	1450	4.5	0.70	5.4	586	418	180	90	278	305	R 3	52
AP70.80.09.3.Ex	3 x 400 V	1.2	0.9	1450	2.6	0.70	4.0	586	418	180	90	278	305	R 3	52
AP70.80.13.3	3 x 230 V	1.7	1.3	1450	5.8	0.78	3.7	586	418	180	90	278	305	R 3	40
AP70.80.13.3	3 x 400 V	1.7	1.3	1450	3.3	0.78	3.6	586	418	180	90	278	305	R 3	40
AP70.80.13.3.Ex	3 x 230 V	1.7	1.3	1450	5.8	0.78	3.7	586	418	180	90	278	305	R 3	52
AP70.80.13.3.Ex	3 x 400 V	1.7	1.3	1450	3.3	0.78	3.6	586	418	180	90	278	305	R 3	52
AP70.80.19.3	3 x 230 V	2.7	1.9	1450	9.6	0.80	4.4	663	580	218	125	327	397	R 3	66
AP70.80.19.3	3 x 400 V	2.7	1.9	1450	5.5	0.80	4.2	663	580	218	125	327	397	R 3	66
AP70.80.19.3.Ex	3 x 230 V	2.7	1.9	1450	9.6	0.80	4.4	663	580	218	125	327	397	R 3	66
AP70.80.19.3.Ex	3 x 400 V	2.7	1.9	1450	5.5	0.80	4.2	663	580	218	125	327	397	R 3	66
AP70.80.24.3	3 x 230 V	3.5	2.4	1450	11.0	0.80	4.4	663	580	218	125	327	397	R 3	66
AP70.80.24.3	3 x 400 V	3.5	2.4	1450	6.3	0.80	4.3	663	580	218	125	327	397	R 3	66
AP70.80.24.3.Ex	3 x 230 V	3.5	2.4	1450	11.0	0.80	4.4	663	580	218	125	327	397	R 3	66
AP70.80.24.3.Ex	3 x 400 V	3.5	2.4	1450	6.3	0.80	4.3	663	580	218	125	327	397	R 3	66

## AP70 installations

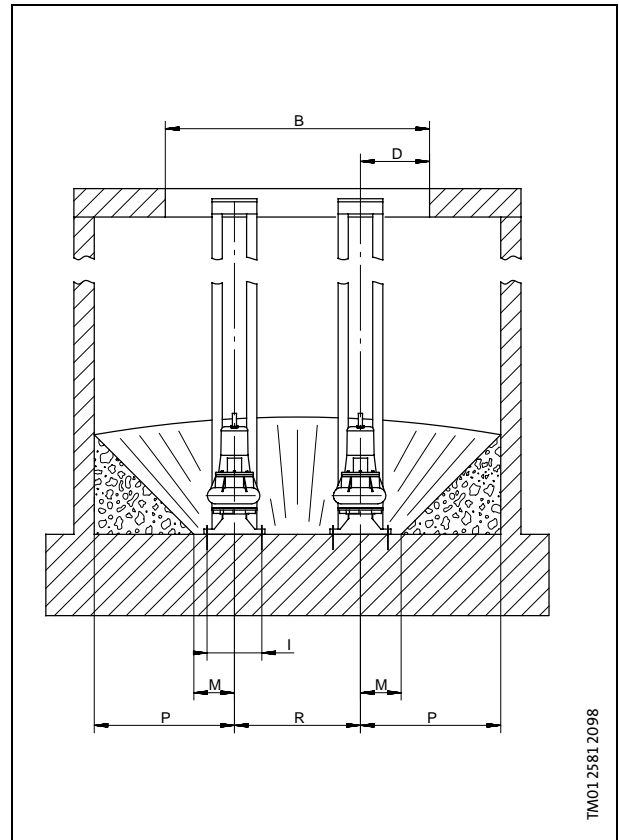
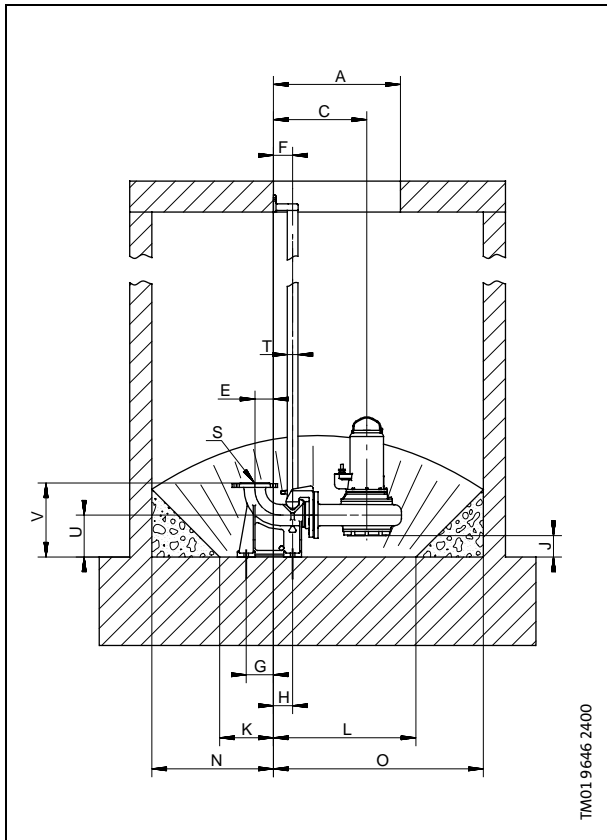

### One-pump installation on auto-coupling

Pump type	A	B	C	D	E	F	G	H	I	J	K	L	M	N	O	P	S	T	U	V
AP70.80.09.(Ex)	600	600	340	340	83	87	123	87	270	100	243	645	200	550	950	690	DN 80	1½"	190	335
AP70.80.13.(Ex)	600	600	340	340	83	87	123	87	270	100	243	645	200	550	950	690	DN 80	1½"	190	335
AP70.80.19.(Ex)	600	600	340	340	83	87	123	87	270	100	243	645	200	550	950	690	DN 80	1½"	190	335
AP70.80.24.(Ex)	600	600	340	340	83	87	123	87	270	100	243	645	200	550	950	690	DN 80	1½"	190	335

### Two-pump installation on auto-coupling

Pump type	A	B	C	D	E	F	G	H	I	J	K	L	M	N	O	P	R	S	T	U	V
AP70.80.09.(Ex)	600	1300	340	340	83	87	123	87	270	100	243	645	200	550	950	960	620	DN 80	1½"	190	335
AP70.80.13.(Ex)	600	1300	340	340	83	87	123	87	270	100	243	645	200	550	950	960	620	DN 80	1½"	190	335
AP70.80.19.(Ex)	600	1300	340	340	83	87	123	87	270	100	243	645	200	550	950	960	620	DN 80	1½"	190	335
AP70.80.24.(Ex)	600	1300	340	340	83	87	123	87	270	100	243	645	200	550	950	960	620	DN 80	1½"	190	335

## DN 80 auto-coupling

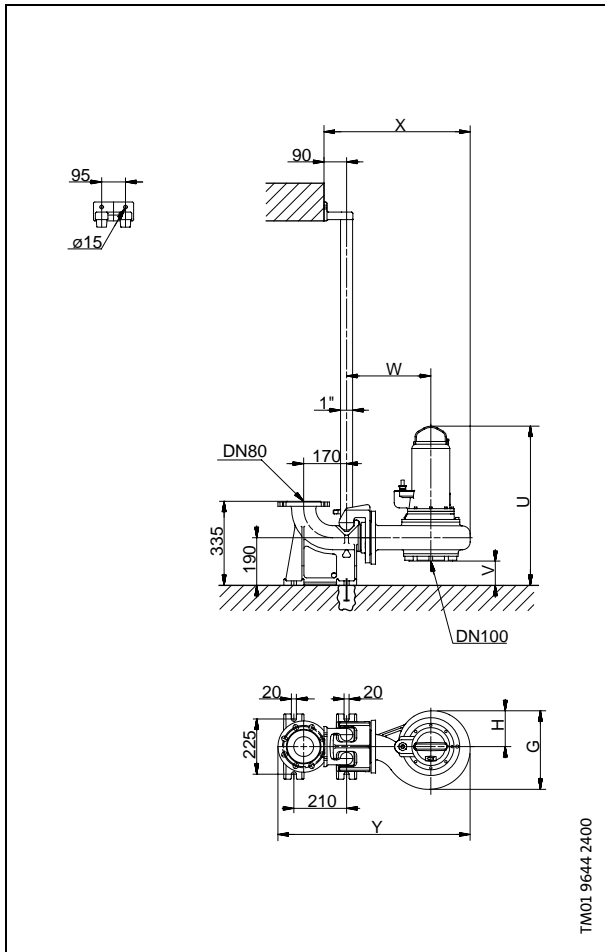

### Dimensions

Pump type	Dimensions [mm]						
	G	H	U	V	W	X	Y
AP70.80.09.(Ex)	258	125	596	100	253	465	648
AP70.80.13.(Ex)	258	125	596	100	253	465	648
AP70.80.19.(Ex)	313	143	635	97	326	570	753
AP70.80.24.(Ex)	313	143	635	97	326	570	753

## DN 100 auto-coupling

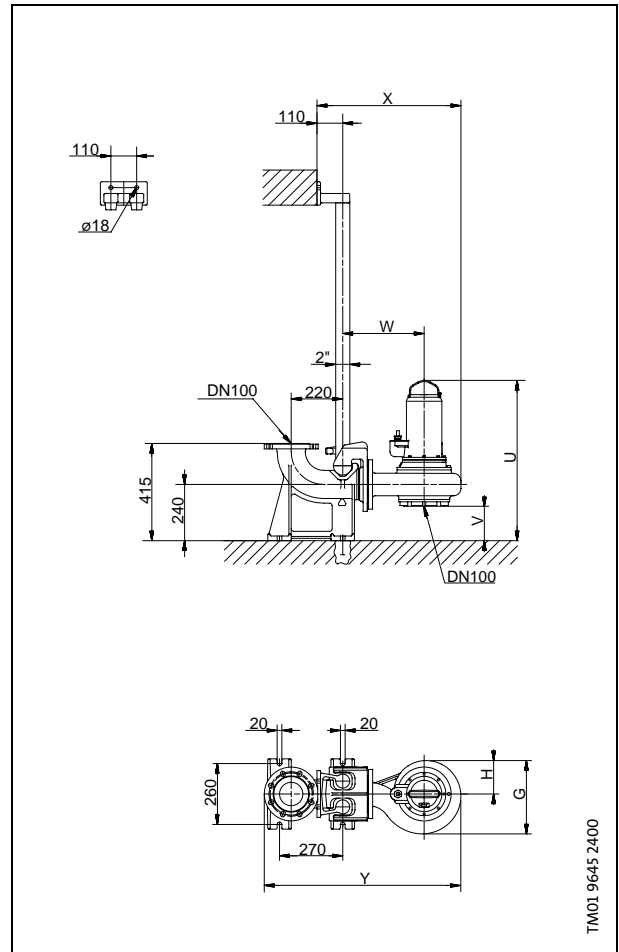

### Dimensions

Pump type	Dimensions [mm]						
	G	H	U	V	W	X	Y
AP70.80.09.(Ex)	258	125	616	150	291	503	731
AP70.80.13.(Ex)	258	125	616	150	291	503	731
AP70.80.19.(Ex)	313	143	685	147	364	608	836
AP70.80.24.(Ex)	313	143	685	147	364	608	836

## Control box

### Variants

The AP pump range comprises versions with or without control box and float switch, versions designed for single-phase or three-phase power supply versions.

All types are designed for voltage tolerances of  $\pm 10\%$ .

### Pumps with control box and float switch

Some AP pumps can be supplied with a float switch for automatic start/stop of the pump. The float switch cable should be fastened to the retainer on the pump handle.

The difference in level between start and stop may be adjusted by adjusting the free length of cable between the float switch and the retainer.

**Large difference in level:** Long cable.

**Small difference in level:** Short cable.

The float switch is connected directly to the control box through a 10 metres long cable.

The mains cable between the pump and the control box is 10 metres long. The mains cable of the control box is an 0.8 metres long free cable end.

The control box includes a motor starter, and for single-phase pumps also an operating capacitor. The pumps require no further motor protection.

An alarm signal can be given in case of a too high level by means of a separate float switch connected to an alarm. The high-level alarm switch and the alarm are available as accessories.

Further information about control boxes for a specific pump type, see "Product range", page 81.

### Pumps with control box without float switch for manual on/off operation

The mains cable between the pump and the control-box is 10 metres long. The mains cable of the control box is an 0.8 metres long free cable end.

The control box includes a motor starter and an operating capacitor but no relays for float switch.

### Pumps without control box

Pumps without control box must be connected to a separate motor starter. The motor starter is available as an accessory.

Single-phase pumps must also be connected to a capacitor.

### Level controller

A level controller and switches are available as optional extras for the control, monitoring and protection of three-phase 50 Hz AP pumps. Level controller LC is designed for one-pump operation, and LCD for two-pump operation.

The level controller incorporates motor starter, contactors and light-emitting diodes (LC/LCD) for indication of operating condition.

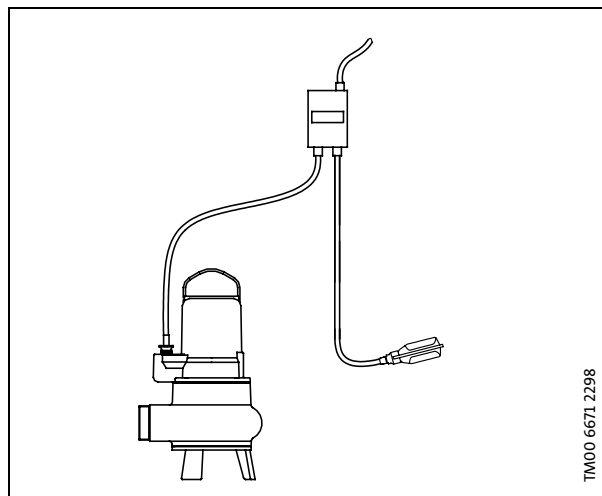

Pump with control box and float switch.

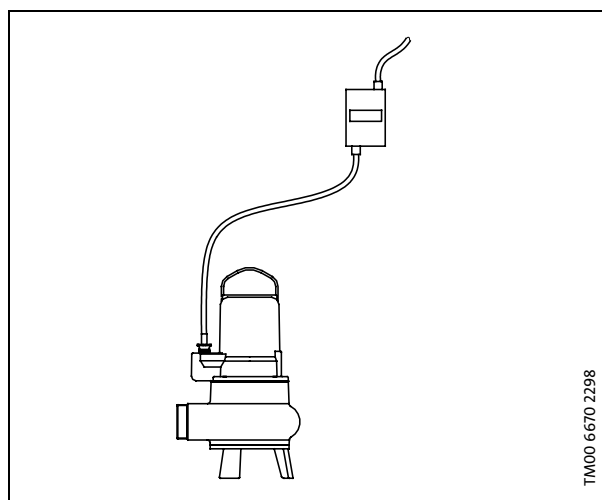

Pumps with control box without float switch for manual on/off operation.

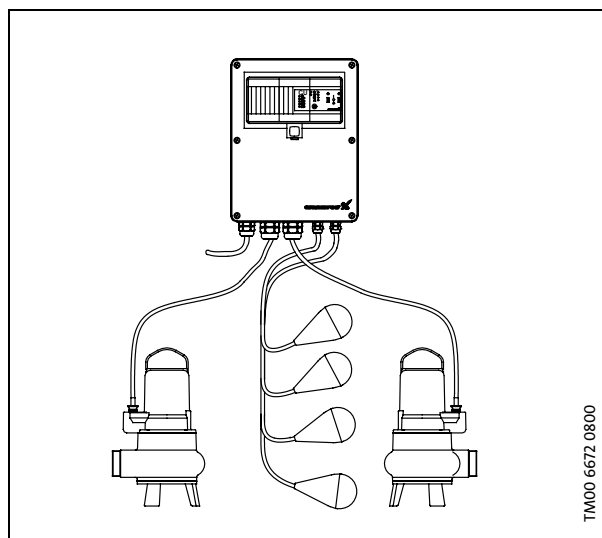

Two pumps with level controller LCD.

## AP80 Vortex



TM01 6084.1599

The pumps are used for pumping sewage, wastewater, considerable quantities of surface water and ground water in places such as

- municipal pump pits,
- public buildings,
- blocks of flats,
- factories,
- garages,
- underground car parks,
- car wash areas,
- restaurants and
- hotels.

## Pump and stator housing

The pump housing and the stator housing are made of cast iron.

## Discharge

All AP80 Vortex pumps have a horizontal discharge port for flange connection (DN 80 and DN 100).

## Shaft and bearings

The shaft is made of stainless steel. It rotates in an upper and an lower maintenance-free prelubricated ball bearings.

## Impeller

The impeller is a vortex impeller in cast iron EN-GJL-250 with a free passage of 80 mm in the pump housing. Cast iron is chosen as it is resistant towards mechanically wearing particles.

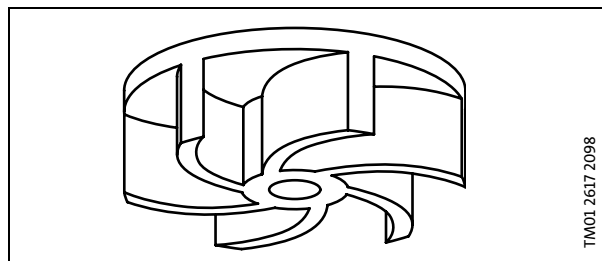

TM01 2617 2098

## Shaft seal

Two mechanical bellows seals with have siliconcarbide/siliconcarbide seal faces.

The chamber between the shaft seals is filled with oil.

Pump type	Oil volume
AP80.80.10 - 13	0.8 litres
AP80.80.20 - 26	1.2 litres
AP80.80(100).48 - 65	1.7 litres
AP80.80(100).92 - 107	3 litres

## Motor cable

Standard pumps 10 m: H07RNF.

Ex-pumps 10 m: H07RNF - PLUS.

## Materials

Description	Materials	DIN W.-Nr.	AISI/ASTM
Stator housing	Cast iron EN-GJL-250	0.6025	ASTM 35B
Pump housing	Cast iron EN-GJL-250	0.6025	ASTM 35B
Wear plate	Cast iron EN-GJL-250	0.6025	ASTM 35B
Impeller	Cast iron EN-GJL-250	0.6025	ASTM 35B
Shaft	Stainless steel	1.4104	AISI 430F
Bearings	Heavy-duty prelubricated ball bearings		
Screws	Stainless steel	1.4301	AISI 304
Oil	Shell Ondina 15, non-toxic		

## Level controller

Further information about level controller and float switch, see page 44 and page 72.

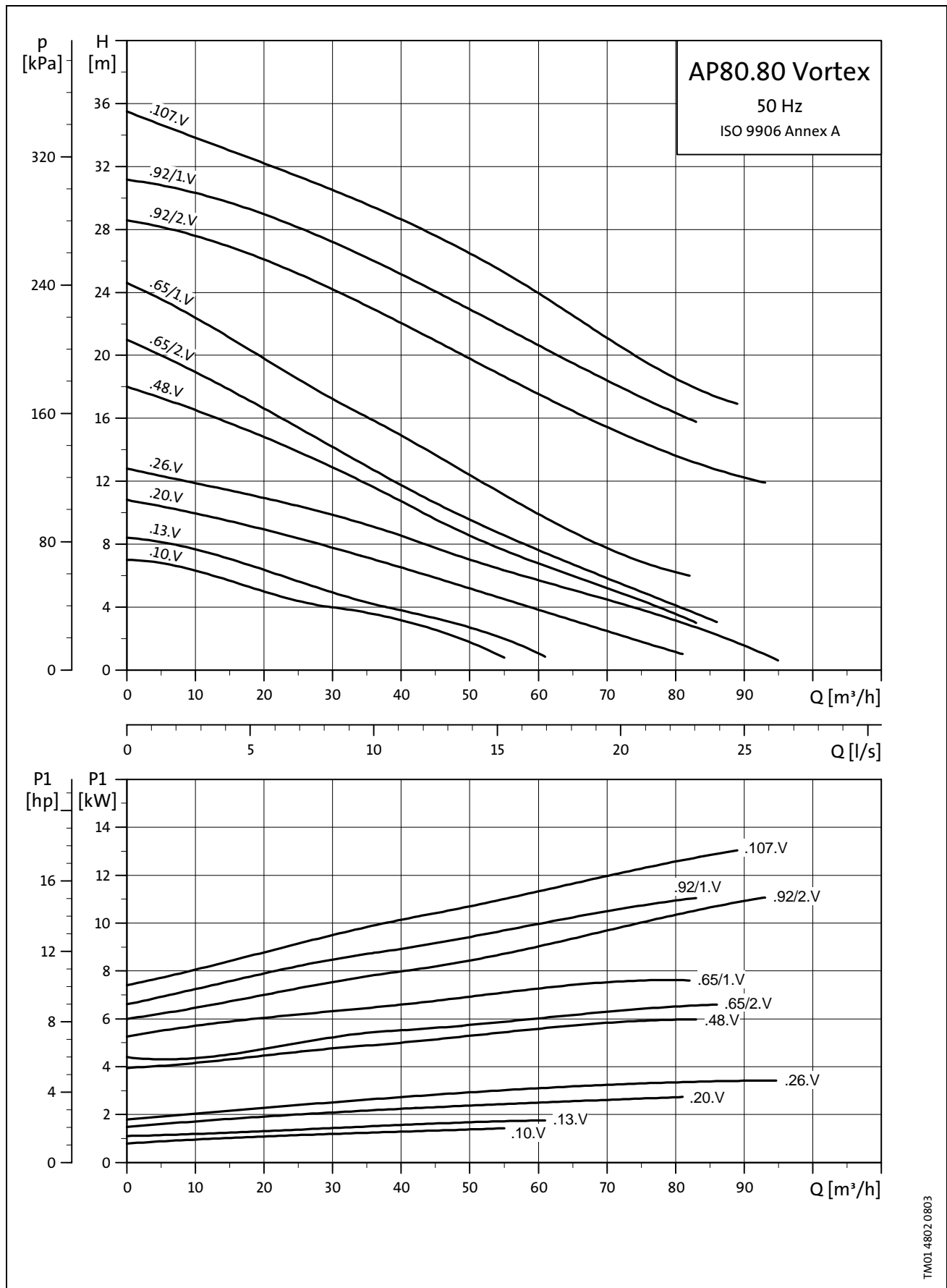

TM01.4802.0803

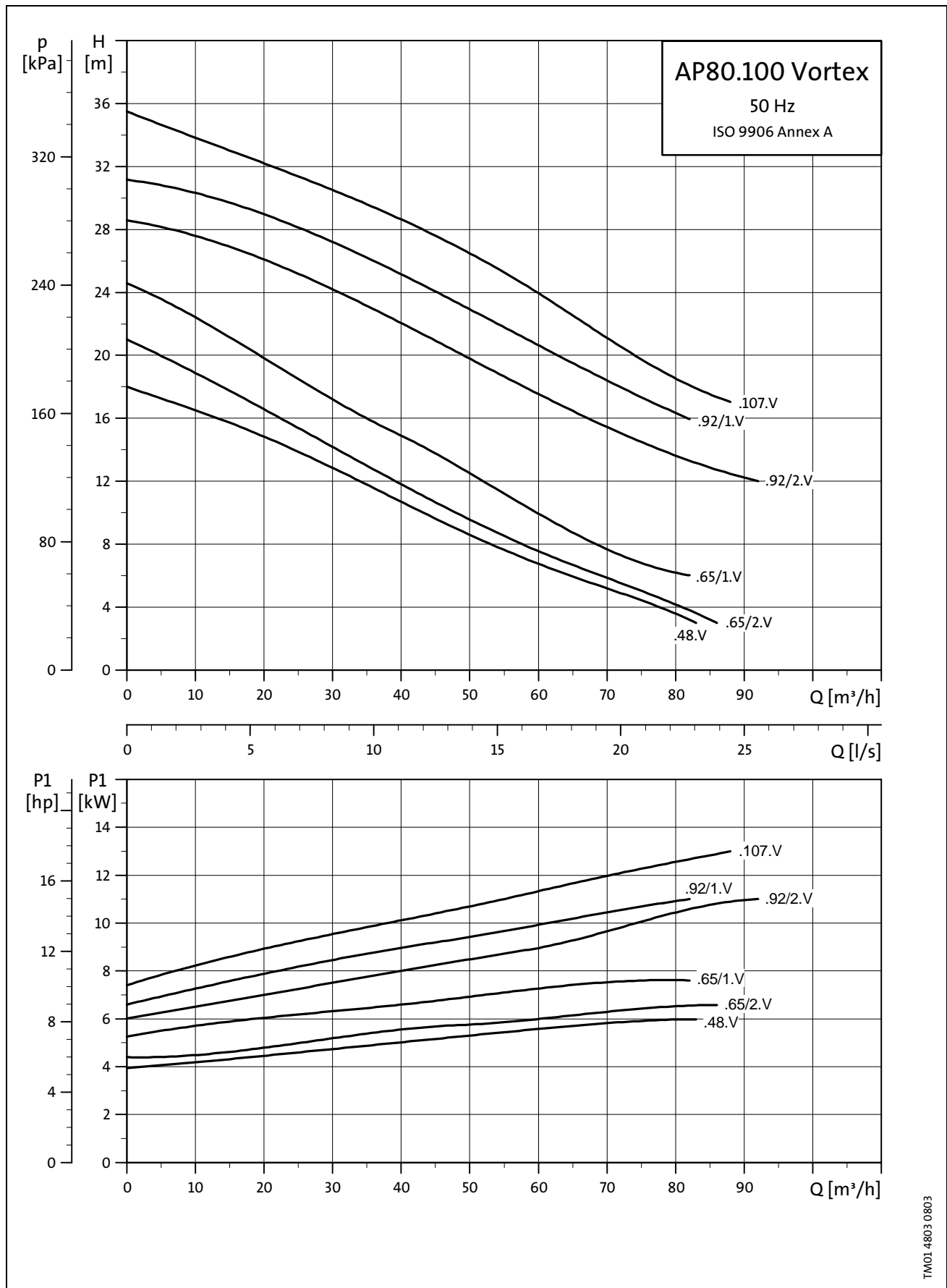

TM01.4803.0803

## One-pump installation on auto-coupling

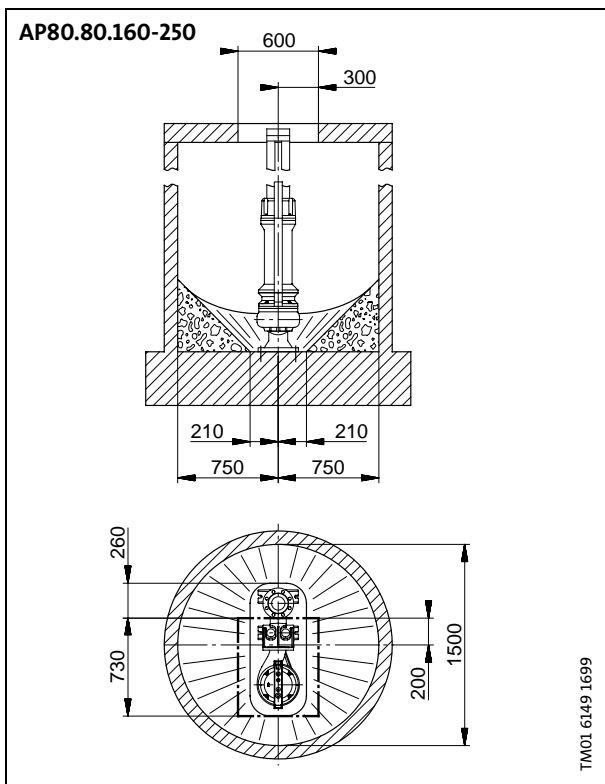
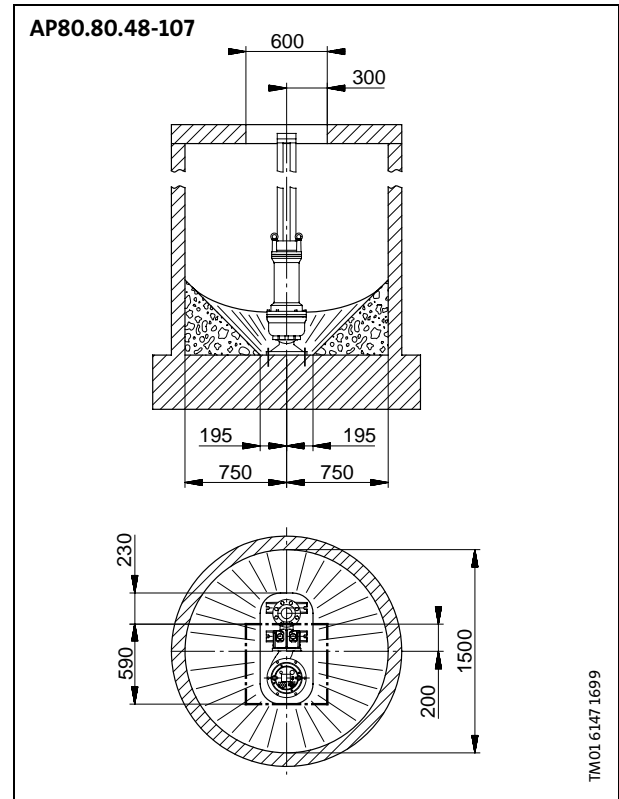
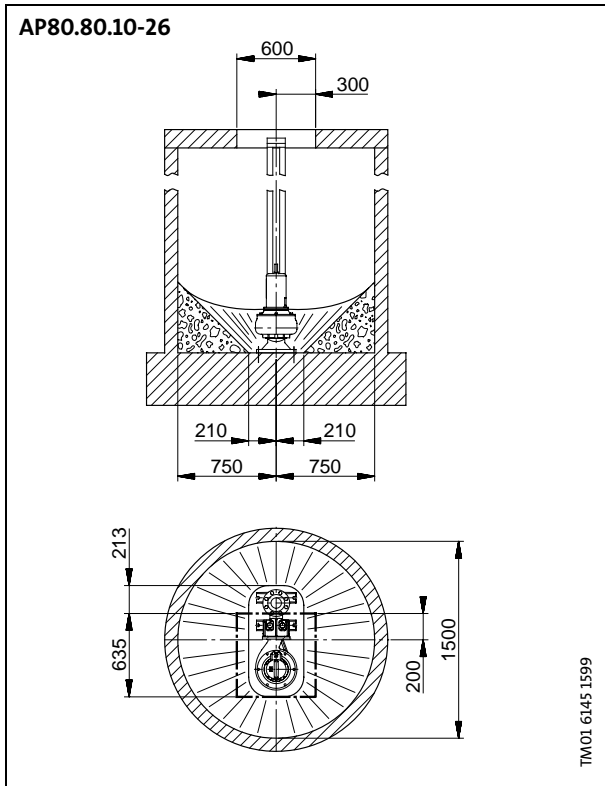



## Two-pump installation on auto-coupling

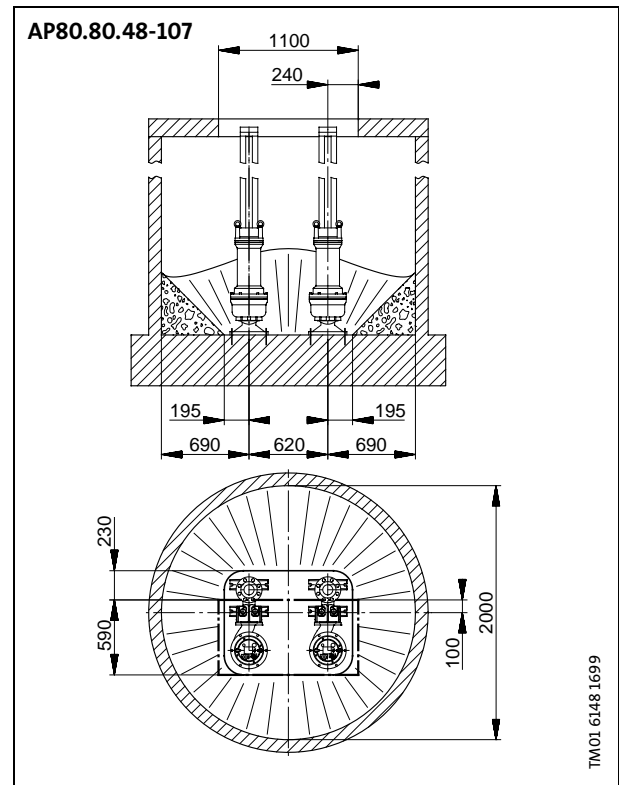
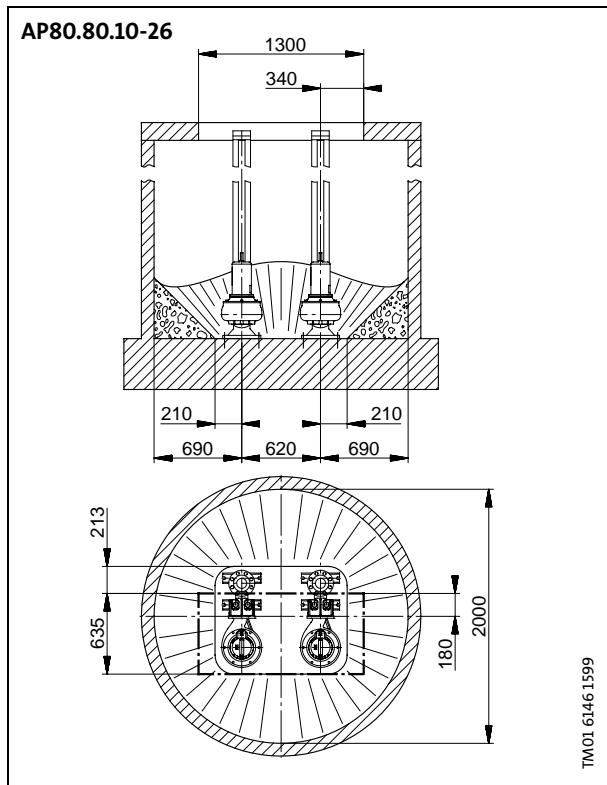

## DN 80 auto-coupling

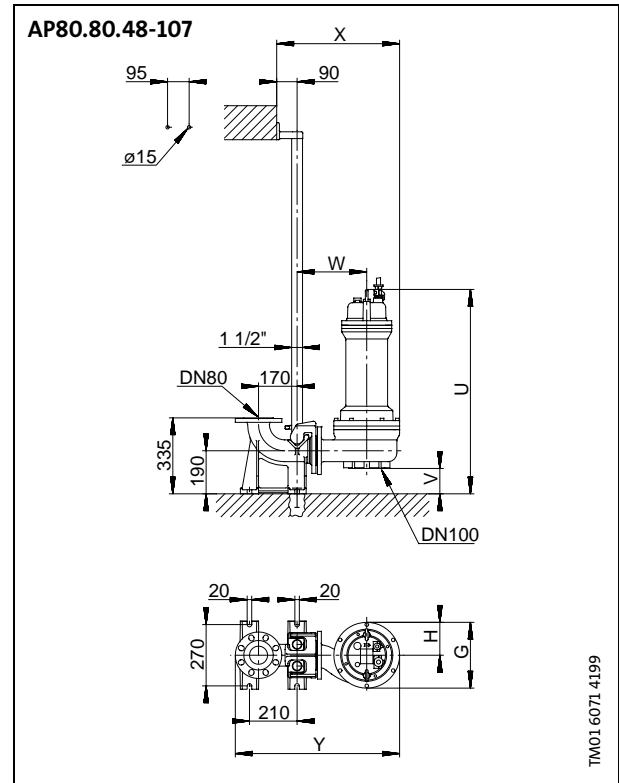
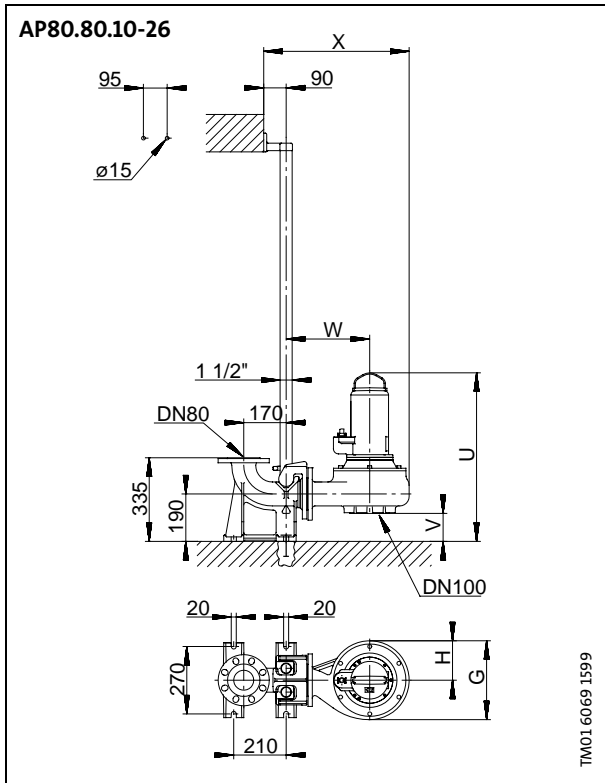

## DN 100 auto-coupling

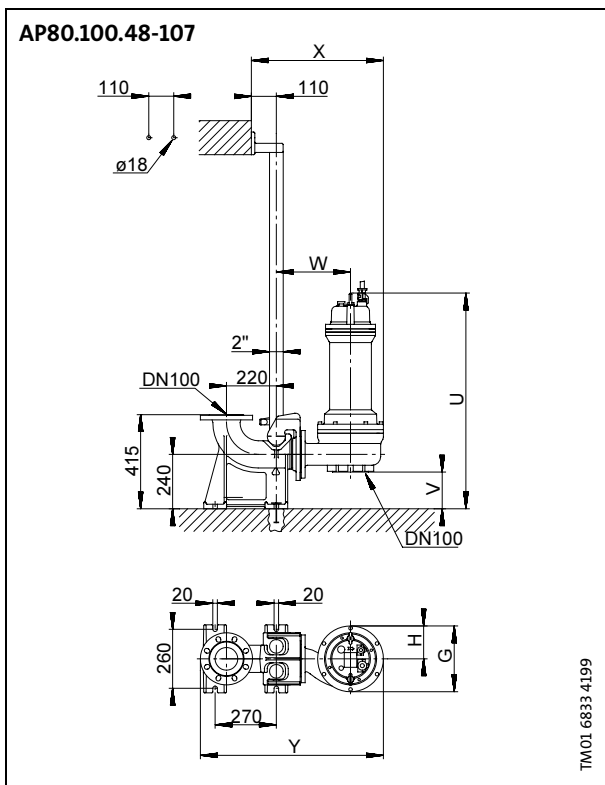

## Dimensions for installation on auto-coupling DN 80

Pump type	Dimensions [mm]						
	G	H	U	V	W	X	Y
AP80.80.10.V	290	145	628	112	305	540	723
AP80.80.10.V.Ex	290	145	628	112	305	540	723
AP80.80.13.V	290	145	628	112	305	540	723
AP80.80.13.V.Ex	290	145	628	112	305	540	723
AP80.80.20.V	316	158	675	112	335	583	766
AP80.80.20.V.Ex	316	158	675	112	335	583	766
AP80.80.26.V	316	158	675	112	335	583	766
AP80.80.26.V.Ex	316	158	675	112	335	583	766
AP80.80.48.V	290	145	831	112	307	542	725
AP80.80.48.V.Ex	290	145	831	112	307	542	725
AP80.80.65/2.V	290	145	831	112	307	542	725
AP80.80.65/2.V.Ex	290	145	831	112	307	542	725
AP80.80.65/1.V	290	145	831	112	307	542	725
AP80.80.65/1.V.Ex	290	145	831	112	307	542	725
AP80.80.92/2.V	290	145	901	112	307	542	725
AP80.80.92/2.V.Ex	290	145	901	112	307	542	725
AP80.80.92/1.V	290	145	901	112	307	542	725
AP80.80.92/1.V.Ex	290	145	901	112	307	542	725
AP80.80.107.V	290	145	901	112	307	542	725
AP80.80.107.V.Ex	290	145	901	112	307	542	725

## Dimensions for installation on auto-coupling DN 100

Pump type	Dimensions [mm]						
	G	H	U	V	W	X	Y
AP80.100.48.V	290	145	871	152	347	602	827
AP80.100.48.V.Ex	290	145	871	152	347	602	827
AP80.100.65/2.V	290	145	871	152	347	602	827
AP80.100.65/2.V.Ex	290	145	871	152	347	602	827
AP80.100.65/1.V	290	145	871	152	347	602	827
AP80.100.65/1.V.Ex	290	145	871	152	347	602	827
AP80.100.92/2.V	290	145	941	152	347	602	827
AP80.100.92/2.V.Ex	290	145	941	152	347	602	827
AP80.100.92/1.V	290	145	941	152	347	602	827
AP80.100.92/1.V.Ex	290	145	941	152	347	602	827
AP80.100.107.V	290	145	941	152	347	602	827
AP80.100.107.V.Ex	290	145	941	152	347	602	827

## Vertical dry installation (D)

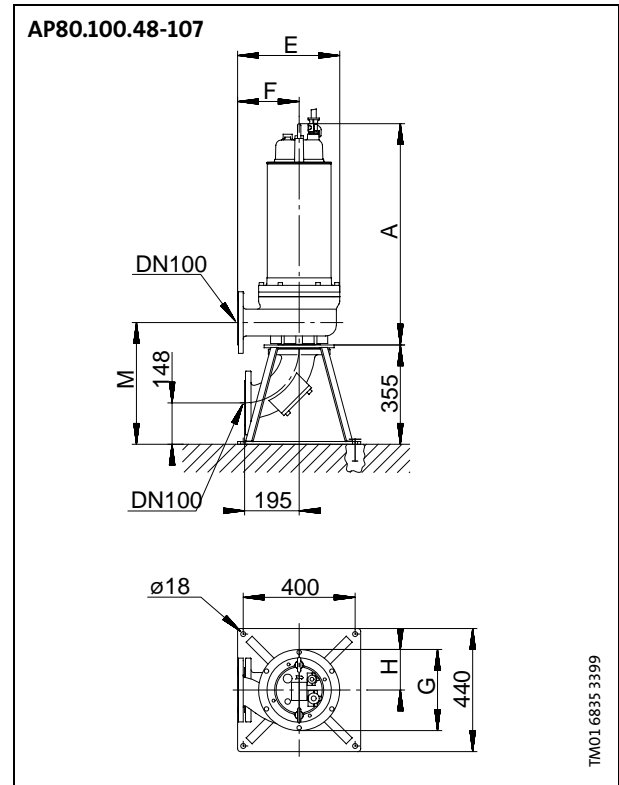
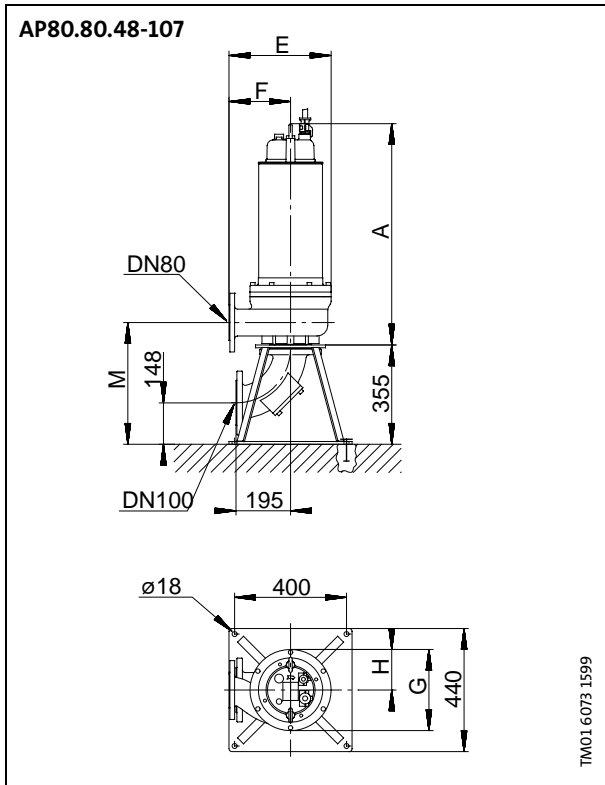

## Dimensions for vertical dry installation (D)

Pump type	Dimensions [mm]					
	A	E	F	G	H	M
AP80.80.48.V.D(H)	719	365	220	290	145	435
AP80.80.48.V.D(H).Ex	719	365	220	290	145	435
AP80.80.65/2.V.D(H)	719	365	220	290	145	435
AP80.80.65/2.V.D(H).Ex	719	365	220	290	145	435
AP80.80.65/1.V.D(H)	719	365	220	290	145	435
AP80.80.65/1.V.D(H).Ex	719	365	220	290	145	435
AP80.80.92/2.V.D(H)	789	365	220	290	145	435
AP80.80.92/1.V.D(H)	789	365	220	290	145	435
AP80.80.92/1.V.D(H).Ex	789	365	220	290	145	435
AP80.80.107.V.D(H)	789	365	220	290	145	435
AP80.80.107.V.D(H).Ex	789	365	220	290	145	435
AP80.100.48.V.D(H)	719	385	240	290	145	445
AP80.100.48.V.D(H).Ex	719	385	240	290	145	445
AP80.100.65/2.V.D(H)	719	385	240	290	145	445
AP80.100.65/2.V.D(H).Ex	719	385	240	290	145	445
AP80.100.65/1.V.D(H)	719	385	240	290	145	445
AP80.100.65/1.V.D(H).Ex	719	385	240	290	145	445
AP80.100.92/2.V.D(H)	789	385	240	290	145	445
AP80.100.92/1.V.D(H)	789	385	240	290	145	445
AP80.100.92/1.V.D(H).Ex	789	385	240	290	145	445
AP80.100.107.V.D(H)	789	385	240	290	145	445
AP80.100.107.V.D(H).Ex	789	385	240	290	145	445

## Horizontal dry installation (DH)

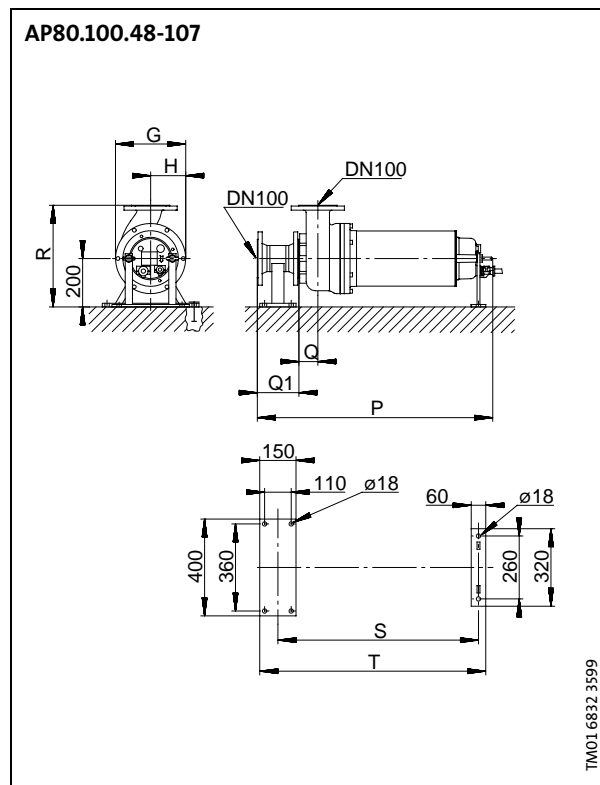
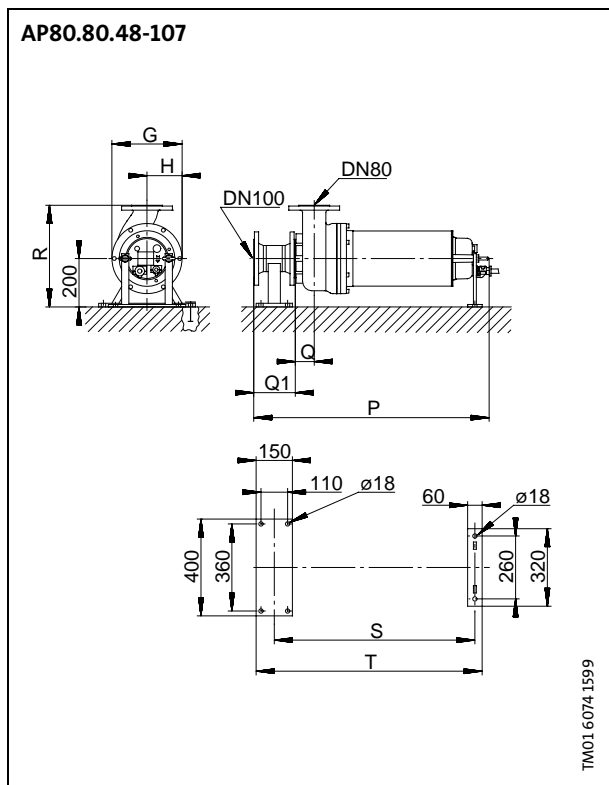

## Dimensions for horizontal dry installation (DH)

Pump type	Dimensions [mm]							
	G	H	P	Q	Q1	R	S	T
AP80.80.48.V.D(H)	290	145	903	78	172	420	759	864
AP80.80.48.V.D(H).Ex	290	145	903	78	172	420	759	864
AP80.80.65/2.V.D(H)	290	145	903	78	172	420	759	864
AP80.80.65/2.V.D(H).Ex	290	145	903	78	172	420	759	864
AP80.80.65/1.V.D(H)	290	145	903	78	172	420	759	864
AP80.80.65/1.V.D(H).Ex	290	145	903	78	172	420	759	864
AP80.80.92/2.V.D(H)	290	145	973	78	172	420	829	934
AP80.80.92/1.V.D(H)	290	145	973	78	172	420	829	934
AP80.80.92/1.V.D(H).Ex	290	145	973	78	172	420	829	934
AP80.80.107.V.D(H)	290	145	973	78	172	420	829	934
AP80.80.107.V.D(H).Ex	290	145	973	78	172	420	829	934
AP80.100.48.V.D(H)	290	145	903	88	172	440	759	864
AP80.100.48.V.D(H).Ex	290	145	903	88	172	440	759	864
AP80.100.65/2.V.D(H)	290	145	903	88	172	440	759	864
AP80.100.65/2.V.D(H).Ex	290	145	903	88	172	440	759	864
AP80.100.65/1.V.D(H)	290	145	903	88	172	440	759	864
AP80.100.65/1.V.D(H).Ex	290	145	903	88	172	440	759	864
AP80.100.92/2.V.D(H)	290	145	973	88	172	440	829	934
AP80.100.92/1.V.D(H)	290	145	973	88	172	440	829	934
AP80.100.92/1.V.D(H).Ex	290	145	973	88	172	440	829	934
AP80.100.107.V.D(H)	290	145	973	88	172	440	829	934
AP80.100.107.V.D(H).Ex	290	145	973	88	172	440	829	934

## Submerged free-standing installation

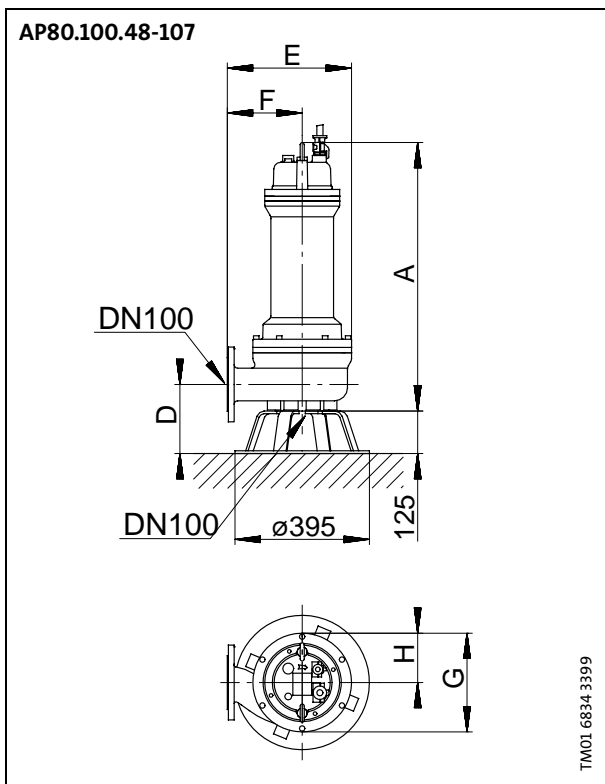
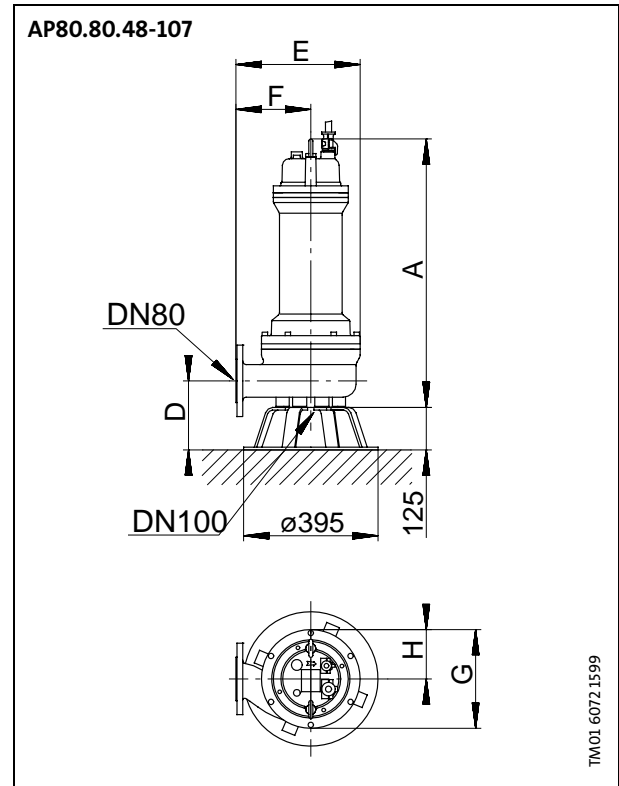
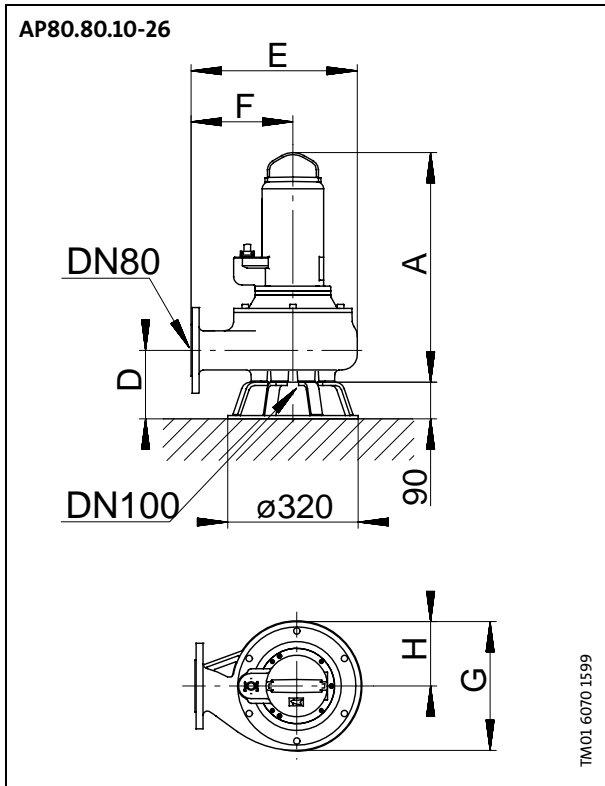

## Dimensions for submerged free-standing installation

Pump type	Dimensions [mm]					
	A	D	E	F	G	H
AP80.80.10.V	516	168	380	220	290	145
AP80.80.10.V.Ex	516	168	380	220	290	145
AP80.80.13.V	516	168	380	220	290	145
AP80.80.13.V.Ex	516	168	380	220	290	145
AP80.80.20.V	563	168	410	250	316	158
AP80.80.20.V.Ex	563	168	410	250	316	158
AP80.80.26.V	563	168	410	250	316	158
AP80.80.26.V.Ex	563	168	410	250	316	158
AP80.80.48.V	719	203	365	220	290	145
AP80.80.48.V.Ex	719	203	365	220	290	145
AP80.80.65/2.V	719	203	365	220	290	145
AP80.80.65/2.V.Ex	719	203	365	220	290	145
AP80.80.65/1.V	719	203	365	220	290	145
AP80.80.65/1.V.Ex	719	203	365	220	290	145
AP80.80.92/2.V	789	203	365	220	290	145
AP80.80.92/2.V.Ex	789	203	365	220	290	145
AP80.80.92/1.V	789	203	365	220	290	145
AP80.80.92/1.V.Ex	789	203	365	220	290	145
AP80.80.107.V	789	203	365	220	290	145
AP80.80.107.V.Ex	789	203	365	220	290	145
AP80.100.48.V	719	213	385	240	290	145
AP80.100.48.V.Ex	719	213	385	240	290	145
AP80.100.65/2.V	719	213	385	240	290	145
AP80.100.65/2.V.Ex	719	213	385	240	290	145
AP80.100.65/1.V	719	213	385	240	290	145
AP80.100.65/1.V.Ex	719	213	385	240	290	145
AP80.100.92/2.V	789	213	385	240	290	145
AP80.100.92/2.V.Ex	789	213	385	240	290	145
AP80.100.92/1.V	789	213	385	240	290	145
AP80.100.92/1.V.Ex	789	213	385	240	290	145
AP80.100.107.V	789	213	385	240	290	145
AP80.100.107.V.Ex	789	213	385	240	290	145

## Weights

Pump type	Standard pumps [kg]				Explosion-proof pumps [kg]			
	Without moisture sensor	With moisture sensor	Vertical dry installation (D)	Horizontal dry installation (DH)	Without moisture sensor	With moisture sensor	Vertical dry installation (D)	Horizontal dry installation (DH)
AP80.80.48.V(Ex)	104	106	109	119	104	106	109	119
AP80.80.65/1.V(Ex)	107	109	112	122	107	109	112	122
AP80.80.65/2.V(Ex)	108	110	113	123	108	110	113	123
AP80.80.92/1.V(Ex)	113	115	119	129	113	115	119	129
AP80.80.92/2.V(Ex)	114	116	120	130	114	116	120	130
AP80.80.107.V(Ex)	117	119	123	133	117	119	123	133
AP80.100.48.V(Ex)	106	108	111	121	106	108	111	121
AP80.100.65/1.V(Ex)	109	111	114	124	109	111	114	124
AP80.100.65/2.V(Ex)	110	112	115	125	110	112	115	125
AP80.100.92/1.V(Ex)	115	117	121	131	115	117	121	131
AP80.100.92/2.V(Ex)	116	118	122	132	116	118	122	132
AP80.100.107.V(Ex)	119	121	125	135	119	121	125	135

## Electrical data

Pump type	Voltage	P <sub>1</sub> [kW]	P <sub>2</sub> [kW]	n [min <sup>-1</sup> ]	I <sub>n</sub> [A]	Cos φ	$\frac{I_{start}}{I_n}$
AP80.80.10.V(Ex)	3 x 400 V	1.4	1.0	1450	2.7	0.75	6.0
AP80.80.13.V(Ex)	3 x 400 V	1.7	1.3	1450	3.3	0.77	6.0
AP80.80.20.V(Ex)	3 x 400 V	2.7	2.0	1450	5.2	0.76	6.0
AP80.80.26.V(Ex)	3 x 400 V	3.4	2.4	1450	6.3	0.80	4.3
AP80.80.48.V(Ex)	3 x 400 V	6.0	4.8	2900	10.0	0.80	7.9
AP80.80.65/1.V(Ex)	3 x 400 V	7.5	6.5	2900	13.0	0.84	6.1
AP80.80.65/2.V(Ex)	3 x 400 V	7.5	6.5	2900	13.0	0.84	6.1
AP80.80.92/1.V(Ex)	3 x 400 V	11.0	9.2	2900	18.8	0.78	6.2
AP80.80.92/2.V(Ex)	3 x 400 V	11.0	9.2	2900	18.8	0.85	6.2
AP80.80.107.V(Ex)	3 x 400 V	13.0	10.7	2900	22.2	0.85	6.2
AP80.100.48.V(Ex)	3 x 400 V	6.0	4.8	2900	10.0	0.80	7.9
AP80.100.65/1.V(Ex)	3 x 400 V	7.5	6.5	2900	13.0	0.84	6.1
AP80.100.65/2.V(Ex)	3 x 400 V	7.5	6.5	2900	13.0	0.84	6.1
AP80.100.92/1.V(Ex)	3 x 400 V	11.0	9.2	2900	18.8	0.85	6.2
AP80.100.92/2.V(Ex)	3 x 400 V	11.0	9.2	2900	18.8	0.85	6.2
AP80.100.107.V(Ex)	3 x 400 V	13.0	10.7	2900	22.0	0.85	6.2



## AP100

The pumps are used for pumping sewage, wastewater, considerable quantities of surface water and ground water in places such as

- municipal pump pits,
- public buildings,
- block of flats,
- factories,
- garages,
- underground car-parks,
- car wash areas,
- restaurants and
- hotels.

## Pump and stator housing

The pump housing and the stator housing are made of cast iron.

The stator housing is dry, i.e. not oil-filled.

## Discharge

All AP100 pumps have a horizontal discharge port.

AP100.100 have a DN 100 DIN flange.

AP100.150 have a DN 150 DIN flange.

## Shaft and bearings

The shaft is made of stainless steel and rotates in maintenance-free prelubricated ball bearings.

The lower bearing is a double-row ball bearings.

## Impeller

The impeller is a closed single-channel or two-channel cast iron impeller with a clearance of 100 mm. Cast iron is chosen as it is resistant towards mechanically wearing particles.

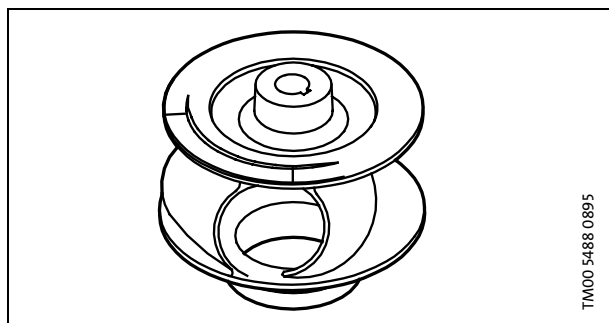

The inlet side of the pump housing is fitted with a replaceable neck ring.

## Shaft seal

Two mechanical bellows seals with silicon carbide/silicon carbide seal faces.

An oil chamber between the primary and the secondary shaft seal is filled with oil.

Pump type	Oil volume
AP100.100.24 - 61	1.7 litres
AP100.100.80 - 135	3 litres
AP100.150.80 - 170	3 litres

## Motor cable

Standard pumps 10 m: H07RNF.

Ex-pumps 10 m: H07RNF - PLUS.

## Materials

Description	Materials	DIN W.-Nr.	AISI/ASTM
Stator housing	Cast iron EN-GJL-250	0.6025	ASTM 35B
Pump housing	Cast iron EN-GJL-250	0.6025	ASTM 35B
Neck ring	Bronze		
Impeller	Cast iron EN-GJL-250	0.6025	ASTM 35B
Shaft	Stainless steel	1.4104	AISI 430F
Bearings	Heavy-duty prelubricated ball bearings		
Screws	Stainless steel	1.4301	AISI 304
Cooling jacket	Stainless steel	1.4301	AISI 304
Oil	Shell Ondina 15, non-toxic		

## Cooling jacket

On request all AP100 pumps can be supplied fitted with a stainless steel cooling jacket.

Liquid temperature with cooling jacket: 0°C to +40°C. For short periods, max. one hour: Up to +60°C. For periods longer than one hour, external cooling is required.

The cooling jacket is available for internal as well as external cooling of the motor in both dry and submerged installations.

Internal cooling (standard) is achieved by leading part of the pumped liquid around the stator housing and back to the pump housing via internal channels.

For external cooling the cooling jacket is fitted with sockets for pipe connections.

The cooling jacket is required for cooling of the motor in dry installations, and in submerged installations if the pump is not completely submerged during continuous operation.

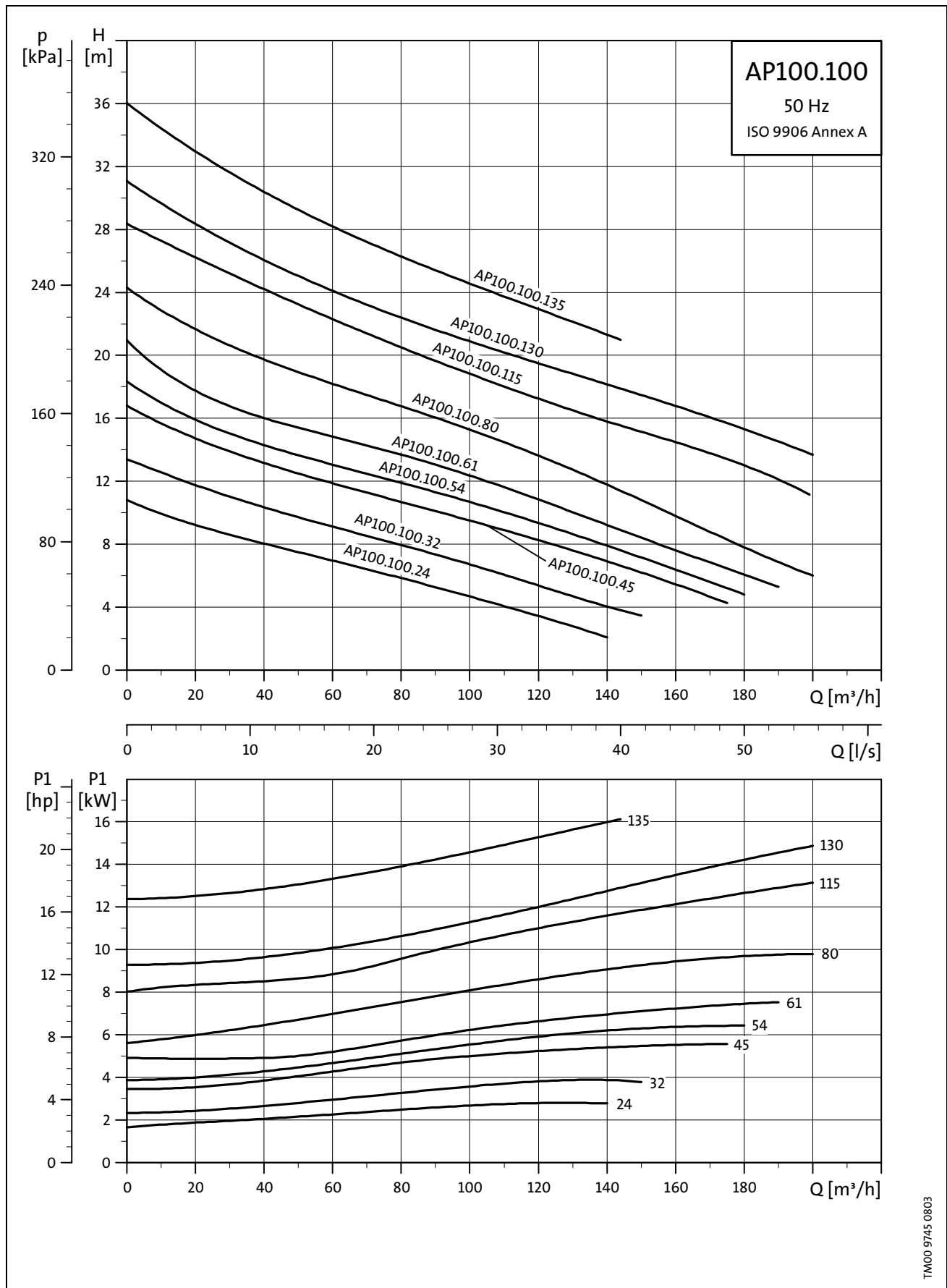

TM00 9745 0803

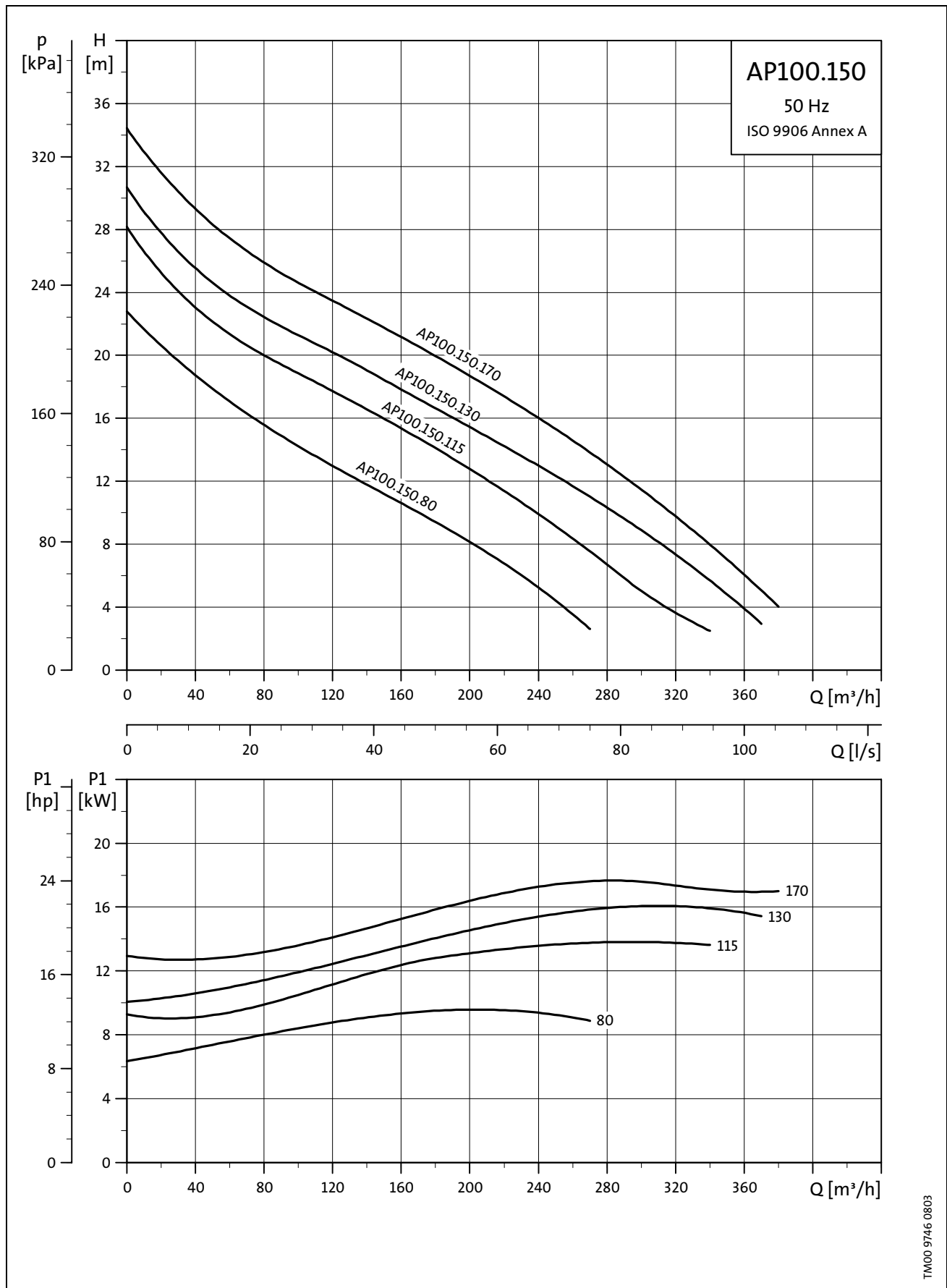

TM00 9746 0803

## One-pump installation on auto-coupling

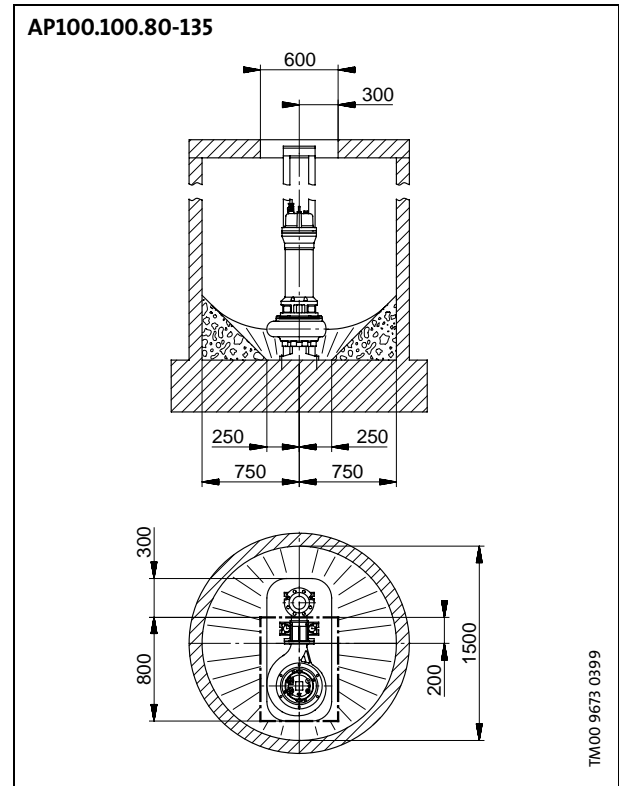
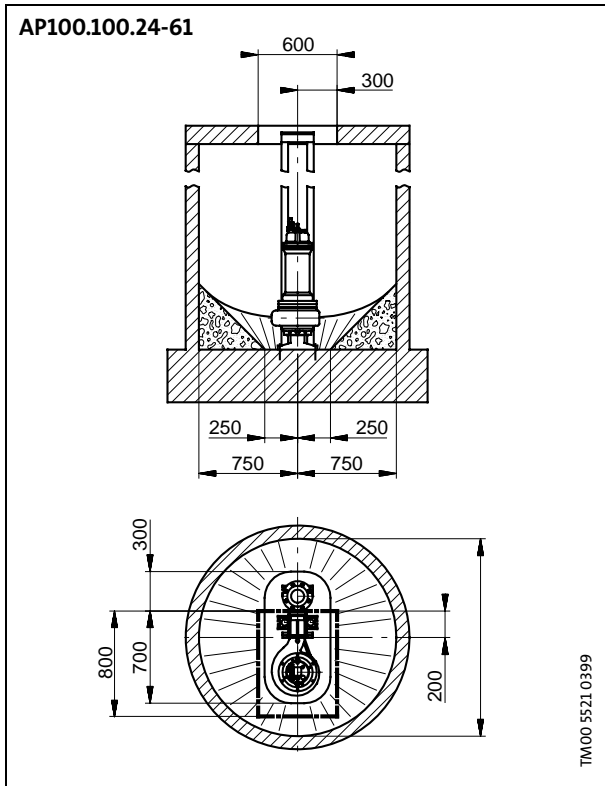

## Two-pump installation on auto-coupling

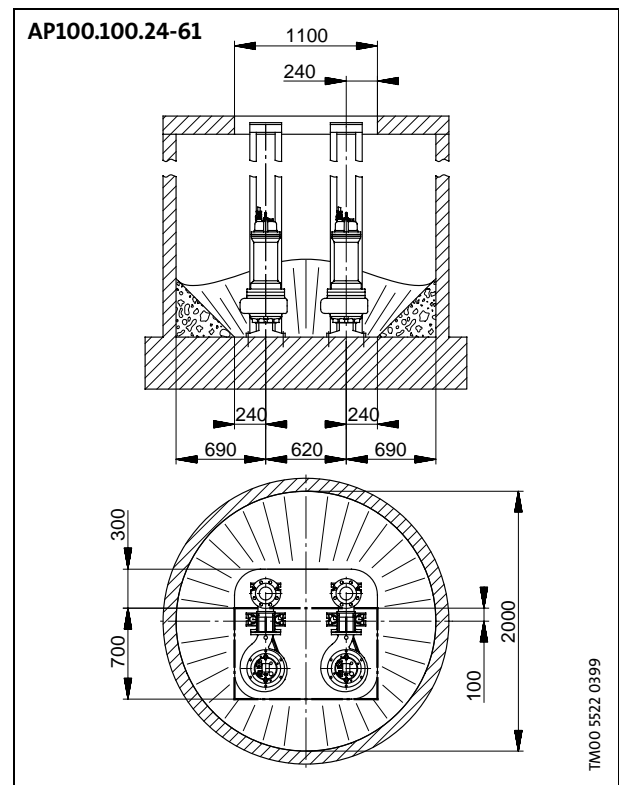
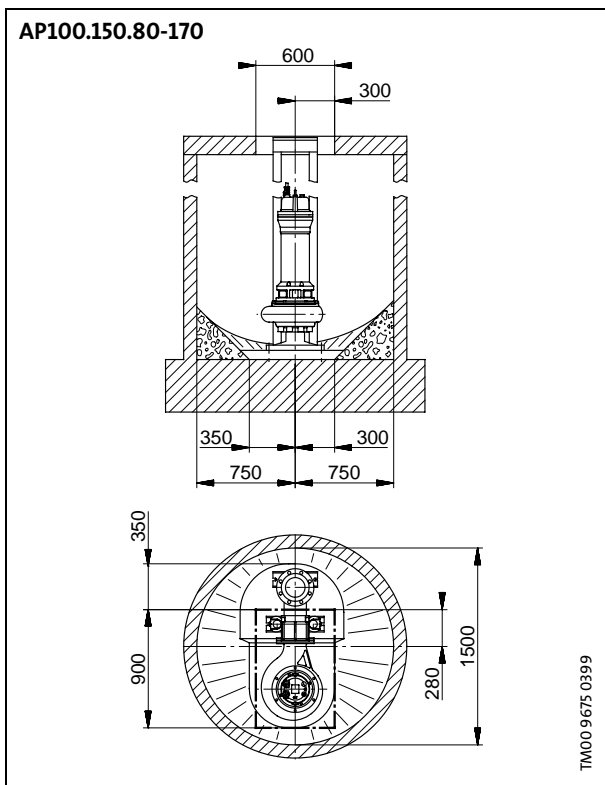

## Two-pump installation on auto-coupling

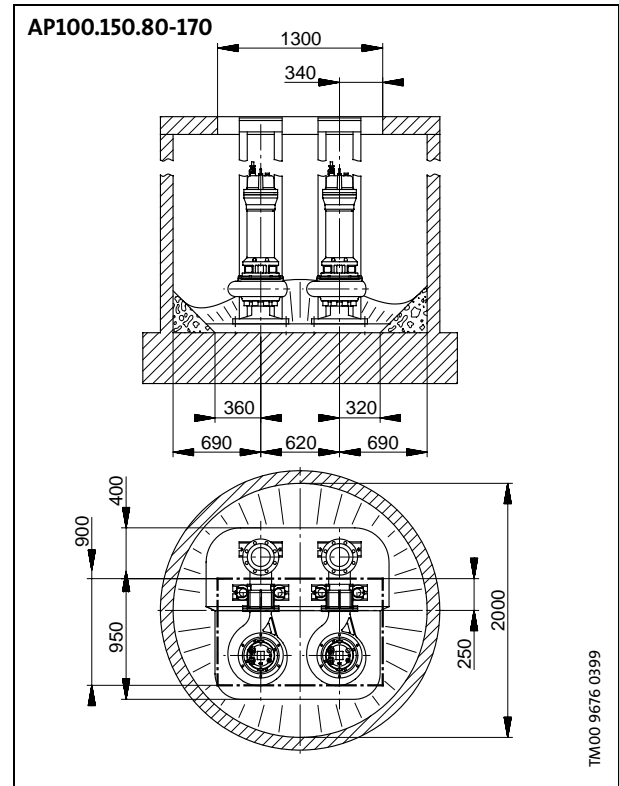
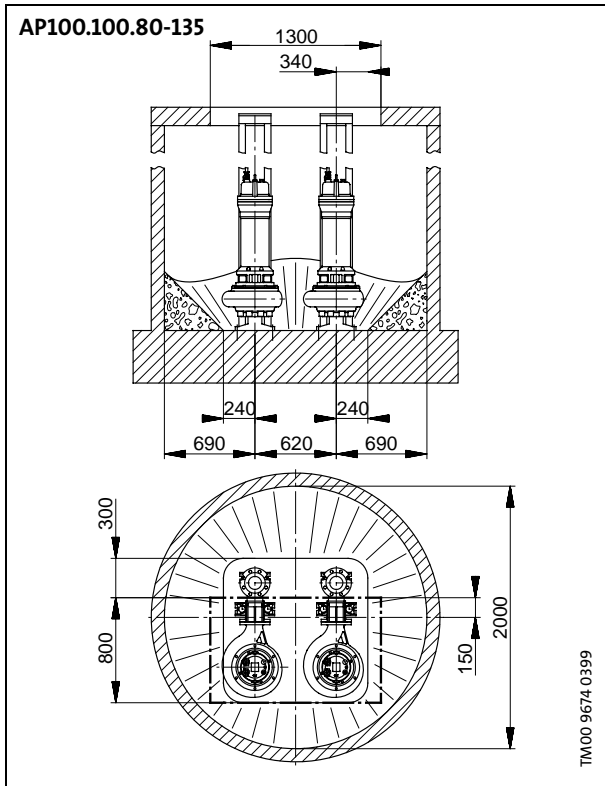

## DN 100 auto-coupling

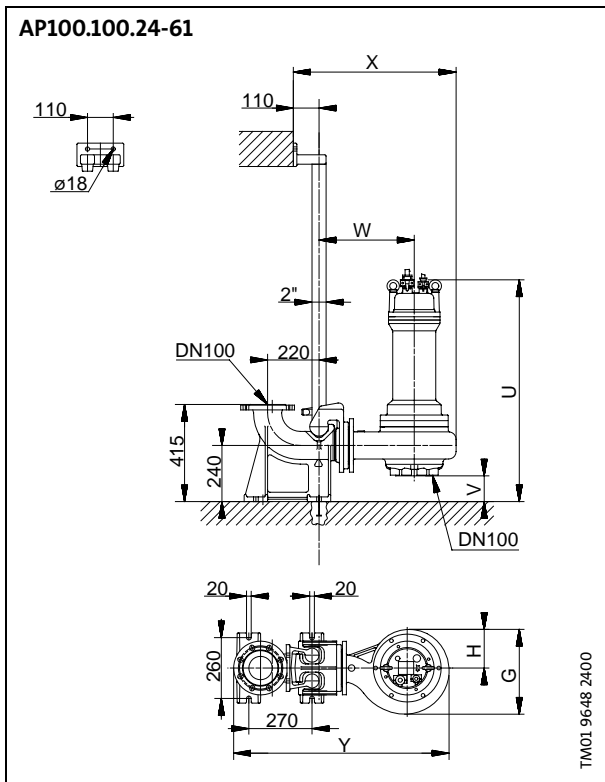

## DN 100 auto-coupling

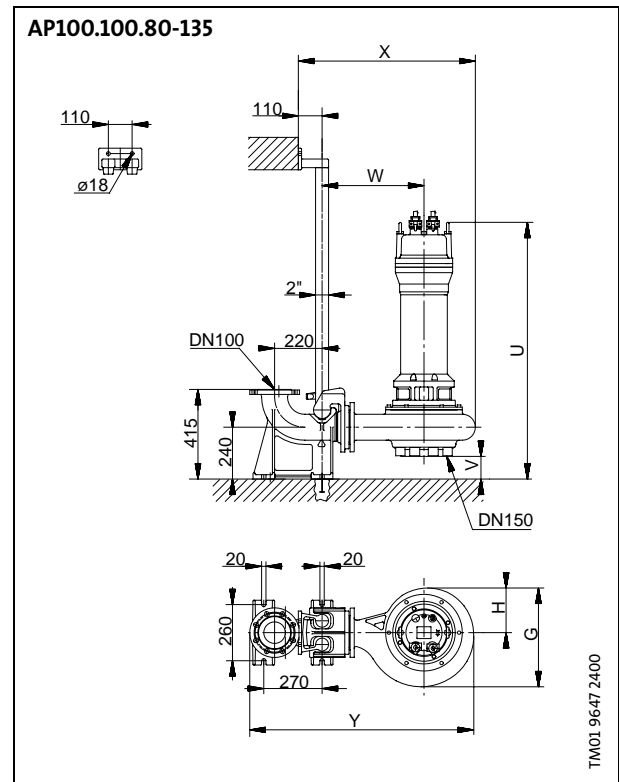

## DN 150 auto-coupling

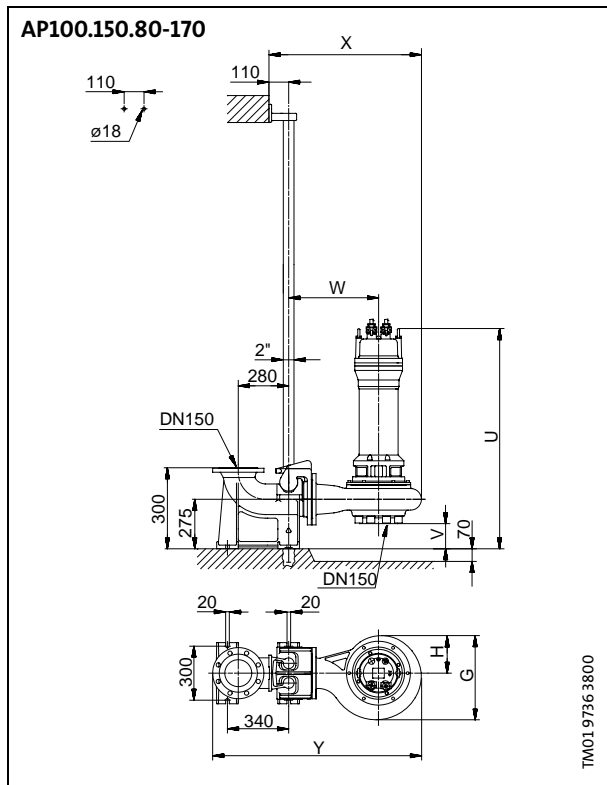

## Dimensions for installation on auto-coupling DN 100

Pump type	Dimensions [mm]						
	G	H	U	V	W	X	Y
AP100.100.24	323	147	889	117	362	606	834
AP100.100.24.Ex	323	147	889	117	362	606	834
AP100.100.32	323	147	889	117	362	606	834
AP100.100.32.Ex	323	147	889	117	362	606	834
Ap100.100.45	363	165	948	110	377	643	871
Ap100.100.45.Ex	363	165	948	110	377	643	871
AP100.100.54	363	165	948	110	377	643	871
AP100.100.54.Ex	363	165	948	110	377	643	871
AP100.100.61	363	165	948	110	377	643	871
AP100.100.61.Ex	363	165	948	110	377	643	871
AP100.100.80	457	206	1039	105	442	767	988
AP100.100.80.Ex	457	206	1039	105	442	767	988
AP100.100.115	457	206	1099	105	442	767	988
AP100.100.115.Ex	457	206	1099	105	442	767	988
AP100.100.130	457	206	1099	105	442	767	988
AP100.100.130.Ex	457	206	1099	105	442	767	988
AP100.100.135	457	206	1099	105	442	767	988
AP100.100.135.Ex	457	206	1099	105	442	767	988

## Dimensions for installation on auto-coupling DN 150

Pump type	Dimensions [mm]						
	G	H	U	V	W	X	Y
AP100.150.80	468	209	1074	140	495	843	1158
AP100.150.80.Ex	468	209	1074	140	495	843	1158
AP100.150.115	468	209	1134	140	495	843	1158
AP100.150.115.Ex	468	209	1134	140	495	843	1158
AP100.150.130	468	209	1134	140	495	843	1158
AP100.150.130.Ex	468	209	1134	140	495	843	1158
AP100.150.170	468	209	1224	140	495	843	1158
AP100.150.170.Ex	468	209	1224	140	495	843	1158

## Vertical dry installation (D)

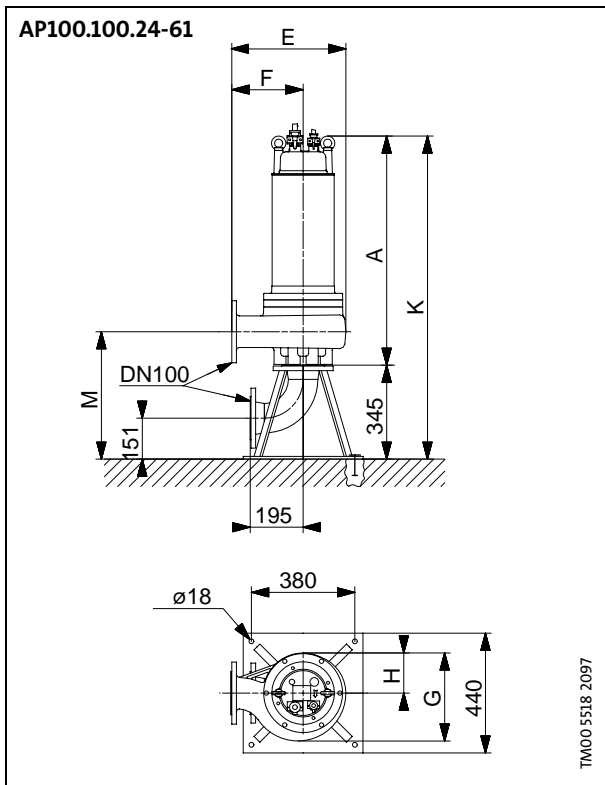

## Vertical dry installation (D)

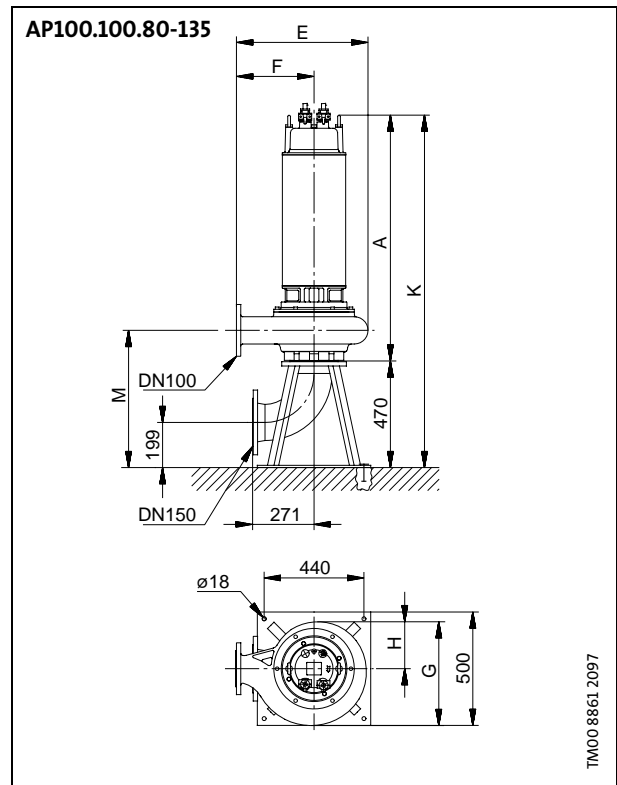

## Vertical dry installation (D)

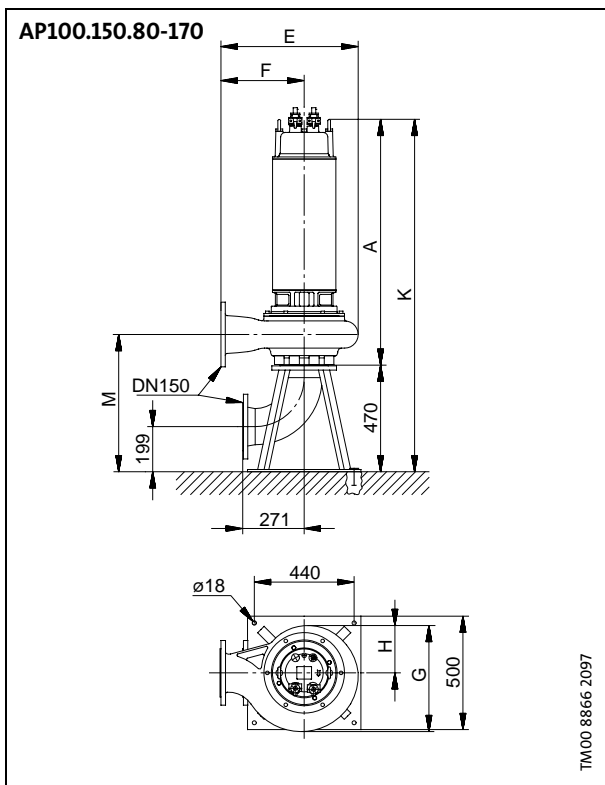



## Dimensions for vertical dry installation (D)

Pump type	Dimensions [mm]						
	A	E	F	G	H	K	M
AP100.100.24.(Ex)	772	422	265	323	147	1117	468
AP100.100.32.(Ex)	772	422	265	323	147	1117	468
AP100.100.45.(Ex)	838	459	280	363	165	1183	475
AP100.100.54.(Ex)	838	459	280	363	165	1183	475
AP100.100.61.(Ex)	838	459	280	363	165	1183	475
AP100.100.80.(Ex)	934	583	345	457	206	1404	605
Ap100.100.115.(Ex)	994	583	345	457	206	1464	605
AP100.100.130.(Ex)	994	583	345	457	206	1464	605
AP100.100.135.(Ex)	994	583	345	457	206	1464	605
AP100.150.80.(Ex)	934	608	370	468	209	1404	605
AP100.150.115.(Ex)	994	608	370	468	209	1464	605
AP100.150.130.(Ex)	994	608	370	468	209	1464	605
AP100.150.170.(Ex)	1084	608	370	468	209	1554	605

## Horizontal dry installation (DH)

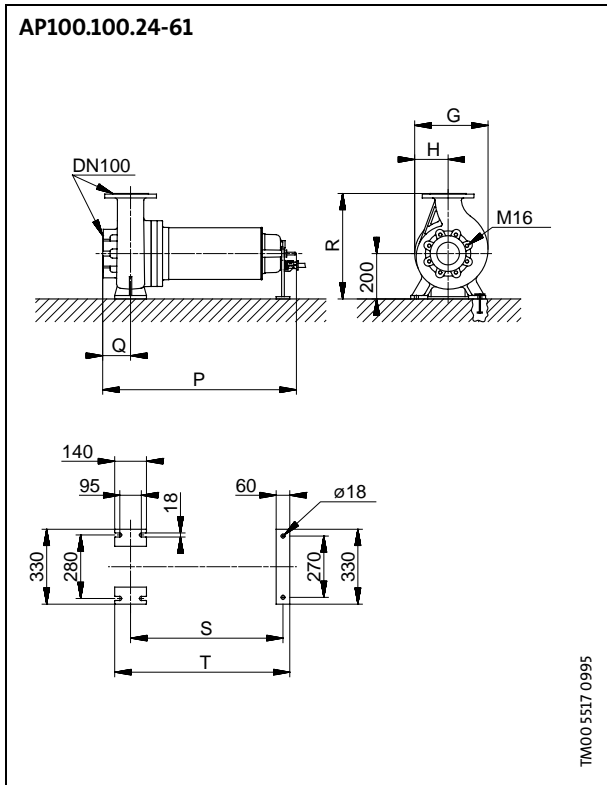

## Horizontal dry installation (DH)

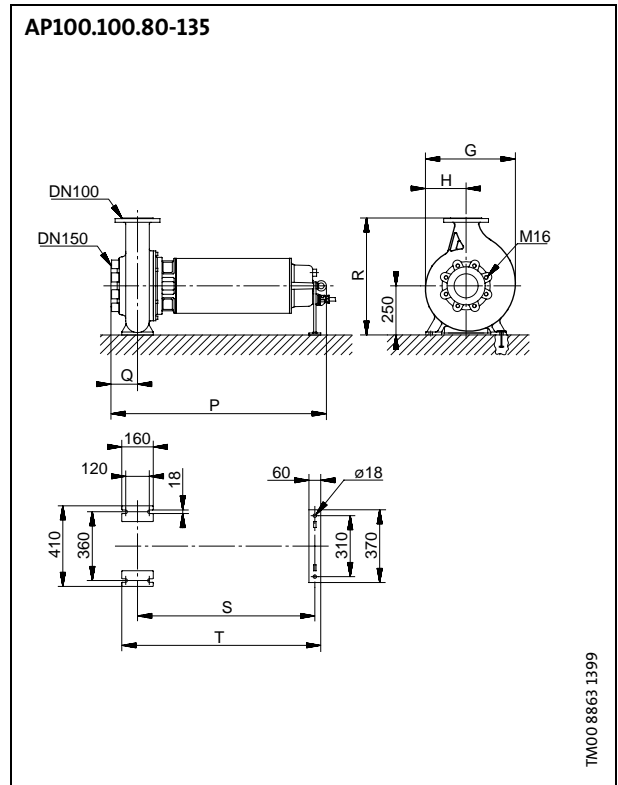

## Horizontal dry installation (DH)

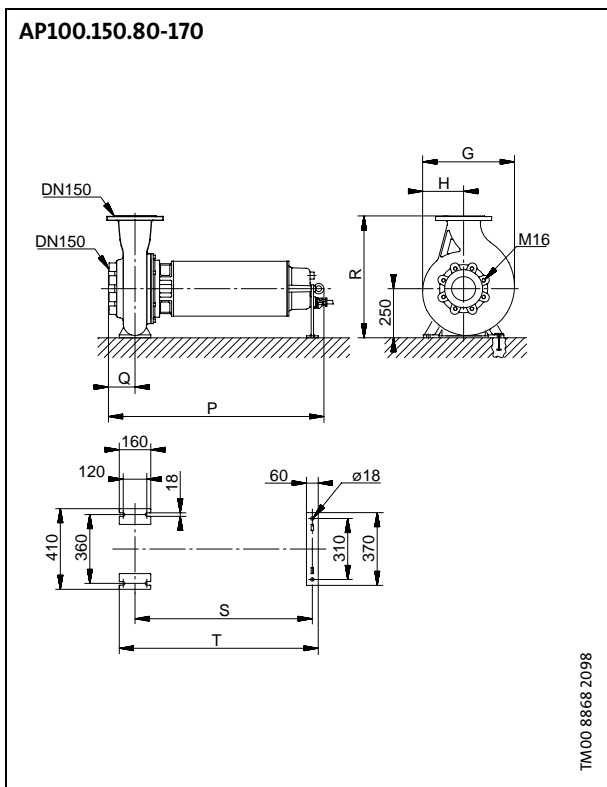

## Dimensions for horizontal dry installation (DH)

Pump type	Dimensions [mm]						
	G	H	P	Q	R	S	T
AP100.100.24.(Ex)	323	147	784	123	465	602	700
AP100.100.32.(Ex)	323	147	784	123	465	602	700
AP100.100.45.(Ex)	363	165	850	130	480	661	761
AP100.100.54.(Ex)	363	165	850	130	480	661	761
AP100.100.61.(Ex)	363	165	850	130	480	661	761
AP100.100.80.(Ex)	457	206	946	135	595	752	862
AP100.100.115.(Ex)	457	206	1006	135	595	812	922
AP100.100.130.(Ex)	457	206	1006	135	595	812	922
AP100.100.135.(Ex)	457	206	1006	135	595	812	922
AP100.150.80.(Ex)	468	209	946	135	620	752	862
AP100.150.115.(Ex)	468	209	1006	135	620	812	922
AP100.150.130.(Ex)	468	209	1006	135	620	812	922
AP100.150.170.(Ex)	468	209	1096	135	620	902	1012

## Submerged free-standing installation

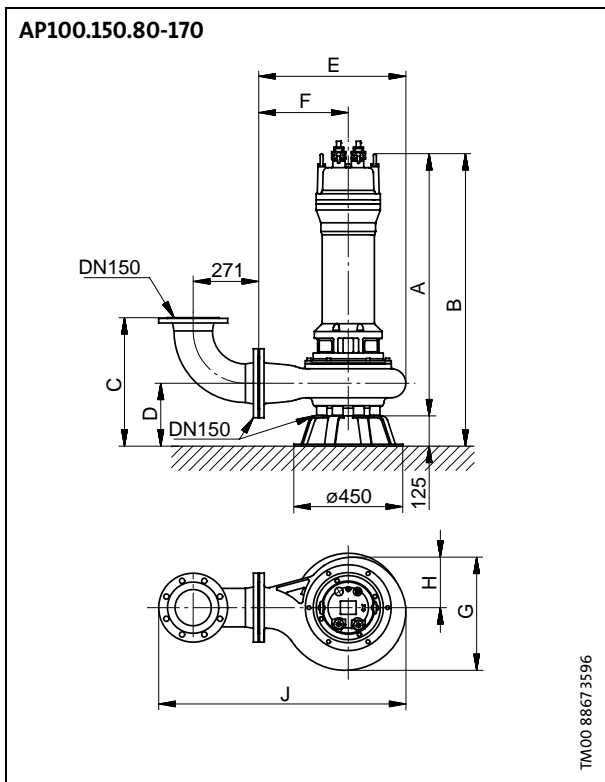
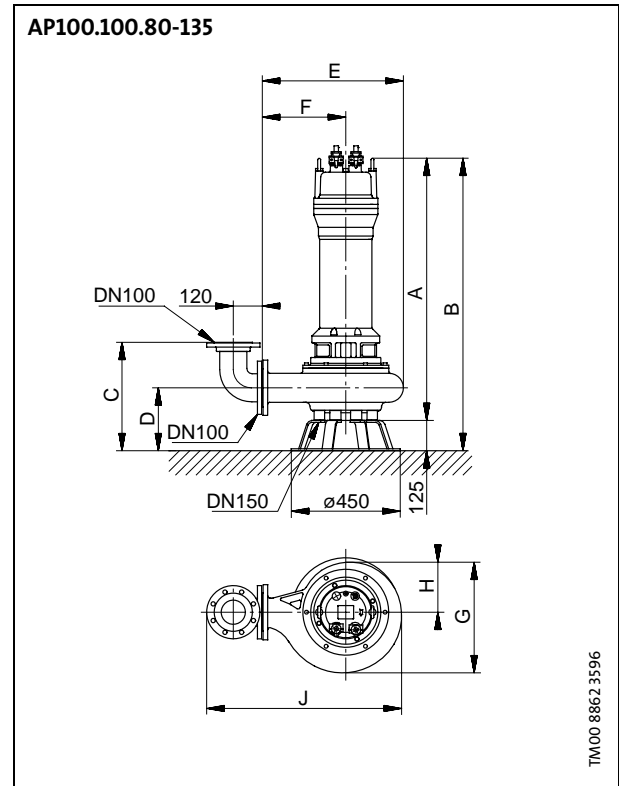
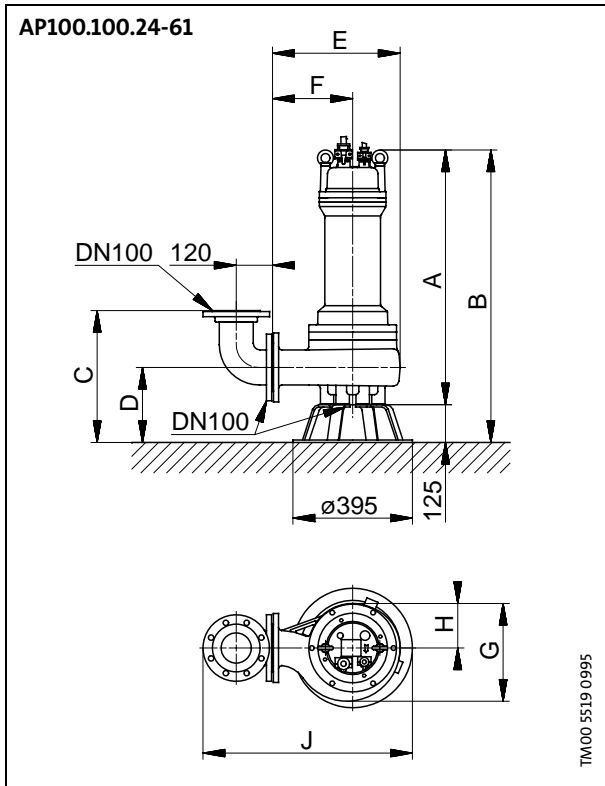

## Dimensions for submerged free-standing installation

Pump type	Dimensions [mm]								
	A	B	C	D	E	F	G	H	J
AP100.100.24.(Ex)	772	897	436	248	422	265	323	147	693
AP100.100.32.(Ex)	772	897	436	248	422	265	323	147	693
AP100.100.45.(Ex)	838	963	443	255	459	280	363	165	708
AP100.100.54.(Ex)	838	963	443	255	459	280	363	165	708
AP100.100.61.(Ex)	838	963	443	255	459	280	363	165	708
AP100.100.80.(Ex)	934	1059	448	260	583	345	457	206	806
AP100.100.115.(Ex)	994	1119	448	260	583	345	457	206	806
AP100.100.130.(Ex)	994	1119	448	260	583	345	457	206	806
AP100.100.135.(Ex)	994	1119	448	260	583	345	457	206	806
AP100.150.80.(Ex)	934	1059	531	280	608	370	468	209	1022
AP100.150.115.(Ex)	994	1119	531	280	608	370	468	209	1022
AP100.150.130.(Ex)	994	1119	531	280	608	370	468	209	1022
AP100.150.170.(Ex)	1084	1209	531	280	608	370	468	209	1022

## Weights

Pump type	Standard pumps [kg]				Explosion-proof pumps [kg]			
	Without moisture sensor	With moisture sensor	Vertical dry installation (D)	Horizontal dry installation (DH)	Without moisture sensor	With moisture sensor	Vertical dry installation (D)	Horizontal dry installation (DH)
AP100.100.24	116	118	121	123	117	120	121	123
AP100.100.32	120	123	124	126	121	124	126	128
AP100.100.45	123	126	129	131	124	127	131	133
AP100.100.54	127	130	133	135	128	131	134	136
AP100.100.61	127	130	133	135	128	131	134	136
AP100.100.80	192	196	203	203	193	197	205	205
AP100.100.115	214	218	226	226	215	219	228	228
AP100.100.130	216	220	228	228	217	221	230	230
AP100.100.135	218	222	230	230	219	223	232	232
AP100.150.80	198	202	211	211	199	203	213	213
AP100.150.115	220	224	234	234	221	225	236	236
AP100.150.130	222	226	236	236	222	227	238	238
AP100.150.170	235	239	249	249	236	240	251	251

## Electrical data

Pump type	Voltage	P <sub>1</sub> [kW]	P <sub>2</sub> [kW]	n [min <sup>-1</sup> ]	I <sub>n</sub> [A]	Cos φ	$\frac{I_{start}}{I_n}$
AP100.100.24.(Ex)	3 x 400 V	3.00	2.40	1450	5.9	0.79	6.2
AP100.100.32.(Ex)	3 x 400 V	4.00	3.20	1450	7.5	0.84	6.0
AP100.100.45.(Ex)	3 x 400 V	5.50	4.50	1450	10.6	0.84	6.0
AP100.100.54.(Ex)	3 x 400 V	6.50	5.40	1450	12.0	0.84	6.4
AP100.100.61.(Ex)	3 x 400 V	7.50	6.10	1450	13.6	0.83	5.7
AP100.100.80.(Ex)	3 x 400 V	10.0	8.00	1450	17.5	0.83	4.3
AP100.100.115.(Ex)	3 x 400 V	14.0	11.5	1450	25.0	0.81	3.6
AP100.100.130.(Ex)	3 x 400 V	16.5	13.0	1450	30.0	0.87	3.5
AP100.100.135.(Ex)	3 x 400 V	17.0	13.5	1450	36.0	0.82	5.3
AP100.150.80.(Ex)	3 x 400 V	10.0	8.00	1450	17.5	0.83	4.3
AP100.150.115.(Ex)	3 x 400 V	14.0	11.5	1450	25.0	0.81	3.6
AP100.150.130.(Ex)	3 x 400 V	16.5	13.0	1450	30.0	0.87	3.5
AP100.150.170.(Ex)	3 x 400 V	20.0	17.0	1450	36.0	0.82	4.3

### Vertical dry installation (D)

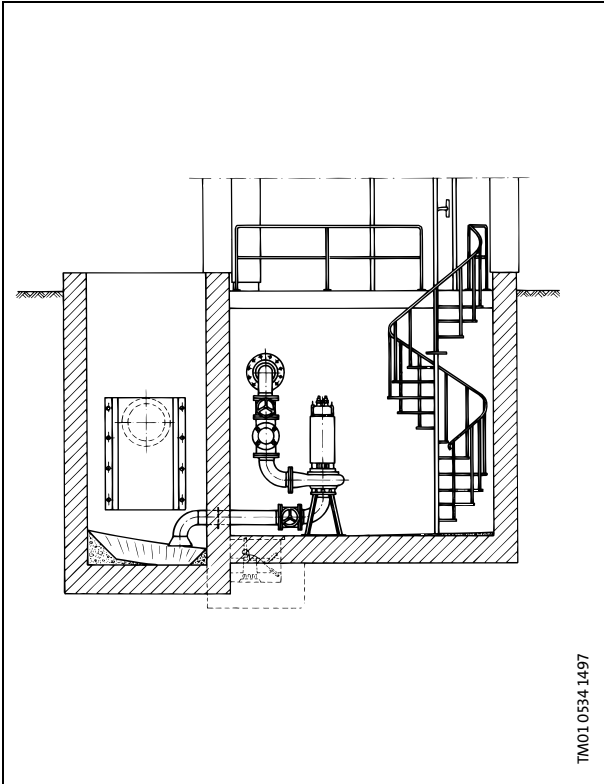

### Horizontal dry installation (DH)

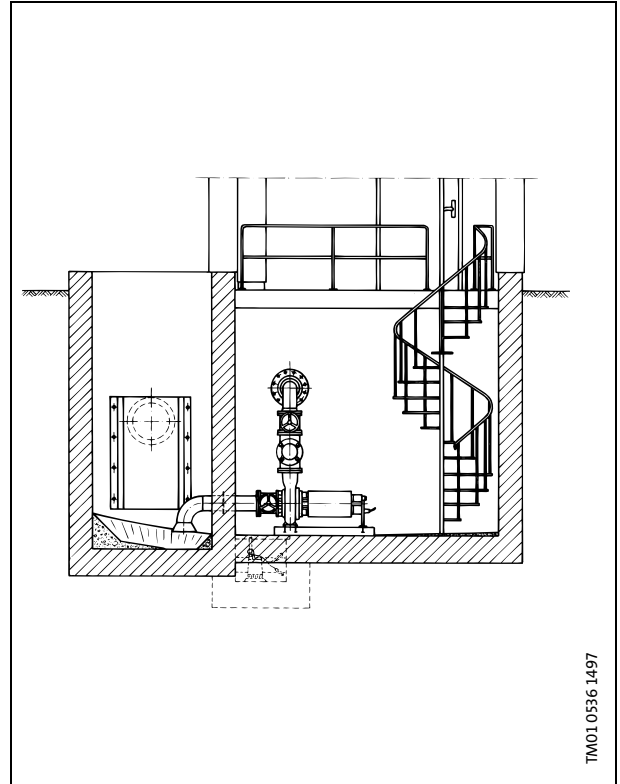

### Vertical dry installation (D)

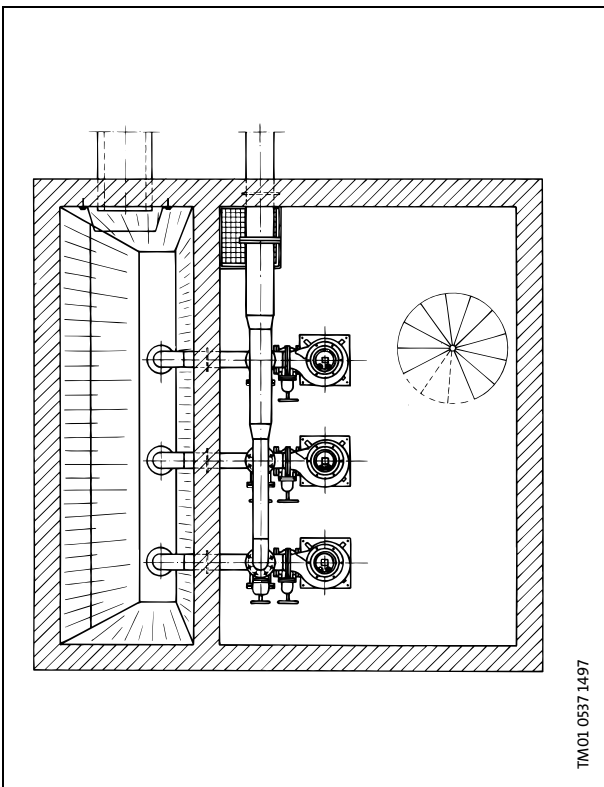

### Horizontal dry installation (DH)

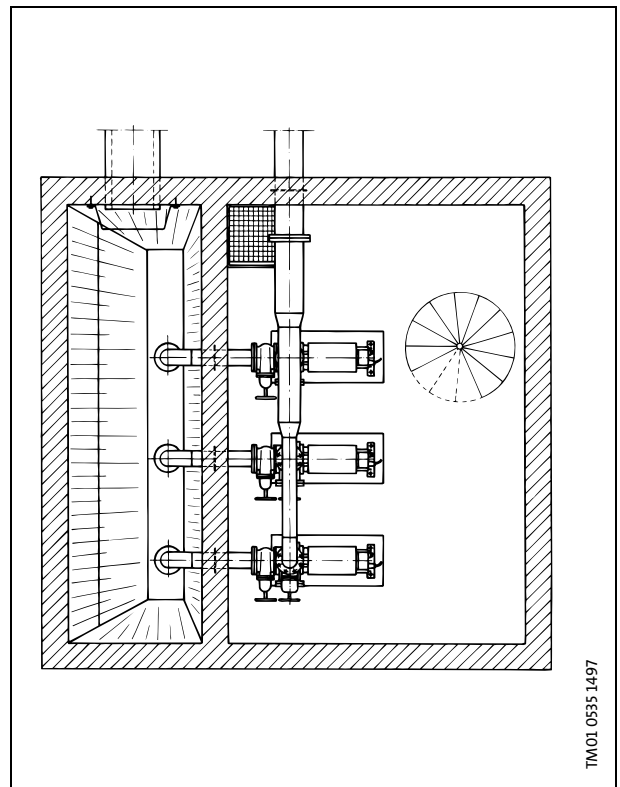

## LC 107, LCD 107

The LC 107 and LCD 107 pump controllers are designed for level control, monitoring and protection of Grundfos KP, AP and APG pumping systems up to 23 A/11 kW (P<sub>1</sub>) per pump starting direct-on-line.

- LC 107 is a one-pump controller.
- LCD 107 is a two-pump controller.

LC 107 and LCD 107 are supplied as a complete controller incorporating motor protection relay, bell-shaped level pickups, pneumatic tubes and control unit.

Control is based on pneumatic signals which the LC 107 and LCD 107 receive via pneumatic tubes from 2 or 3 level pickups positioned in a pump pit.

The LC 107 and LCD 107 enable:

- control of 1 or 2 pumps based on signals from bell-shaped level pickups,
- automatic pump changeover (even distribution of operating hours on both pumps),
- selection of automatic test run every 24 hours during long periods of inactivity to prevent the shaft from seizing up,
- protection against water hammer as quick restart/simultaneous start is blocked and delayed,
- battery back-up in case of mains supply failure (accessory!),
- starting delay within the range from 0 to 255 sec. (random) after returning from battery operation to mains operation (resulting in an even mains load when several pumping stations are started up at the same time),
- selection of automatic alarm resetting,
- selection of automatic restarting,
- setting of stop delays matching the actual operating conditions,
- indication of liquid level,
- alarm indication of:
  - too high liquid level, which triggers a high-level alarm,
  - overload (via motor protection relay),
  - overtemperature (via PTC resistance/thermal switch in motor),
  - wrong phase sequence,
  - mains supply failure,
  - failing level pickup.

As standard, the LC 107 and LCD 107 have two alarm signal outputs:

- common alarm,
- high-level alarm.

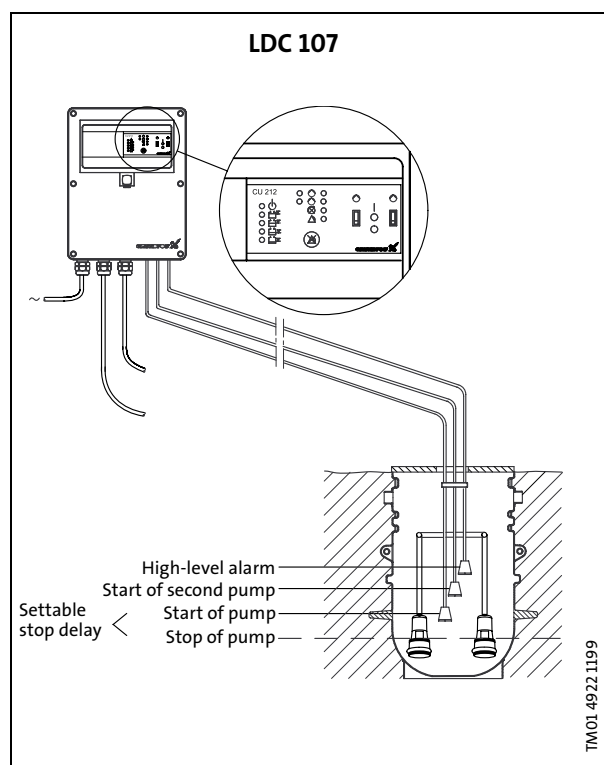
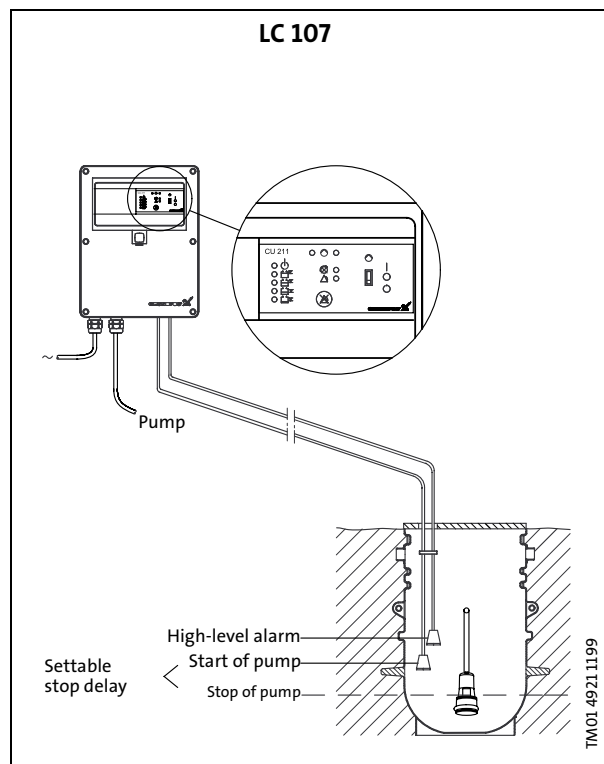

## Technical data LC 107, LCD 107

### Voltage tolerances

-15%/+10% of nominal voltage.

### Mains frequency

50/60 Hz.

### Ambient temperature

- During operation: -30°C to +50°C (must not be exposed to direct sunlight).
- In stock: -30°C to +60°C.

### Enclosure class

IP 55.

### Pneumatic tubes

- Maximum 20 m per tube (standard: pneumatic tube of 10 metres).
- Diameter: 10 mm.
- Material: PA 11.

### Outputs for alarm devices

Max. 400 VAC / max. 2 A / min. 10 mA / AC 1.

## LC 108, LCD 108

The LC 108 and LCD 108 pump controllers are designed for level control, monitoring and protection of pumps in wastewater, water supply and drainage systems.

Up to 23 A/11 kW (P<sub>1</sub>) starting direct-on-line (DOL).  
Up to 72 A/30 kW (P<sub>1</sub>) starting star-delta (Y/D).

- LC 108 is a one-pump controller
- LCD 108 is a two-pump controller

The LC 108 and LCD 108 are supplied as complete controllers incorporating motor protection relay and control unit.

### The LC 108 enables:

- control of 1 or 2 pumps based on signals from float switches, electrodes or flow switches,
- selection of automatic test run (every 24 hours) during long periods of inactivity to prevent the shaft from seizing up,
- protection against water hammer as quick restart is blocked and delayed (5 seconds),
- selection of automatic alarm resetting,
- selection of automatic restarting (after overtemperature),
- setting of stop delays matching the actual operating conditions,
- indication of liquid level,
- alarm indication of:
  - wrong phase sequence,
  - inadmissibly high liquid level,
  - overload (via motor protection relay),

- overtemperature (via PTC resistance or thermal switch in motor),
- defective float switch, electrode or flow switch,
- dry running,
- mains supply failure (by installing a battery back-up which is available as an accessory).
- automatic pump changeover (even distribution of operating hours on both pumps). (LCD 108 only).

As standard, the LC 108 and LCD 108 controllers incorporate a buzzer for indication of alarm.

Furthermore, the controller has one alarm output for common alarm.

### Applications

The LC 108 and LCD 108 can be connected and set to operation/control in 7 different ways:

- systems with 2 float switches,
- systems with 3 float switches,
- systems with 4 float switches,
- systems with 2 electrodes,
- systems with 3 electrodes,
- systems for filling applications,
- systems for drainage applications.

## Technical data LC 108, LCD 108

### Voltage tolerances

-15%/+10% of nominal voltage.

### Mains frequency

50/60 Hz.

### Ambient temperature

- During operation: -30°C to +50°C (must not be exposed to direct sunlight).
- In stock: -30°C to +60°C.

### Enclosure class

IP 55.

### Outputs for alarm devices

Max. 400 VAC / max. 2 A / min. 10 mA / AC 1.

### Supply system earthing

For TN systems and TT systems.

### Rated insulation voltage, U<sub>i</sub>

4 kV.

### Rated impulse withstand voltage, U<sub>imp</sub>

4 kV.

### EMC (electromagnetic compatibility)

According to EN 50 081-1 and EN 50 082-2.



## Dimensions

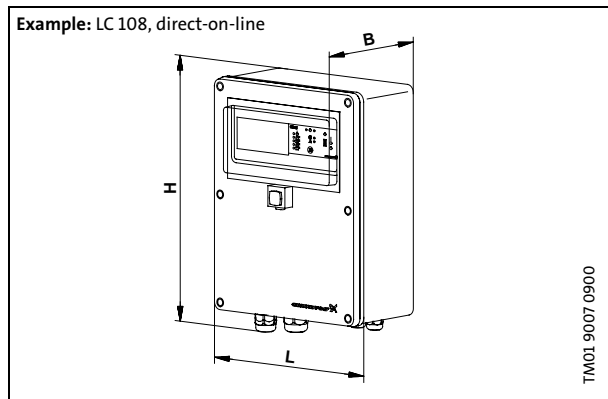

Type	Dimensions [mm]		
	H	L	B
LC 107, direct-on-line LCD 107, direct-on-line	350	250	136
LC 108, direct-on-line LCD 108, direct-on-line	350	250	136
LC 108, Star/delta	590	380	200
LCD 108, Star/delta	635	500	220

## Level switches

The AP pumps in combination with LC 108 or LCD 108 are available with level switches for automatic level control. Level switches supplied by Grundfos are of the non-mercury type.

LC 108 can be fitted with up to three level switches:

1. Min.: Stops the pump.
2. Max.: Starts the pump.
3. Alarm: Alarm (optional): high water level or pump fault.

LCD 108 can be fitted with up to four level switches:

1. Min.: Stops both pumps.
2. Max. 1: Starts one pump.
3. Max. 2: Starts the other pump.
4. Alarm: Alarm (optional): high water level or pump fault.

The level switches are to be installed in the pit floating on the pumped liquid.

The position of the level switches decides when LC 108 or LCD 108 starts and stops the AP pumps:

- When the level switch is pointing upwards, the level switch contact will be closed and the pump will start.
- When the level switch is pointing downwards, the level switch contact will be opened and the pump will stop.

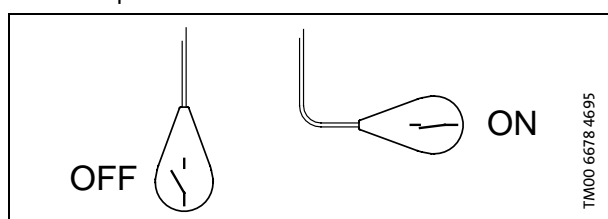

## Explosion protection unit, LC Ex 4

For pumps installed in explosive environments, an Ex barrier type LC-Ex 4 is required between the LC 108, LCD 108 and the level switches.

The Zener barrier ensures that the signals to/from the LC 108 or LCD 108 do not present any form of risk when entering the potentially explosive environment, even if the worst possible faults occur on the LC 108 or LCD 108.

**Note:** The LC-Ex 4 and the LC 108 or LCD 108 must not be installed in explosive environments.

The connections to the LC-Ex 4 and the LC 108 or LCD 108 are similar using the same connection numbers.

No change to the LC 108 or LCD 108 is necessary when using the LC-Ex 4. All settings involving level switches are the same as before.

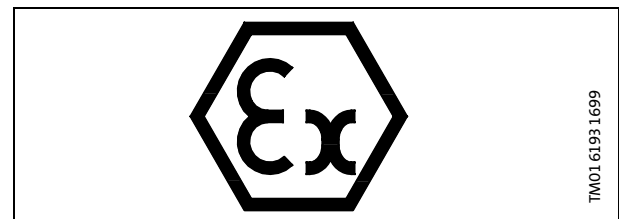

## Technical data

$U_m$	250 VAC
$U_o$	8.2 V
$I_o$	370 mA
$C_o$	2 $\mu$ F
$L_o$	50 $\mu$ H

## Dimensions

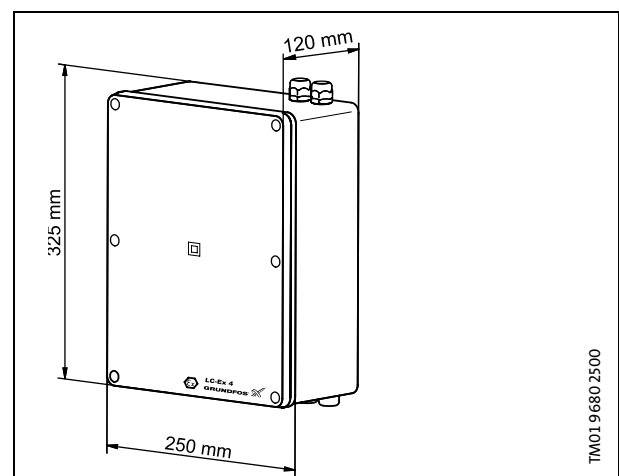

## Accessories for AP, KP stainless steel pumps

Pos.	Accessories		Pump type						Product number	
	Description		KP	AP 12.40	AP 12.50	AP 35	AP 35B	AP 50		AP 50B
1	Bushing for pipe connection (PVC)	Rp 1½/2		●		●				96 02 38 31
		Rp 2/2½			●			●		96 02 38 32
2	Hose nipple (PVC)	Rp 1¼/1¼		●		●				96 00 39 97
		Rp 1¼/2		●		●				96 02 38 34
		Rp 2/2			●		●	●	●	96 02 38 35
		Rp 2/2½			●			●	●	96 02 38 36
3	10 m rubber hose incl. clamps (PVC)	1½"		●		●				96 02 38 37
		2"		●	●	●	●	●	●	96 02 38 38
		2½"			●			●	●	96 02 38 39
4	Connecting piece for rubber hoses (PVC)	Rp 1½		●		●				96 02 38 40
		Rp 2		●	●	●	●	●	●	96 02 38 41
		Rp 2½			●			●	●	96 02 38 42
5	Non-return valve Ball type (PVC)	Rp 1½		●		●				96 02 38 43
		Rp 2		●	●	●	●	●	●	96 02 38 44
		Rp 2½ ★			●			●	●	96 00 20 03
6	Isolating valve (PVC)	Rp 1½		●		●				96 02 38 46
		Rp 2		●	●	●	●	●	●	96 02 38 47
		Rp 2½			●			●	●	96 02 38 48
7	Hexagon nipple (PVC)	Rp 1½		●		●				96 02 38 49
		Rp 2		●	●	●	●	●	●	96 02 38 50
		Rp 2½			●			●	●	96 02 38 51
8	Union (PVC)	Rp 1½		●		●				96 02 38 52
		Rp 2		●	●	●	●	●	●	96 02 38 53
		Rp 2½			●			●	●	96 02 38 54
9	90° pipe bend (PVC)	Rp 1½		●		●				96 02 38 55
		Rp 2		●	●	●	●	●	●	96 02 38 56
		Rp 2½			●			●	●	96 02 38 57
10	Non-return valve for location in the pump discharge (stainless steel)	Rp 1½	●							00 01 52 11
		Rp 1¼		●		●				96 00 38 55
	Auto-coupling	Rp 2/Rp 2					●		●	96 42 95 19
	Hose couplings Screwed couplings (polyamide)	G 1¼ x ø25	●							00 ID 35 88
G 1¼ x ø32		●							00 ID 35 89	
G 1¼ x ø40		●							00 ID 35 90	

★ Cast iron

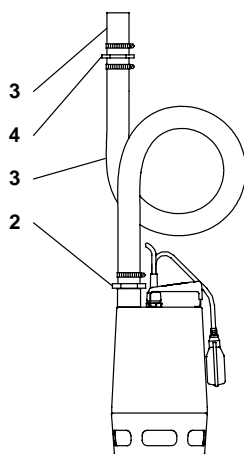

TM00 5924 1895

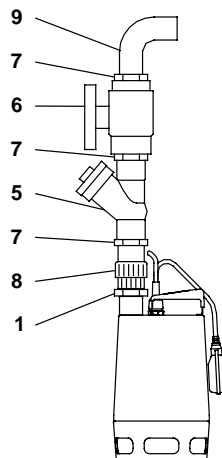

TM00 5925 1895

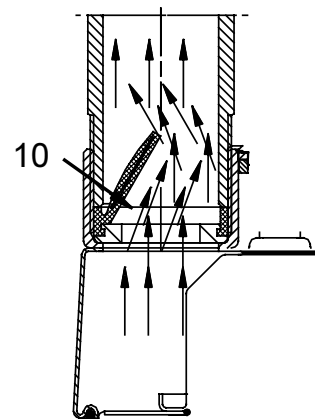

TM01 8708 0700



## Accessories for cast iron AP pumps

Pos.	Accessories Description		Pump type							Product number	
			AP 10.50	AP 10.65	AP 30	AP 51	AP65 Vortex	AP 70	AP80 Vortex		AP 100
10	90° elbow	R/Rp 2	●		●						96 00 19 80
		R/Rp 2½		●		●	●				96 00 19 81
11	Coupling half Storz coupling	Rp 2 for 2" hose (pos.13)	●		●						96 00 19 82
		Rp 2½ for 2" hose (pos.13)		●		●	●				96 00 19 83
		Rp 3 for 3" hose (pos.13)						●			96 00 19 84
12	Ring stand Ex. 90° elbow	R 3/DN 80 with elbow						●	●		96 00 01 84
		DN 100/DN 100 - 4" hose					●		●	●	96 00 34 24
		DN 150/DN 100 - 4" hose					●			●	96 00 38 35
		DN 150/DN 150 with elbow								●	96 00 34 25
		DN 150								●	96 00 40 29
		DN 200								●	96 00 40 30
		3"						●			
14	90° elbow	Rp/Rp 2	●		●						96 00 19 90
		Rp/Rp 2½		●		●	●				96 00 19 91
		Rp/Rp 3						●			96 00 19 92
15	90° elbow with flanges	DN 65, PN 10		●							96 00 36 16
		DN 80, PN 10						●	●		96 00 36 17
		DN 100, PN 10					●		●	●	96 00 36 18
		DN 150, PN 10								●	96 00 37 15
		DN 200, PN 10								●	96 00 38 36
16	Hexagon nipple	R/R 2	●		●						96 00 19 93
		R/R 2½		●		●	●				96 00 19 94
		R/R 3						●			96 00 19 95
17	Threaded flange	Rp 2½		●		●	●				96 00 19 96
		Rp 3						●			96 00 19 97
		Rp 4					●	●		●	96 00 33 36
18	Bolts, nuts and gaskets	4 of each M16 x 65 mm DN 65		●		●	●				96 00 19 98
		8 of each M16 x 65 mm DN 80						●	●		96 00 19 99
		8 of each M16 x 65 mm DN 100					●	●	●	●	96 00 38 23
		8 of each M20 x 75 mm DN 150								●	96 00 36 05
		8 of each M20 x 80 mm DN 200								●	96 00 38 37
19	Gasket	DN 65		●		●	●				96 00 20 00
		DN 80						●	●		96 00 20 01
		DN 100					●	●	●	●	96 00 33 31
		DN 150								●	96 00 36 06
		DN 200								●	96 00 38 38
20	Discharge pipe with 2 flanges, bolts, nuts and gaskets Length = 1 m	DN 65, PN 10		●		●	●				96 00 36 10
		DN 80, PN 10						●	●		96 00 36 11
		DN 100, PN 10					●		●	●	96 00 36 12
		DN 150, PN 10							●	●	96 00 38 41
		DN 200, PN 10								●	96 00 44 15
20a	Discharge pipe extension (1 m)	DN 65, PN 10		●		●	●				96 00 36 13
		DN 80, PN 10						●	●		96 00 36 14
		DN 100, PN 10					●	●	●	●	96 00 36 15
		DN 150, PN 10							●	●	96 00 37 11
		DN 200, PN 10								●	96 00 44 18
21	Non-return valve Cast iron ball-type valve	Rp/Rp 2	●		●						96 00 20 02
		Rp/Rp 2½		●		●	●				96 00 20 03
		Rp/Rp 3						●			96 00 20 04
22	Isolating valve Brass	Rp/Rp 2	●		●						96 00 20 05
		Rp/Rp 2½		●		●	●				96 00 20 06
		Rp/Rp 3						●			96 00 20 07

Pos.	Accessories		Pump type							Product number	
			AP 10.50	AP 10.65	AP 30	AP 51	AP65 Vortex	AP 70	AP80 Vortex		AP 100
23	Non-return valve Cast iron ball-type valve	DN 65		●		●	●				96 00 20 08
		DN 80						●	●		96 00 20 09
		DN 100					●	●	●	●	96 00 20 85
		DN 150							●	●	96 00 34 23
		DN 200								●	96 00 38 39
24	Isolating valve Cast iron	DN 65		●		●	●				96 00 20 10
		DN 80						●	●		96 00 20 11
		DN 100					●	●	●	●	96 00 20 12
		DN 150					●		●	●	96 00 34 27
		DN 200								●	96 00 38 40
25	Auto-coupling system complete	Rp 2/Rp 2	●		●						96 00 01 78
		Rp 2/Rp 2, hook-up	●		●						96 00 44 42
		DN 65/Rp 2½		●		●	●				96 00 01 80
		DN 80/DN 80						●	●		96 00 66 56
		DN 100/DN 80						●	●		96 00 66 57
		DN 100/DN 100					●		●	●	96 00 66 58
		DN 150/DN 100					●		●	●	96 00 66 59
		DN 150/DN 150 (pumps up to 17 kW)								●	96 00 66 64
		DN 150/DN 150 (pumps from 22 kW)								●	96 00 40 18
		DN 200/DN 150 (pumps from 22 kW)								●	96 00 40 19
		DN 200/DN 200								●	96 00 40 20
								●	96 00 40 21		
26	Chain with shackle - galvanized (AP100 up to and including 17 kW)	10 m	●	●	●	●	●	●	●	●	96 00 20 13
		6 m	●	●			●	●	●	●	96 00 36 33
		3 m	●	●			●	●	●	●	96 00 36 34
		Chain with shackle - stainless steel (AP100 as from 22 kW)	6 m						●	●	96 00 44 25
27	Collecting steel pipes for two pumps and 90° outlet, centre discharge Flanges are welded. Pipes are painted.	3 x DN 65		●		●	●				96 00 36 19
		DN 65/65/80		●		●	●				96 00 36 20
		3 x DN 80						●	●		96 00 36 21
		DN 80/80/100						●	●		96 00 36 22
		3 x DN 100					●		●	●	96 00 36 23
28	Basestand Dry pit stand for vertical installation incl. 90° suction elbow	DN100/DN100					●		●	●	96 00 36 25
		DN 150/DN 150 (up to and including 17 kW)								●	96 00 38 32
		DN 150/DN 150 (as from 22 kW)								●	96 00 41 93
		DN 200/DN 150 (up to and including 17 kW)								●	96 00 40 24
		DN 200/DN 150 (as from 22 kW)								●	96 00 41 94
		DN 200/DN 200								●	96 00 40 25
		DN 250/DN 200								●	96 00 40 26
29	Cable protection	5 m x 1"	●	●	●	●	●	●	●	●	96 00 20 84

Pos.	Accessories		Pump type							Product number			
			AP 10.50	AP 10.65	AP 30	AP 51	AP65 Vortex	AP 70	AP80 Vortex		AP 100		
30	Float switch without mercury 1 switch with 10 m cable		•	•	•	•	•	•	•	•	96 00 33 32		
	Float switch with 20 m cable		•	•	•	•	•	•	•	•	96 00 36 95		
	Float switch for explosion protection with 10 m cable		•	•	•	•	•	•	•	•	96 00 34 21		
	Float switch for explosion protection with 20 m cable		•	•	•	•	•	•	•	•	96 00 35 36		
	Bracket for level switch		•	•	•	•	•	•	•	•	96 00 33 38		
	Standard float switch without mercury With 10 m cable, counter weight and bracket		1 pump without alarm (2 switches)		•	•	•	•	•	•	•	62 50 00 13	
			1 pump with alarm (3 switches)		•	•	•	•	•	•	•	62 50 00 14	
			2 pumps without alarm (3 switches)		•	•	•	•	•	•	•	62 50 00 14	
			2 pumps with alarm (4 switches)		•	•	•	•	•	•	•	62 50 00 15	
	Float switches for explosion protection With 10 m cable, counter weight and bracket		1 pump without alarm (2 switches)	•	•	•	•	•	•	•	•	62 50 00 16	
			1 pump with alarm (3 switches)	•	•	•	•	•	•	•	•	•	62 50 00 17
			2 pumps without alarm (3 switches)	•	•	•	•	•	•		•	•	62 50 00 17
			2 pumps with alarm (4 switches)	•	•	•	•	•	•	•	•	•	62 50 00 18
	31	Signal lamp 1 x 230 V	Outdoor mounting	•	•	•	•	•	•	•	•	62 50 00 20	
	32	Acoustic signal (horn) 1 x 230V	Outdoor mounting	•	•	•	•	•	•	•	•	62 50 00 21	
Indoor mounting			•	•	•	•	•	•	•	•	62 50 00 22		
33	Discharge pipe with 90° bend and two flanges. For 1 pump.	DN 65, L = 1300 mm		•		•	•				96 00 38 42		
		DN 80, L = 1300 mm						•	•		96 00 38 43		
		DN 100, L = 1300 mm							•	•	96 00 38 44		
		DN 150, L = 1300 mm							•	•	96 00 38 45		
		DN 150, L = 1600 mm								•	•	96 00 39 79	
34	Collecting steel pipes for two pumps. Sideways discharge	DN 65, L = 1920 mm		•		•	•				96 00 38 46		
		DN 80, L = 1920 mm						•	•		96 00 38 47		
		DN 100, L = 1920 mm					•		•	•	96 00 38 48		
		DN 150, L = 1920 mm							•	•	96 00 38 49		
		DN 150, L = 2220 mm								•	•	96 00 39 80	

## Level controllers and accessories

	Description	Operating current per pump [A]	Mains switch required [A]	Grundfos Product no. *	Grundfos product no. including hour counter*	Grundfos product no. including start counter*	Grundfos product no. including combined hour and start counter*	
	TM01 8874 0800 LC 107 level controller for 1 pump 1 x 230 V, direct-on-line starting	1 - 2.9	25	96 00 24 64				
		1.6 - 5.0	25	96 00 24 65				
		3.7 - 12.0	25	96 00 24 66				
	LC 107 level controller for 1 pump 3 x 400 V, direct-on-line starting	1 - 2.9	25	96 00 24 67				
		1.6 - 5.0	25	96 00 24 68				
		3.7 - 12.0	25	96 00 24 69				
	TM01 8875 0800 LCD 107 level controller for 2 pumps 1 x 230 V, direct-on-line starting	1 - 2.9	25	96 00 24 71				
		1.6 - 5.0	25	96 00 24 72				
		3.7 - 12.0	25	96 00 24 73				
	LCD 107 level controller for 2 pumps 3 x 400 V, direct-on-line starting	1 - 2.9	25	96 00 24 74				
		1.6 - 5.0	25	96 00 24 75				
		3.7 - 12.0	25	96 00 24 76				
	TM01 8873 0800 LC 108 level controller for 1 pump 1 x 230 V, direct-on-line starting	1 - 2.9	25	96 43 39 56	96 43 39 57	96 43 39 58	96 43 39 59	
		1.6 - 5.0	25	96 43 39 61	96 43 39 60	96 43 39 62	96 43 39 63	
		3.7 - 12.0	25	96 43 39 64	96 43 39 65	96 43 39 66	96 43 39 67	
		12.0 - 23.0	40	96 43 39 71	96 43 39 72	96 43 39 73	96 43 39 74	
		1 - 2.9	25	96 43 39 75	96 43 39 76	96 43 39 77	96 43 39 78	
		1.6 - 5.0	25	96 43 39 79	96 43 39 80	96 43 39 81	96 43 39 82	
	LC 108 level controller for 1 pump 3 x 230 V, direct-on-line starting	3.7 - 12.0	25	96 43 39 83	96 43 39 84	96 43 39 85	96 43 39 86	
		12.0 - 23.0	40	96 43 39 87	96 43 39 88	96 43 39 89	96 43 39 90	
		1 - 2.9	25	96 43 39 91	96 43 39 92	96 43 39 93	96 43 39 94	
		1.6 - 5.0	25	96 43 39 95	96 43 39 96	96 43 39 97	96 43 39 98	
		3.7 - 12.0	25	96 43 39 99	96 43 40 00	96 43 40 01	96 43 40 02	
		12.0 - 23.0	40	96 43 40 03	96 43 40 04	96 43 40 05	96 43 40 06	
	LC 108 level controller for 1 pump 3 x 400 V, star-delta starting	6.4 - 20.0	25	96 43 79 28				
		20.8 - 30.0	40	96 43 79 50				
		20.8 - 59.0	80	96 43 79 70				
		24.2 - 72.0		96 43 79 90				
		TM01 8876 0800 LCD 108 level controller for 2 pumps 3 x 230 V, direct-on-line starting	1 - 2.9	25	96 43 40 23	96 43 40 24	96 43 40 25	96 43 40 26
			1.6 - 5.0	25	96 43 40 27	96 43 40 28	96 43 40 29	96 43 40 30
3.7 - 12.0	25		96 43 40 31	96 43 40 32	96 43 40 33	96 43 40 34		
12.0 - 23.0	40		96 43 40 35	96 43 40 36	96 43 40 37	96 43 40 38		
1 - 2.9	25		96 43 40 39	96 43 40 40	96 43 40 41	96 43 40 42		
1.6 - 5.0	25		96 43 40 43	96 43 40 44	96 43 40 45	96 43 40 46		
LCD 108 level controller for 2 pumps 3 x 400 V, direct-on-line starting	3.7 - 12.0	40	96 43 40 47	96 43 40 48	96 43 40 49	96 43 40 50		
	12.0 - 23.0	60	96 43 40 51	96 43 40 52	96 43 40 53	96 43 40 54		
	6.4 - 20.0	25	96 43 80 32					
	20.8 - 30.0	40	96 43 80 52					
	20.8 - 59.0	80	96 43 80 72					
	24.2 - 72.0		96 43 80 92					

\*Includes Instruction and operating manual in English. Other languages are available on request.

## Accessories for controllers

Description	Grundfos product no.
Battery back-up	96 00 25 20
Flashing beacon for external alarm indication	62 50 00 20
Alarm horn for external alarm indication (outdoor installation)	62 50 00 21
Alarm horn for external alarm indication (indoor installation)	62 50 00 22
Hour counter [230 V]	96 00 25 14
Hour counter [400 V]	96 00 25 15
Start counter [230 V]	96 00 25 16
Start counter [400 V]	96 00 25 17
Combined hour and start counter [230 V]	96 00 25 18
Combined hour and start counter [400 V]	96 00 25 19
25 [A] external mains switch for supply cable	96 00 25 11
40 [A] external mains switch for supply cable	96 00 25 12
80 [A] external mains switch for supply cable	96 00 25 13
LC-Ex4	96 44 03 00

## Free-standing installation or portable

AP10  
 AP30  
 AP51  
 AP65 Vortex  
 AP70  
 AP80 Vortex  
 AP100

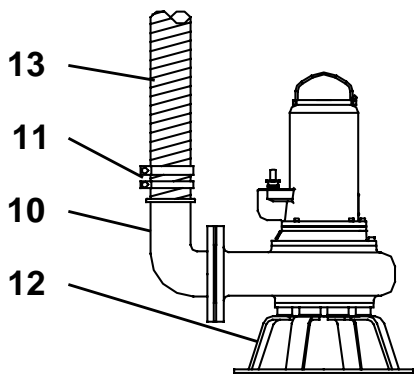

TM01.2542.2098

## Vertical dry installation (D)

AP80 Vortex  
 AP100

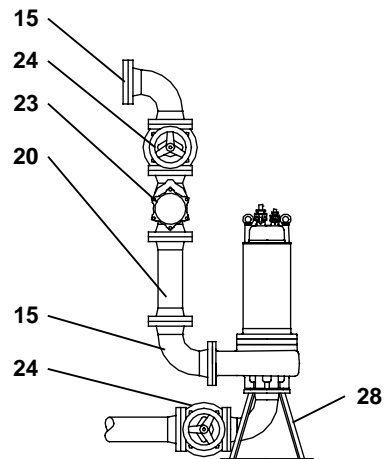

TM01.0749.1398

## Installation on auto-coupling

AP10  
 AP30  
 AP51  
 AP65 Vortex  
 AP70

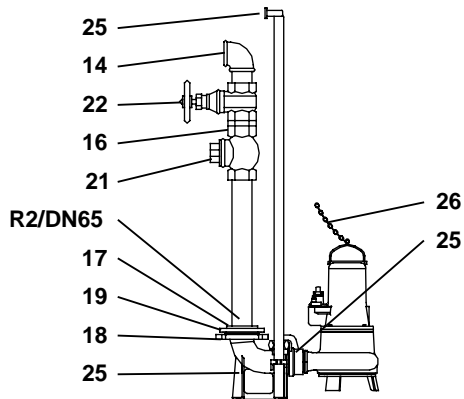

TM01.2543.2098

## Installation on auto-coupling

AP70  
 AP80 Vortex  
 AP100

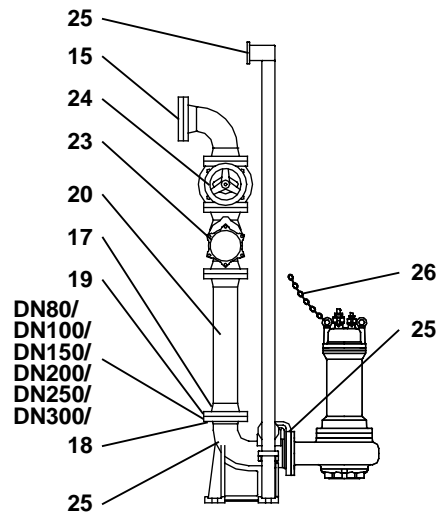

TM00.5616.1398

## Accessories

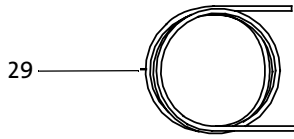

TM00 3618 0794

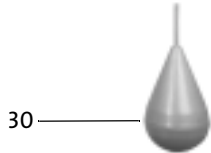

TM01 6982 3999



TM01 7286 4299

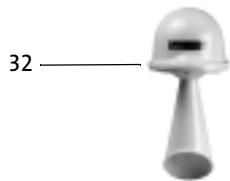

TM01 7187 4099

## Pipe dimensions

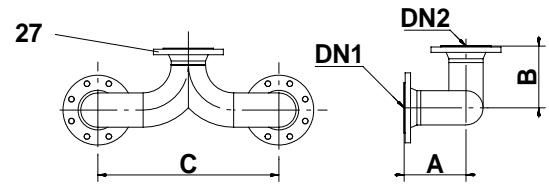

TM01 0753 2197

Dimensions	DN 1	DN 2	A	B	C	Prod. no.
3 x DN 65, PN 10	65	65	140	140	380	96 00 36 19
DN 65/ 65/ 80, PN 10	65	80	140	235	380	96 00 36 20
3 x DN 100, PN 10	100	100	205	205	611	96 00 36 23

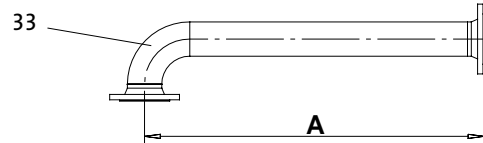

TM01 0898 1498

Dimensions	A	Prod. no.
2 x DN 65, PN 10	1300	96 00 38 42
2 x DN 100, PN 10	1300	96 00 38 44
2 x DN 150, PN 10 for 1.5 m pit	1300	96 00 38 45
2 x DN 150, PN 10 for 2.0 m pit	1300	96 00 38 79

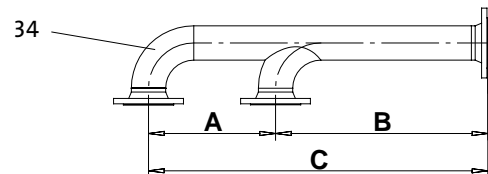

TM01 0899 3797

Dimensions	A	B	C	Prod. no.
3 x DN 65, PN 10	620	1300	1920	96 00 38 46
3 x DN 100, PN 10	620	1300	1920	96 00 38 48
3 x DN 150, PN 10 for 2.0 m pit	620	1300	1920	96 00 38 49
3 x DN 150, PN 10 for 2.5 m pit	620	1600	2220	96 00 39 80



## KP 150

### 1 x 220 - 230 V

Pump type	Float switch	Vertical level switch	3 m cable	10 m cable	With plug	Plug type	Product no.
KP 150					●	Schuko	01 1H 13 00
KP 150	●		●		●	Schuko	01 1H 16 00
KP 150		●	●		●	Schuko	01 1H 14 00
KP 150	●			●	●	Schuko	01 1H 18 00
KP 150		●		●	●	Schuko	01 1H 19 00
KP 150				●	●	Denmark	01 1H 23 00
KP 150	●		●		●	Denmark	01 1H 26 00
KP 150		●	●		●	Denmark	01 1H 24 00
KP 150	●			●	●	Denmark	01 1H 28 00
KP 150		●		●	●	Denmark	01 1H 29 00
KP 150				●	●	Switzerland	01 1H 33 00
KP 150	●		●		●	Switzerland	01 1H 36 00
KP 150		●	●		●	Switzerland	01 1H 34 00
KP 150	●			●	●	Switzerland	01 1H 38 00
KP 150		●		●	●	Switzerland	01 1H 39 00
KP 150				●	●	Italy	01 1H 53 00
KP 150	●		●		●	Italy	01 1H 56 00
KP 150		●	●		●	Italy	01 1H 54 00
KP 150				●	●	Italy	01 1H 58 00
KP 150				●			01 1H 63 00
KP 150	●		●				01 1H 66 00
KP 150		●	●				01 1H 64 00
KP 150	●						01 1H 68 00
KP 150		●		●			01 1H 69 00

### 1 x 230 - 240 V

Pump type	Float switch	Vertical level switch	5 m cable	With plug	Plug type	Product no.
KP 150			●	●	Australia	01 1K 41 00
KP 150	●		●	●	Australia	01 1K 47 00
KP 150		●	●	●	Australia	01 1K 45 00

## KP 250

### 1 x 220 - 230 V

Pump type	Float switch	Vertical level switch	3 m cable	10 m cable	With plug	Plug type	Product no.
KP 250				●	●	Schuko	01 2H 13 00
KP 250	●		●		●	Schuko	01 2H 16 00
KP 250		●	●		●	Schuko	01 2H 14 00
KP 250	●			●	●	Schuko	01 2H 18 00
KP 250		●		●	●	Schuko	01 2H 19 00
KP 250				●	●	Denmark	01 2H 23 00
KP 250	●		●		●	Denmark	01 2H 26 00
KP 250		●	●		●	Denmark	01 2H 24 00
KP 250	●			●	●	Denmark	01 2H 28 00
KP 250		●		●	●	Denmark	01 2H 29 00
KP 250				●	●	Switzerland	01 2H 33 00
KP 250	●		●		●	Switzerland	01 2H 36 00
KP 250		●	●		●	Switzerland	01 2H 34 00
KP 250	●			●	●	Switzerland	01 2H 38 00
KP 250		●		●	●	Switzerland	01 2H 39 00
KP 250				●	●	Italy	01 2H 53 00
KP 250	●		●		●	Italy	01 2H 56 00
KP 250		●	●		●	Italy	01 2H 54 00
KP 250	●			●	●	Italy	01 2H 58 00
KP 250				●			01 2H 63 00
KP 250	●		●				01 2H 66 00
KP 250		●	●				01 2H 64 00
KP 250	●			●			01 2H 68 00
KP 250		●					01 2H 69 00

### 1 x 230 - 240 V

Pump type	Float switch	Vertical level switch	5 m cable	With plug	Plug type	Product no.
KP 250			●	●	Australia	01 2K 41 00
KP 250	●		●	●	Australia	01 2K 47 00
KP 250		●	●	●	Australia	01 2K 45 00

### 3 x 380 - 415 V

Pump type	5 m cable	10 m cable	Product no.
KP 250	●		01 2M 61 00
KP 250		●	01 2M 63 00
KP 250	●		01 2M 91 00
KP 250		●	01 2M 93 00

## KP 350

### 1 x 220 - 240 V

Pump type	Float switch	Vertical level switch	3 m cable	5 m cable	10 m cable	With plug	Plug type	Product no.
KP 350					•	•	Schuko	01 3N 13 00
KP 350	•		•			•	Schuko	01 3N 16 00
KP 350		•	•			•	Schuko	01 3N 14 00
KP 350	•				•	•	Schuko	01 3N 18 00
KP 350		•			•	•	Schuko	01 3N 19 00
KP 350					•	•	Denmark	01 3N 23 00
KP 350	•		•			•	Denmark	01 3N 26 00
KP 350		•	•			•	Denmark	01 3N 24 00
KP 350	•				•	•	Denmark	01 3N 28 00
KP 350		•			•	•	Denmark	01 3N 29 00
KP 350					•	•	Switzerland	01 3N 33 00
KP 350		•	•			•	Switzerland	01 3N 34 00
KP 350	•		•			•	Switzerland	01 3N 36 00
KP 350	•				•	•	Switzerland	01 3N 38 00
KP 350		•			•	•	Switzerland	01 3N 39 00
KP 350					•			01 3N 63 00
KP 350	•		•					01 3N 66 00
KP 350		•	•					01 3N 64 00
KP 350	•				•			01 3N 68 00
KP 350					•			01 3N 69 00
KP 350				•		•	Australia	01 3N 41 00
KP 350	•			•		•	Australia	01 3N 47 00
KP 350		•		•		•	Australia	01 3N 45 00

### 3 x 380 - 415 V

Pump type	5 m cable	10 m cable	Product no.
KP 350	•		01 3M 61 00
KP 350		•	01 3M 63 00
KP 350	•		01 3M 91 00
KP 350		•	01 3M 93 00

## AP10

Pump type	Voltage	Control box with 0.8 m supply cable	Float switch	10 m cable	With plug	Product no.
AP10.65.21.3	3 x 400 V	●		●		96 00 25 32
AP10.65.21.3	3 x 230 V	●		●		96 00 25 39
AP10.65.21.3	3 x 400 V	●		●	●	96 00 25 34
AP10.65.21.A.3	3 x 400 V	●	●	●		96 00 25 33
AP10.65.21.A.3	3 x 230 V	●	●	●		96 00 25 40
AP10.65.21.A.3	3 x 400 V	●	●	●	●	96 00 25 35

## AP12

Pump type	Voltage	Control box with 0.8 m supply cable	Float switch	10 m cable	3 m cable	With plug	Product no.
AP12.40.04.1	1 x 230 V			●		●	96 01 10 16
AP12.40.04.1	1 x 230 V			●			96 01 10 14
AP12.40.04.A.1	1 x 230 V		●		●	●	96 01 10 17
AP12.40.04.A.1	1 x 230 V		●		●		96 01 10 15
AP12.40.04.A.1	1 x 230 V		●			●	96 01 10 18
AP12.40.04.3	3 x 400 V			●			96 01 10 24
AP12.40.04.3	3 x 400 V			●		●	96 02 39 25
AP12.40.04.3	3 x 230 V			●			96 01 10 30
AP12.40.04.3	3 x 200 V			●			96 01 10 21
AP12.40.04.A.3	3 x 400 V	●	●	●			96 01 10 25
AP12.40.04.A.3	3 x 400 V	●	●	●		●	96 02 38 71
AP12.40.04.A.3	3 x 230 V	●	●	●			96 01 10 31
AP12.40.04.A.3	3 x 200 V	●	●	●			96 01 10 39
AP12.40.06.1	1 x 230 V			●		●	96 00 17 20
AP12.40.06.1	1 x 230 V			●			96 00 17 32
AP12.40.06.A.1	1 x 230 V		●		●	●	96 00 17 35
AP12.40.06.A.1	1 x 230 V		●	●		●	96 01 09 79
AP12.40.06.A.1	1 x 230 V		●		●		96 00 17 47
AP12.40.06.3	3 x 400 V			●			96 00 16 52
AP12.40.06.3	3 x 230 V			●			96 01 06 28
AP12.40.06.3	3 x 200 V			●			96 01 08 81
AP12.40.06.A.3	3 x 400 V	●	●	●			96 01 09 23
AP12.40.06.A.3	3 x 400 V	●	●	●		●	96 02 38 72
AP12.40.06.A.3	3 x 230 V	●	●	●			96 01 09 57
AP12.40.06.A.3	3 x 200 V	●	●	●			96 01 09 22
AP12.40.08.1	1 x 230 V			●			96 00 18 73
AP12.40.08.1	1 x 230 V			●		●	96 00 18 69
AP12.40.08.A.1	1 x 230 V		●		●	●	96 00 17 98
AP12.40.08.A.1	1 x 230 V		●	●		●	96 01 09 80
AP12.04.08.A.1	1 x 230 V		●		●		96 00 18 67
AP12.40.08.3	3 x 400 V			●			96 00 17 91
AP12.40.08.3	3 x 230 V			●			96 01 06 30
AP12.40.08.3	3 x 200 V			●			96 01 08 82
AP12.40.08.A.3	3 x 400 V	●	●	●			96 01 09 25
AP12.40.08.A.3	3 x 400 V	●	●	●		●	96 02 38 73
AP12.40.08.A.3	3 x 230 V	●	●	●			96 01 09 58
AP12.40.08.A.3	3 x 200 V	●	●	●			96 01 09 24
AP12.50.11.1	1 x 230 V			●		●	96 00 19 58
AP12.50.11.1	1 x 230 V			●			96 00 19 62
AP12.50.11.A.1	1 x 230 V		●		●	●	96 00 19 65
AP12.50.11.A.1	1 x 230 V		●		●		96 00 19 73
AP12.50.11.A.1	1 x 230 V		●	●		●	96 01 09 81
AP12.50.11.3	3 x 400 V			●			96 00 19 75
AP12.50.11.3	3 x 230 V			●			96 01 06 34
AP12.50.11.3	3 x 200 V			●			96 01 08 83
AP12.50.11.A.3	3 x 400 V	●	●	●			96 01 09 27
AP12.50.11.A.3	3 x 400 V	●	●	●		●	96 02 38 74
AP12.50.11.A.3	3 x 230 V	●	●	●			96 01 09 59
AP12.50.11.A.3	3 x 200 V	●	●	●			96 01 09 26

## AP30

Pump type	Voltage	Control box with 0.8 m supply cable	Float switch	10 m cable	With plug	Product no.
AP30.50.07.1	1 x 230 V	●		●	●	96 00 25 49
AP30.50.07.1	1 x 230 V			●		96 00 25 41
AP30.50.07.A.1	1 x 230 V	●	●	●	●	96 00 25 50
AP30.50.07.A.1	1 x 230 V	●	●	●		96 00 25 42
AP30.50.09.3	3 x 400 V			●		96 00 25 57
AP30.50.09.3	3 x 230 V			●		96 00 25 76
AP30.50.09.A.3	3 x 400 V	●	●	●		96 00 25 58
AP30.50.09.A.3	3 x 230 V	●	●	●		96 00 25 77
AP30.50.09.A.3	3 x 400 V	●	●	●	●	96 00 25 72
AP30.50.11.1	1 x 230 V	●		●	●	96 00 25 51
AP30.50.11.1	1 x 230 V			●		96 00 25 43
AP30.50.11.A.1	1 x 230 V	●	●	●	●	96 00 25 52
AP30.50.11.A.1	1 x 230 V	●	●	●		96 00 25 44
AP30.50.12.3	3 x 400 V			●		96 00 25 60
AP30.50.12.3	3 x 230 V			●		96 00 25 79
AP30.50.12.A.3	3 x 400 V	●	●	●		96 00 25 61
AP30.50.12.A.3	3 x 230 V	●	●	●		96 00 25 80
AP30.50.12.A.3	3 x 400 V	●	●	●	●	96 00 25 73

## AP35

Pump type	Voltage	Control box with 0.8 m supply cable	Float switch	10 m cable	3 m cable	With plug	Product no.
AP35.40.06.1.V	1 x 230 V			●		●	96 00 17 96
AP35.40.06.1.V	1 x 230 V			●			96 00 18 08
AP35.40.06.A.1.V	1 x 230 V		●		●	●	96 00 17 77
AP35.40.06.A.1.V	1 x 230 V		●		●		96 00 17 89
AP35.40.06.A.1.V	1 x 230 V		●	●		●	96 01 09 82
AP35.40.06.3.V	3 x 400 V			●			96 00 01 69
AP35.40.06.3.V	3 x 230 V			●			96 01 06 29
AP35.40.06.3.V	3 x 200 V						96 01 08 84
AP35.40.06.A.3.V	3 x 400 V	●	●	●			96 01 09 29
AP35.40.06.A.3.V	3 x 400 V	●	●	●		●	96 02 38 75
AP35.40.06.A.3.V	3 x 230 V	●	●	●			96 01 09 60
AP35.40.06.A.3.V	3 x 200 V	●	●	●			96 01 09 28
AP35.40.08.1.V	1 x 230 V			●		●	96 00 16 72
AP35.40.08.1.V	1 x 230 V			●			96 00 18 94
AP35.40.08.A.1.V	1 x 230 V		●		●	●	96 00 18 97
AP35.40.08.A.1.V	1 x 230 V		●		●		96 00 19 05
AP35.40.08.A.1.V	1 x 230 V		●	●		●	96 01 09 83
AP35.40.08.3.V	3 x 400 V			●			96 00 17 18
AP35.40.08.3.V	3 x 230 V			●			96 01 06 31
AP35.40.08.3.V	3 x 200 V			●			96 01 08 85
AP35.40.08.A.3.V	3 x 400 V	●	●	●			96 01 09 31
AP35.40.08.A.3.V	3 x 400 V	●	●	●		●	96 02 38 76
AP35.40.08.A.3.V	3 x 230 V	●	●	●			96 01 09 61
AP35.40.08.A.3.V	3 x 200 V	●	●	●			96 01 09 30

## AP35B

Pump type	Voltage	Float switch	10 m cable	5 m cable	With plug	Product no.
AP35B.50.06.A1.V	1 x 230 V	●		●	●	96 00 45 62
AP35B.50.06.1.V	1 x 230 V		●		●	96 00 45 63
AP35B.50.06.3.V	3 x 400 V			●		96 00 45 65
AP35B.50.08.A1.V	1 x 230 V	●		●	●	96 00 45 74
AP35B.50.08.1.V	1 x 230 V		●		●	96 00 45 75
AP35B.50.08.3.V	3 x 400 V			●		96 00 45 77

## AP50

Pump type	Voltage	Control box with 0.8 m supply cable	Float switch	10 m cable	3 m cable	With plug	Product no.
AP50.50.08.1.V	1 x 230 V			●		●	96 01 05 95
AP50.50.08.1.V	1 x 230 V			●			96 01 05 99
AP50.50.08.A.1.V	1 x 230 V		●		●	●	96 01 05 84
AP50.50.08.A.1.V	1 x 230 V		●	●		●	96 01 09 84
AP50.50.08.A.1.V	1 x 230 V		●		●		96 01 05 92
AP50.50.08.3.V	3 x 400 V			●			96 01 05 63
AP50.50.08.3.V	3 x 230 V			●			96 01 06 32
AP50.50.08.3.V	3 x 200 V			●			96 01 08 86
AP50.50.08.A.3.V	3 x 400 V	●	●	●			96 01 09 33
AP50.50.08.A.3.V	3 x 400 V	●	●	●		●	96 02 38 77
AP50.50.08.A.3.V	3 x 230 V	●	●	●			96 01 09 62
AP50.50.08.A.3.V	3 x 200 V	●	●	●			96 01 09 32
AP50.50.11.1.V	1 x 230 V			●		●	96 01 05 77
AP50.50.11.1.V	1 x 230 V			●			96 01 05 81
AP50.50.11.A.1.V	1 x 230 V		●		●	●	96 01 05 66
AP50.50.11.A.1.V	1 x 230 V		●	●		●	96 01 09 85
AP50.50.11.A.1.V	1 x 230 V		●		●		96 01 05 74
AP50.50.11.3.V	3 x 400 V			●			96 01 05 62
AP50.50.11.3.V	3 x 230 V			●			96 01 06 33
AP50.50.11.3.V	3 x 200 V			●			96 01 08 87
AP50.50.11.A.3.V	3 x 400 V	●	●	●			96 01 09 35
AP50.50.11.A.3.V	3 x 400 V	●	●	●		●	96 02 38 78
AP50.50.11.A.3.V	3 x 230 V	●	●	●			96 01 09 63
AP50.50.11.A.3.V	3 x 200 V	●	●	●			96 01 09 34

## AP50B

Pump type	Voltage	Control box with 0.8 m supply cable	Float switch	10 m cable	5 m cable	With plug	Product no.
AP50B.50.08.A1.V	1 x 230 V		●		●	●	96 00 45 86
AP50B.50.08.1.V	1 x 230 V			●		●	96 00 45 87
AP50B.50.08.3.V	3 x 400 V				●		96 00 45 89
AP50B.50.11.A1.V	1 x 230 V		●		●	●	96 00 45 98
AP50B.50.11.1.V	1 x 230 V			●		●	96 00 45 99
AP50B.50.11.3.V	3 x 400 V				●		96 00 46 01
AP50B.50.15.3.V	3 x 400 V				●		96 00 46 09

## AP51

Pump type	Voltage	Control box with 0.8 m supply cable	Float switch	With temperature sensors in the motor windings	10 m cable	With plug	Product no.
AP51.65.07.1	1 x 230 V	●			●	●	96 00 25 53
AP51.65.07.1	1 x 230 V				●		96 00 25 45
AP51.65.07.A.1	1 x 230 V	●	●		●	●	96 00 25 54
AP51.65.07.A.1	1 x 230 V	●	●		●		96 00 25 46
AP51.65.07.3	3 x 400 V				●		96 00 25 63
AP51.65.07.3	3 x 230 V				●		96 00 25 82
AP51.65.07.A.3	3 x 400 V	●	●		●		96 00 25 64
AP51.65.07.A.3	3 x 230 V	●	●		●		96 00 25 83
AP51.65.07.A.3	3 x 400 V	●	●		●	●	96 00 25 74
AP51.65.12.1	1 x 230 V	●			●	●	96 00 25 55
AP51.65.12.1	1 x 230 V				●		96 00 25 47
AP51.65.12.A.1	1 x 230 V	●	●		●	●	96 00 25 56
AP51.65.12.A.1	1 x 230 V	●	●		●		96 00 25 48
AP51.65.12.3	3 x 400 V				●		96 00 25 65
AP51.65.12.3	3 x 230 V				●		96 00 25 84
AP51.65.12.A.3	3 x 400 V	●	●		●		96 00 25 66
AP51.65.12.A.3	3 x 230 V	●	●		●		96 00 25 85
AP51.65.12.A.3	3 x 400 V	●	●		●	●	96 00 25 75
AP51.65.17.3	3 x 400 V				●		96 00 25 67
AP51.65.17.3	3 x 400 V			●	●		96 00 25 68
AP51.65.17.3	3 x 230 V				●		96 00 25 86
AP51.65.22.3	3 x 400 V				●		96 00 25 69
AP51.65.22.3	3 x 400 V			●	●		96 00 25 70
AP51.65.22.3	3 x 230 V				●		96 00 25 87

## AP65 Vortex

Pump type	Voltage	Moisture sensors	Control box with 0.8 m supply cable	Float switch	10 m cable	Product no.
AP65.65.09.1.V	1 x 230 V				●	96 00 40 00
AP65.65.09.A.1.V	1 x 230 V		●	●	●	96 00 40 01
AP65.65.09.3.V	3 x 230 V				●	96 00 44 11
AP65.65.09.A.3.V	3 x 230 V		●	●	●	96 00 44 12
AP65.65.09.3.V	3 x 400 V				●	96 00 40 02
AP65.65.09.A.3.V	3 x 400 V		●	●	●	96 00 40 03
AP65.65.12.1.V	1 x 230 V				●	96 00 40 04
AP65.65.12.A.1.V	1 x 230 V		●	●	●	96 00 40 05
AP65.65.12.3.V	3 x 230 V				●	96 00 44 13
AP65.65.12.A.3.V	3 x 230 V		●	●	●	96 00 44 14
AP65.65.12.3.V	3 x 400 V				●	96 00 40 06
AP65.65.12.A.3.V	3 x 400 V		●	●	●	96 00 40 07
AP65.100.24.V	3 x 400 V				●	96 00 45 36
AP65.100.24.V	3 x 400 V	●			●	96 00 45 41
AP65.100.32.V	3 x 400 V				●	96 00 45 37
AP65.100.32.V	3 x 400 V	●			●	96 00 45 42
AP65.100.45.V	3 x 400 V				●	96 00 45 38
AP65.100.45.V	3 x 400 V	●			●	96 00 45 43
AP65.100.61.V	3 x 400 V				●	96 00 45 39
AP65.100.61.V	3 x 400 V	●			●	96 00 63 21
AP65.100.130.V	3 x 400 V				●	96 00 45 40
AP65.100.130.V	3 x 400 V	●			●	96 00 63 22

## AP70

Pump type	Voltage	With temperature sensors in the motor windings	10 m cable	Product no.
AP70.80.09.3	3 x 400 V		●	96 00 25 89
AP70.80.09.3	3 x 230 V		●	96 00 26 01
AP70.80.09.3	3 x 400 V	●	●	96 00 25 90
AP70.80.13.3	3 x 400 V		●	96 00 25 92
AP70.80.13.3	3 x 230 V		●	96 00 26 03
AP70.80.13.3	3 x 400 V	●	●	96 00 25 93
AP70.80.19.3	3 x 400 V		●	96 00 25 95
AP70.80.19.3	3 x 230 V		●	96 00 26 05
AP70.80.19.3	3 x 400 V	●	●	96 00 25 96
AP70.80.24.3	3 x 400 V		●	96 00 25 98
AP70.80.24.3	3 x 230 V		●	96 00 26 07
AP70.80.24.3	3 x 400 V	●	●	96 00 25 99



## AP80 Vortex standard version

Pump type	Voltage	Moisture sensor	Cooling jacket	Horizontal version	10 m cable	Product no.
AP80.80.10V	3 x 230 V				●	96 00 62 92
AP80.80.13V	3 x 230 V				●	96 00 62 93
AP80.80.20V	3 x 230 V				●	96 00 62 94
AP80.80.26V	3 x 230 V				●	96 00 62 95
AP80.80.10V	3 x 400 V				●	96 00 53 56
AP80.80.13V	3 x 400 V				●	96 00 53 57
AP80.80.20V	3 x 400 V				●	96 00 53 58
AP80.80.26V	3 x 400 V				●	96 00 53 59
AP80.80.48V	3 x 400 V				●	96 00 61 96
AP80.80.48V	3 x 400 V	●			●	96 00 62 02
AP80.80.48.V.D	3 x 400 V	●	●		●	96 00 62 08
AP80.80.48.V.DH	3 x 400 V	●	●	●	●	96 00 62 14
AP80.80.65/1V	3 x 400 V				●	96 00 61 97
AP80.80.65/1V	3 x 400 V	●			●	96 00 62 03
AP80.80.65/1.V.D	3 x 400 V	●	●		●	96 00 62 09
AP80.80.65/1.V.DH	3 x 400 V	●	●	●	●	96 00 62 15
AP80.80.65/2V	3 x 400 V				●	96 00 61 98
AP80.80.65/2V	3 x 400 V	●			●	96 00 62 04
AP80.80.65/2.V.D	3 x 400 V	●	●		●	96 00 62 10
AP80.80.65/2.V.DH	3 x 400 V	●	●	●	●	96 00 62 16
AP80.80.92/1V	3 x 400 V				●	96 00 61 99
AP80.80.92/1V	3 x 400 V	●			●	96 00 62 05
AP80.80.92/1.V.D	3 x 400 V	●	●		●	96 00 62 11
AP80.80.92/1.V.DH	3 x 400 V	●	●	●	●	96 00 62 17
AP80.80.92/2V	3 x 400 V				●	96 00 62 00
AP80.80.92/2V	3 x 400 V	●			●	96 00 62 06
AP80.80.92/2.V.D	3 x 400 V	●	●		●	96 00 62 12
AP80.80.92/2.V.DH	3 x 400 V	●	●	●	●	96 00 62 18
AP80.80.107V	3 x 400 V				●	96 00 62 01
AP80.80.107V	3 x 400 V	●			●	96 00 62 07
AP80.80.107.V.D	3 x 400 V	●	●		●	96 00 62 13
AP80.80.107.V.DH	3 x 400 V	●	●	●	●	96 00 62 19
AP80.100.48V	3 x 400 V				●	96 00 62 20
AP80.100.48V	3 x 400 V	●			●	96 00 62 26
AP80.100.48.V.D	3 x 400 V	●	●		●	96 00 62 32
AP80.100.48.V.DH	3 x 400 V	●	●	●	●	96 00 62 38
AP80.100.65/1V	3 x 400 V				●	96 00 62 21
AP80.100.65/1V	3 x 400 V	●			●	96 00 62 27
AP80.100.65/1.V.D	3 x 400 V	●	●		●	96 00 62 33
AP80.100.65/1.V.DH	3 x 400 V	●	●	●	●	96 00 62 39
AP80.100.65/2V	3 x 400 V				●	96 00 62 22
AP80.100.65/2V	3 x 400 V	●			●	96 00 62 28
AP80.100.65/2.V.D	3 x 400 V	●	●		●	96 00 62 34
AP80.100.65/2.V.DH	3 x 400 V	●	●	●	●	96 00 62 40
AP80.100.92/1V	3 x 400 V				●	96 00 62 23
AP80.100.92/1V	3 x 400 V	●			●	96 00 62 29
AP80.100.92/1.V.D	3 x 400 V	●	●		●	96 00 62 35
AP80.100.92/1.V.DH	3 x 400 V	●	●	●	●	96 00 62 41
AP80.100.92/2V	3 x 400 V				●	96 00 62 24
AP80.100.92/2V	3 x 400 V	●			●	96 00 62 30
AP80.100.92/2.V.D	3 x 400 V	●	●		●	96 00 62 36
AP80.100.92/2.V.DH	3 x 400 V	●	●	●	●	96 00 62 42
AP80.100.107V	3 x 400 V				●	96 00 62 25
AP80.100.107V	3 x 400 V	●			●	96 00 62 31
AP80.100.107.V.D	3 x 400 V	●	●		●	96 00 62 37
AP80.100.107.V.DH	3 x 400 V	●	●	●	●	96 00 62 43

## AP100 standard version

Pump type	Voltage	Moisture sensor	Cooling jacket	Horizontal version	10 m cable	Product no.
AP100.100.24	3 x 400 V				●	96 00 35 89
AP100.100.24	3 x 400 V	●			●	96 00 35 37
AP100.100.24.D	3 x 400 V	●	●		●	96 00 35 42
AP100.100.24.DH	3 x 400 V	●	●	●	●	96 00 35 73
AP100.100.32	3 x 400 V				●	96 00 35 90
AP100.100.32	3 x 400 V	●			●	96 00 35 38
AP100.100.32.D	3 x 400 V	●	●		●	96 00 35 43
AP100.100.32.DH	3 x 400 V	●	●	●	●	96 00 35 74
AP100.100.45	3 x 400 V				●	96 00 35 91
AP100.100.45	3 x 400 V	●			●	96 00 35 39
AP100.100.45.D	3 x 400 V	●	●		●	96 00 35 44
AP100.100.45.DH	3 x 400 V	●	●	●	●	96 00 35 75
AP100.100.54	3 x 400 V				●	96 00 35 92
AP100.100.54	3 x 400 V	●			●	96 00 35 40
AP100.100.54.D	3 x 400 V	●	●		●	96 00 35 45
AP100.100.54.DH	3 x 400 V	●	●	●	●	96 00 35 76
AP100.100.61	3 x 400 V				●	96 00 35 93
AP100.100.61	3 x 400 V	●			●	96 00 35 41
AP100.100.61.D	3 x 400 V	●	●		●	96 00 35 46
AP100.100.61.DH	3 x 400 V	●	●	●	●	96 00 35 77
AP100.100.80	3 x 400 V				●	96 00 37 34
AP100.100.80	3 x 400 V	●			●	96 00 37 42
AP100.100.80.D	3 x 400 V	●	●		●	96 00 37 50
AP100.100.80.DH	3 x 400 V	●	●	●	●	96 00 37 58
AP100.100.115	3 x 400 V				●	96 00 37 35
AP100.100.115	3 x 400 V	●			●	96 00 37 43
AP100.100.115.D	3 x 400 V	●	●		●	96 00 37 51
AP100.100.115.DH	3 x 400 V	●	●	●	●	96 00 37 59
AP100.100.130	3 x 400 V				●	96 00 37 36
AP100.100.130	3 x 400 V	●			●	96 00 37 44
AP100.100.130.D	3 x 400 V	●	●		●	96 00 37 52
AP100.100.130.DH	3 x 400 V	●	●	●	●	96 00 37 60
AP100.100.135	3 x 400 V				●	96 00 37 37
AP100.100.135	3 x 400 V	●			●	96 00 37 45
AP100.100.135.D	3 x 400 V	●	●		●	96 00 37 53
AP100.100.135.DH	3 x 400 V	●	●	●	●	96 00 37 61
AP100.150.80	3 x 400 V				●	96 00 37 38
AP100.150.80	3 x 400 V	●			●	96 00 37 46
AP100.150.80.D	3 x 400 V	●	●		●	96 00 37 54
AP100.150.80.DH	3 x 400 V	●	●	●	●	96 00 37 62
AP100.150.115	3 x 400 V				●	96 00 37 39
AP100.150.115	3 x 400 V	●			●	96 00 37 47
AP100.150.115.D	3 x 400 V	●	●		●	96 00 37 55
AP100.150.115.DH	3 x 400 V	●	●	●	●	96 00 37 63
AP100.150.130	3 x 400 V				●	96 00 37 40
AP100.150.130	3 x 400 V	●			●	96 00 37 48
AP100.150.130.D	3 x 400 V	●	●		●	96 00 37 56
AP100.150.130.DH	3 x 400 V	●	●	●	●	96 00 37 64
AP100.150.170	3 x 400 V				●	96 00 37 41
AP100.150.170	3 x 400 V	●			●	96 00 37 49
AP100.150.170.D	3 x 400 V	●	●		●	96 00 37 57
AP100.150.170.DH	3 x 400 V	●	●	●	●	96 00 37 65

## AP10 Ex-version

Pump type	Voltage	Control box with 0.8 m supply cable	Float switch	10 m cable	With plug	Product no.
AP10.50.12.3.Ex	3 x 400 V	●		●		96 00 25 31
AP10.50.12.3.Ex	3 x 400V			●		96 00 65 50
AP10.50.12.3.Ex	3 x 230 V	●		●		96 00 25 38

## AP30 Ex-version

Pump type	Voltage	Control box with 0.8 m supply cable	Float switch	10 m cable	With plug	Product no.
AP30.50.09.3.Ex	3 x 400 V			●		96 00 25 59
AP30.50.09.3.Ex	3 x 230 V			●		96 00 25 78
AP30.50.12.3.Ex	3 x 400 V			●		96 00 25 62
AP30.50.12.3.Ex	3 x 230 V			●		96 00 25 81

## AP51 Ex-version

Pump type	Voltage	Control box with 0.8 m supply cable	Float switch	With temperature sensors in the motor windings	10 m cable	With plug	Product no.
AP51.65.22.3.Ex	3 x 400 V				●		96 00 25 71
AP51.65.22.3.Ex	3 x 230 V				●		96 00 25 88

## AP65 Vortex Ex-version

Pump type	Voltage	Moisture sensor	Cooling jacket	Horizontal version	10 m cable	Product no.
AP65.65.12.1V.Ex	1 x 230 V				●	96 00 44 97
AP65.65.12.3V.Ex	3 x 400 V				●	96 00 44 73
AP65.100.24.V.Ex	3 x 400 V				●	96 00 63 23
AP65.100.24.V.Ex	3 x 400 V	●			●	96 00 63 28
AP65.100.32.V.Ex	3 x 400 V				●	96 00 63 24
AP65.100.32.V.Ex	3 x 400 V	●			●	96 00 63 29
AP65.100.45.V.Ex	3 x 400 V				●	96 00 63 25
AP65.100.45.V.Ex	3 x 400 V	●			●	96 00 63 30
AP65.100.61.V.Ex	3 x 400 V				●	96 00 63 26
AP65.100.61.V.Ex	3 x 400 V	●			●	96 00 63 31
AP65.100.130.V.Ex	3 x 400 V				●	96 00 63 27
AP65.100.130.V.Ex	3 x 400 V	●			●	96 00 63 32

## AP70 Ex-version

Pump type	Voltage	With temperature sensors in the motor windings	10 m cable	Product no.
AP70.80.09.3.Ex	3 x 400 V		●	96 00 25 91
AP70.80.09.3.Ex	3 x 230 V		●	96 00 26 02
AP70.80.13.3.Ex	3 x 400 V		●	96 00 25 94
AP70.80.13.3.Ex	3 x 230V		●	96 00 26 04
AP70.80.19.3.Ex	3 x 400 V		●	96 00 25 97
AP70.80.19.3.Ex	3 x 230 V		●	96 00 26 06
AP70.80.24.3.Ex	3 x 400 V		●	96 00 26 00
AP70.80.24.3.Ex	3 x 230 V		●	96 00 26 08

## AP80 Vortex Ex-version

Pump type	Voltage	Moisture sensor	Cooling jacket	Horizontal version	10 m cable	Product no.
AP80.80.10V.Ex	3 x 230 V				●	96 00 62 96
AP80.80.13V.Ex	3 x 230 V				●	96 00 62 97
AP80.80.20V.Ex	3 x 230 V				●	96 00 62 98
AP80.80.26V.Ex	3 x 230 V				●	96 00 62 99
AP80.80.10V.Ex	3 x 400 V				●	96 00 53 60
AP80.80.13V.Ex	3 x 400 V				●	96 00 53 61
AP80.80.20V.Ex	3 x 400 V				●	96 00 53 62
AP80.80.26V.Ex	3 x 400 V				●	96 00 53 63
AP80.80.48V.Ex	3 x 400 V				●	96 00 62 44
AP80.80.48V.Ex	3 x 400 V	●			●	96 00 62 50
AP80.80.48V.D.Ex	3 x 400 V	●	●		●	96 00 62 56
AP80.80.48V.DH.Ex	3 x 400 V	●	●	●	●	96 00 62 62
AP80.80.65/1V.Ex	3 x 400 V				●	96 00 62 45
AP80.80.65/1V.Ex	3 x 400 V	●			●	96 00 62 51
AP80.80.65/1V.D.Ex	3 x 400 V	●	●		●	96 00 62 57
AP80.80.65/1V.DH.Ex	3 x 400 V	●	●	●	●	96 00 62 63
AP80.80.65/2V.Ex	3 x 400 V				●	96 00 62 46
AP80.80.65/2V.Ex	3 x 400 V	●			●	96 00 62 52
AP80.80.65/2V.D.Ex	3 x 400 V	●	●		●	96 00 62 58
AP80.80.65/2V.DH.Ex	3 x 400 V	●	●	●	●	96 00 62 64
AP80.80.92/1V.Ex	3 x 400 V				●	96 00 62 47
AP80.80.92/1V.Ex	3 x 400 V	●			●	96 00 62 53
AP80.80.92/1V.D.Ex	3 x 400 V	●	●		●	96 00 62 59
AP80.80.92/1V.DH.Ex	3 x 400 V	●	●	●	●	96 00 62 65
AP80.80.92/2V.Ex	3 x 400 V				●	96 00 62 48
AP80.80.92/2V.Ex	3 x 400 V	●			●	96 00 62 54
AP80.80.92/2V.D.Ex	3 x 400 V	●	●		●	96 00 62 60
AP80.80.92/2V.DH.Ex	3 x 400 V	●	●	●	●	96 00 62 66
AP80.80.107V.Ex	3 x 400 V				●	96 00 62 49
AP80.80.107V.Ex	3 x 400 V	●			●	96 00 62 55
AP80.80.107V.D.Ex	3 x 400 V	●	●		●	96 00 62 61
AP80.80.107V.DH.Ex	3 x 400 V	●	●	●	●	96 00 62 67
AP80.100.48V.D.Ex	3 x 400 V	●	●		●	96 00 62 80
AP80.100.48V.DH.Ex	3 x 400 V	●	●	●	●	96 00 62 86
AP80.100.65/1V.Ex	3 x 400 V				●	96 00 62 69
AP80.100.65/1V.Ex	3 x 400 V	●			●	96 00 62 75
AP80.100.65/1V.D.Ex	3 x 400 V	●	●		●	96 00 62 81
AP80.100.65/1V.DH.Ex	3 x 400 V	●	●	●	●	96 00 62 87
AP80.100.65/2V.Ex	3 x 400 V				●	96 00 62 70
AP80.100.65/2V.Ex	3 x 400 V	●			●	96 00 62 76
AP80.100.65/2V.D.Ex	3 x 400 V	●	●		●	96 00 62 82
AP80.100.65/2V.DH.Ex	3 x 400 V	●	●	●	●	96 00 62 88
AP80.100.92/1V.Ex	3 x 400 V				●	96 00 62 71
AP80.100.92/1V.Ex	3 x 400 V	●			●	96 00 62 77
AP80.100.92/1V.D.Ex	3 x 400 V	●	●		●	96 00 62 83
AP80.100.92/1V.DH.Ex	3 x 400 V	●	●	●	●	96 00 62 89
AP80.100.92/2V.Ex	3 x 400 V				●	96 00 62 72
AP80.100.92/2V.Ex	3 x 400 V	●			●	96 00 62 78
AP80.100.92/2V.D.Ex	3 x 400 V	●	●		●	96 00 62 84
AP80.100.92/2V.DH.Ex	3 x 400 V	●	●	●	●	96 00 62 90
AP80.100.107V.Ex	3 x 400 V				●	96 00 62 73
AP80.100.107V.Ex	3 x 400 V	●			●	96 00 62 79
AP80.100.107V.D.Ex	3 x 400 V	●	●		●	96 00 62 85
AP80.100.107V.DH.Ex	3 x 400 V	●	●	●	●	96 00 62 91

## AP100 Ex-version

Pump type	Voltage	Moisture sensor	Cooling jacket	Horizontal version	10 m cable	Product no.
AP100.100.24.Ex	3 x 400 V				●	96 00 35 94
AP100.100.24.Ex	3 x 400 V	●			●	96 00 35 47
AP100.100.24.D.Ex	3 x 400 V	●	●		●	96 00 35 52
AP100.100.24.DH.Ex	3 x 400 V	●	●	●	●	96 00 35 78
AP100.100.32.Ex	3 x 400 V				●	96 00 35 95
AP100.100.32.Ex	3 x 400 V	●			●	96 00 35 48
AP100.100.32.D.Ex	3 x 400 V	●	●		●	96 00 35 53
AP100.100.32.DH.Ex	3 x 400 V	●	●	●	●	96 00 35 79
AP100.100.45.Ex	3 x 400 V				●	96 00 35 96
AP100.100.45.Ex	3 x 400 V	●			●	96 00 35 49
AP100.100.45.D.Ex	3 x 400 V	●	●		●	96 00 35 54
AP100.100.45.DH.Ex	3 x 400 V	●	●	●	●	96 00 35 80
AP100.100.54.Ex	3 x 400 V				●	96 00 35 97
AP100.100.54.Ex	3 x 400 V	●			●	96 00 35 50
AP100.100.54.D.Ex	3 x 400 V	●	●		●	96 00 35 55
AP100.100.54.DH.Ex	3 x 400 V	●	●	●	●	96 00 35 81
AP100.100.61.Ex	3 x 400 V				●	96 00 35 98
AP100.100.61.Ex	3 x 400 V	●			●	96 00 35 51
AP100.100.61.D.Ex	3 x 400 V	●	●		●	96 00 35 56
AP100.100.61.DH.Ex	3 x 400 V	●	●	●	●	96 00 35 82
AP100.100.80.Ex	3 x 400 V				●	96 00 37 78
AP100.100.80.Ex	3 x 400 V	●			●	96 00 37 86
AP100.100.80.D.Ex	3 x 400 V	●	●		●	96 00 37 94
AP100.100.80.DH.Ex	3 x 400 V	●	●	●	●	96 00 38 02
AP100.100.115.Ex	3 x 400 V				●	96 00 37 79
AP100.100.115.Ex	3 x 400 V	●			●	96 00 37 87
AP100.100.115.D.Ex	3 x 400 V	●	●		●	96 00 37 95
AP100.100.115.DH.Ex	3 x 400 V	●	●	●	●	96 00 38 03
AP100.100.130.Ex	3 x 400 V				●	96 00 37 80
AP100.100.130.Ex	3 x 400 V	●			●	96 00 37 88
AP100.100.130.D.Ex	3 x 400 V	●	●		●	96 00 37 96
AP100.100.130.DH.Ex	3 x 400 V	●	●	●	●	96 00 38 04
AP100.100.135.Ex	3 x 400 V				●	96 00 37 81
AP100.100.135.Ex	3 x 400 V	●			●	96 00 37 89
AP100.100.135.D.Ex	3 x 400 V	●	●		●	96 00 37 97
AP100.100.135.DH.Ex	3 x 400 V	●	●	●	●	96 00 38 05
AP100.150.80.Ex	3 x 400 V				●	96 00 37 82
AP100.150.80.Ex	3 x 400 V	●			●	96 00 37 90
AP100.150.80.D.Ex	3 x 400 V	●	●		●	96 00 37 98
AP100.150.80.DH.Ex	3 x 400 V	●	●	●	●	96 00 38 06
AP100.150.115.Ex	3 x 400 V				●	96 00 37 83
AP100.150.115.Ex	3 x 400 V	●			●	96 00 37 91
AP100.150.115.D.Ex	3 x 400 V	●	●		●	96 00 37 99
AP100.150.115.DH.Ex	3 x 400 V	●	●	●	●	96 00 38 07
AP100.150.130.Ex	3 x 400 V				●	96 00 37 84
AP100.150.130.Ex	3 x 400 V	●			●	96 00 37 92
AP100.150.130.D.Ex	3 x 400 V	●	●		●	96 00 38 00
AP100.150.130.DH.Ex	3 x 400 V	●	●	●	●	96 00 38 08
AP100.150.170.Ex	3 x 400 V				●	96 00 37 85
AP100.150.170.Ex	3 x 400 V	●			●	96 00 37 93
AP100.150.170.D.Ex	3 x 400 V	●	●		●	96 00 38 01
AP100.150.170.DH.Ex	3 x 400 V	●	●	●	●	96 00 38 09





V7 07 86 74 03 03	<b>GB</b>
Repl. V7 07 86 74 03 01	

Subject to alterations.