



Trusted in 160 Countries for High Quality



KOSHIN EUROPE OFFICE

KOSHIN LTD. JAPAN
HEAD QUARTERS

KOSHIN LITIAN PUMP
(NINGBO) CO., LTD.
NINGBO KOSHIN MOTOR CO., LTD.



KOSHIN (THAILAND)
CO.,LTD.



Headquarters (Kyoto, Japan)



Koshin Litian Pump (Ningbo) Co.,Ltd.



Ningbo Koshin Motor Co.,Ltd.



Koshin (Thailand) Co.,Ltd.



HIDELS PUMPS	4
TRASH PUMPS.....	14
SEMI TRASH PUMPS	17
HIGH PRESSURE PUMPS	18
AGRO MATE (THERMOPLASTIC PUMPS) ...	20
HIGH PRESSURE WASHER.....	21
PABOOL PUMPS	22
PONSTAR (SUBMERSIBLE PUMPS).....	24
PONDY (SUBMERSIBLE PUMPS)	29
GEAR PUMPS (GL SERIES)	32
CHANGE MASTER, FS PUMPS	33
GEAR PUMPS (GB/GC SERIES).....	34
FILL PUMPS	35
DRUM PUMPS.....	36
PACO-PET, MAMA-AUTO	38
MISTER AUTO (GARDEN SPRAYERS)	39
GARDEN MASTER (DRY CELL BATTERY SPRAYERS)	40
GROUND MASTER (BACKPACK MANUAL SPRAYERS) ...	40
KIRI SEN-NIN (BATTERY SPRAYERS)	41
GARDEN SPRAYER (BACK PACK TYPE ENGINE SPRAYER) ..	42
GARDEN SPRAYER (POWER SPRAYERS)	43
ECARL (BATTERY WINCHES)	44
NEW BILGE KING	47
REVOLVEX PUMPS.....	48
FS PUMPS (FOR SEAWATER)	51



KOSHIN AMERICA CORP.



KOSHIN MEXICO OFFICE



We Guarantee All Specifications

▼ Explanation of pictogram



GARDENING



IRRIGATION



SPRINKLER



FIRE FIGHTING



WASHING



HIGH LIFT



FISH TANK



ON BOAT



200 L DRUM CAN



SILICON CARBIDE MECHANICAL SEAL



QUIET



CIRCULATION



CONSTRUCTION



SHALLOW WELL



FISH FARM



SEA WATER



CHEMICALS



HOME SWIMMING POOL



OIL (VISCOSITY)



RECHARGEABLE BATTERY



DRY CELL BATTERY



ENVIRONMENT



PORTABLE & POWERFUL

New! Original KOSHIN Engine High Performance & Economy

(1) Low fuel consumption. The original Koshin engine achieves the lowest fuel consumption.

Low Fuel Consumption (SEV-80X case)

Comparison of Fuel Consumption

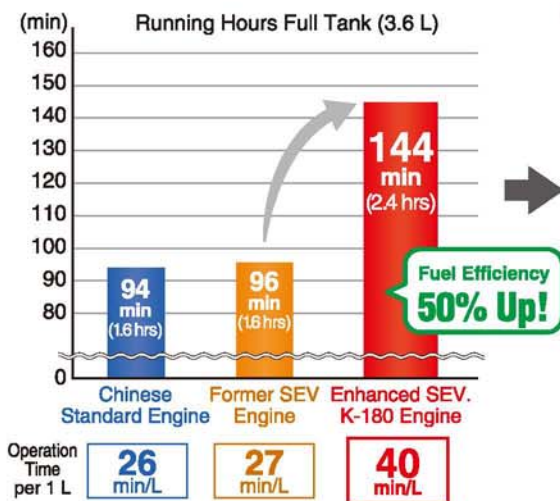

Comparison of Running Cost (Pump + Fuel)

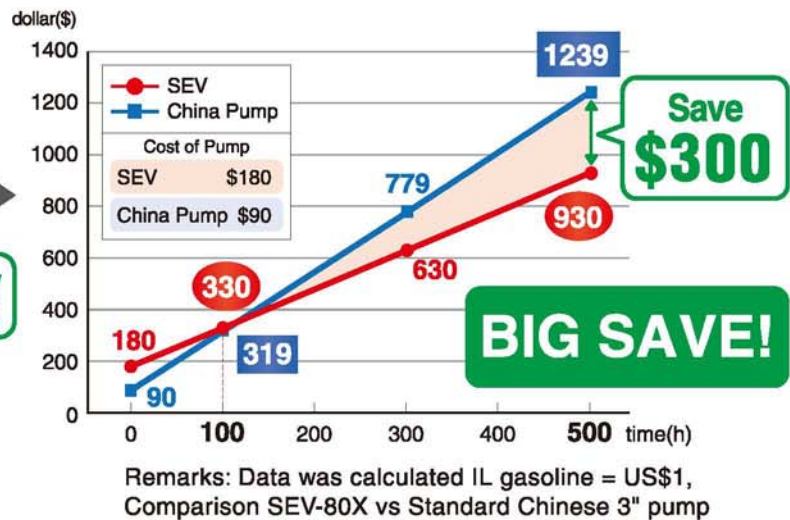

Low Vibration

Comfortable in use after reducing engine vibration.

(2) Low Vibration

Comfortable in use after reducing engine vibration.

Guaranteed Performance

Koshin guarantees 8 m suction head and specifications.

(3) Guaranteed performance

Koshin guarantees 8 m suction head and specifications.

Competitive Price & Guaranteed Quality Powered by Koshin Engine

GUARANTEED

- Engine & Pump spare parts service!
- Specification & Quality!
- Sales support!!



SEV-50X

■ Performance Curve

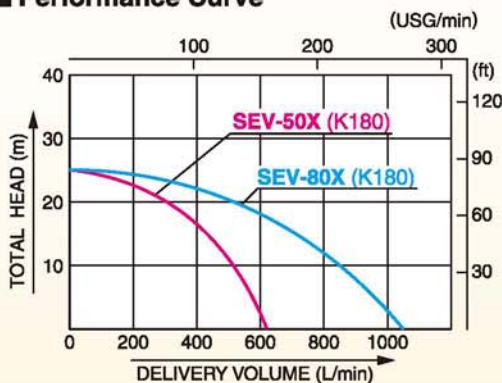

SEV-80X

■ Specifications

Model	SEV-50X	SEV-80X
Connection Dia	50 mm (2")	80 mm (3")
Connection Thread	Outer Pipe Thread BSP	
Total Head	27 m (90 ft)	
Delivery Volume	620 L/min (163 USG/min)	1050 L/min (277 USG/min)
Max. Suction Head	8 m (26 ft)	
Type	Forced Air-cooled 4-stroke Gasoline Engine	
Model	Koshin K180	
Exhaust Volume	179 cc	
Rated Output	3.1 kW (4.2 PS) / 3600 rpm	
Fuel	Automotive Unleaded Gasoline	
Fuel Tank Capacity	3.6 L (0.95 USG)	
Continuous Operating Time	Approx. 2.6 hrs	Approx. 2.4 hrs
Starting Method	Recoil Starter	
Standard Accessories	1 Strainer, 3 Hose Bands, 2 Hose Couplings,	1 Engine Tool Set
Gross Weight	27.2 kg (59.9 lbs)	30.7 kg (67.6 lbs)
Dimensions LxWxH (mm)	504 x 401 x 411	543 x 426 x 458
Packing Unit	1	

*For the purpose of improvement, specifications are subject to changes without notice.

Competitive Price & Guaranteed Quality Powered by Koshin Engine

• **SIC**

Silicon Carbide Mechanical Seal 4-5 times more durable than standard carbon ceramic mechanical seal.

• **FCD**

Spheroidal graphite iron casting for Impeller & Volute Casing 10 times more erosion resistance than standard FC or cast iron.

■ **Outstanding Features**

- Suitable for sandy and muddy water usage
- Particles up to 8 mm can be pumped through
- Guaranteed suction head of 8 meters
- Long bolt assembly for easy maintenance

■ **Performance Curve**

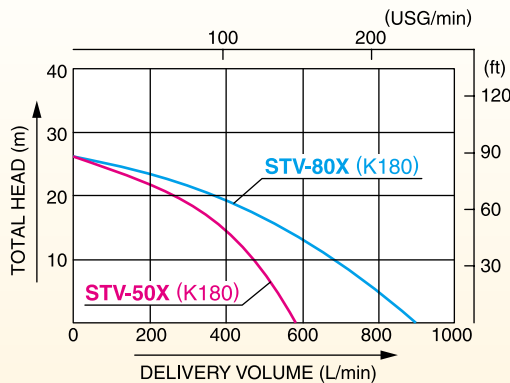

GUARANTEED

- Engine & Pump spare parts service!
- Specification & Quality!
- Sales support!!

Solid Sizes

Max. 8mm



■ **Specifications**

	Model	STV-50X	STV-80X
PUMP	Connection Dia	50 mm (2")	80 mm (3")
	Connection Thread	Outer Pipe Thread BSP	
	Total Head	26 m (85 ft)	
	Delivery Volume	580 L/min (153 USG/min)	900 L/min (238 USG/min)
	Max. Suction Head	8 m (26 ft)	
ENGINE	Type	Forced Air-cooled 4-stroke Gasoline Engine	
	Model	Koshin K180	
	Exhaust Volume	179 cc	
	Rated Output	3.1 kW (4.2 PS) / 3600 rpm	
	Fuel	Automotive Unleaded Gasoline	
	Fuel Tank Capacity	3.6 L (0.95 USG)	
	Continuous Operating Time	Approx. 2.6 hrs	Approx. 2.4 hrs
	Starting Method	Recoil Starter	
Standard Accessories	1 Strainer, 2 Hose Couplings, 3 Hose Bands, 1 Engine Tool Set, 1 Spanner		
Gross Weight	31 kg (68.3 lbs)	32.9 kg (72.5 lbs)	
Dimensions LxWxH (mm)	554 x 400 x 471	593 x 425 x 528	
Packing Unit	1		

*For the purpose of improvement, specifications are subject to changes without notice.

Competitive Price & Guaranteed Quality Powered by Koshin Engine

- Koshin Original Engine.
- All aluminum die casting pump housing, impeller and volutes for light weight and portability.
- Easy maintenance.
- High Grade carbon/ceramic mechanical seal.

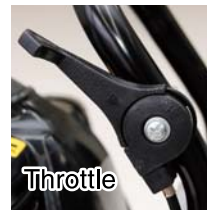

Economy and Ecology

"50:1" 2 stroke mixed fuel, friendly to the earth and your wallet!

SEV-25L is designed only for "50:1" 2 stroke mixed fuel which is environmentally-friendly in terms of exhaust. Also, you can save a half of engine oil compared with the usual "25:1" 2 stroke mixed fuel.

GUARANTEED

- Engine & Pump spare parts service!
- Specification & Quality!
- Sales support!!



Performance Curve

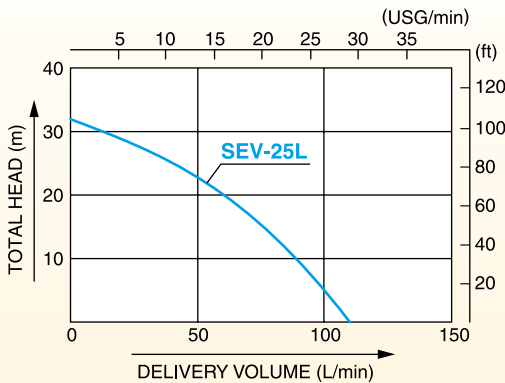

Note: Performance ratings are guaranteed minimum, not inflated maximum.



Specifications

Model		SEV-25L
PUMP	Connection Dia	25 mm (1")
	Connection Thread	Outer Pipe Thread BSP
	Total Head	32 m (105 ft)
	Delivery Volume	110 L/min (29 USG/min)
	Max. Suction Head	8 m (26 ft)
ENGINE	Type	Forced Air-cooled 2-stroke Gasoline Engine
	Model	Koshin KC26
	Exhaust Volume	26 cc
	Rated Output	0.70 kW (0.93 PS) / 7500 rpm
	Fuel	2 Stroke Mixed Gas and Oil (50:1)
	Fuel Tank Capacity	0.6 L (0.16 USG)
	Continuous Operating Time	Approx. 50 min
	Starting Method	Recoil Starter
Standard Accessories	1 Strainer, 2 Hose Couplings, 3 Hose Bands, 1 Engine Tool Set	
Gross Weight	7.7 kg (16.9 lbs)	
Dimensions LxWxH (mm)	368 x 273 x 338	
Packing Unit	1	

*For the purpose of improvement, specifications are subject to changes without notice.

Light Weight 2 Stroke Engine Pumps



Super Light



Performance Curve

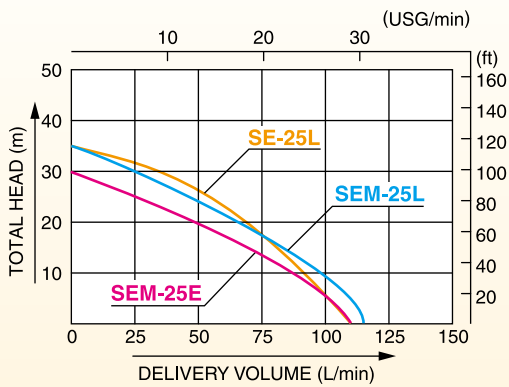

Specifications

	Model	SE-25L	SEM-25L	SEM-25E
PUMP	Connection Dia	25 mm (1")		
	Connection Thread	Outer Pipe Thread BSP		
	Total Head	35 m (115 ft)	35 m (115 ft)	30 m (98 ft)
	Delivery Volume	110 L/min (29 USG/min)	115 L/min (30 USG/min)	110 L/min (29 USG/min)
	Max. Suction Head	8 m (26 ft)		
ENGINE	Type	Forced Air-cooled 2-stroke Gasoline Engine		
	Model	Subaru EC025GR	Mitsubishi TU26	Mitsubishi TLE20
	Exhaust Volume	24.5 cc	25.6 cc	19.8 cc
	Rated Output	0.55 kW (0.75 PS) / 6000 rpm	—	—
	Max. Output	0.88 kW (1.2 PS) / 7000 rpm	1.03 kW (1.4 PS) / 7500 rpm	0.6 kW (0.8 PS) / 7000 rpm
	Fuel	2 Stroke Mixed Gas and Oil (25:1)		
	Fuel Tank Capacity	0.6 L (0.16 USG)	0.6 L (0.16 USG)	0.45 L (0.12 USG)
	Continuous Operating Time	Approx. 50 min	Approx. 50 min	
	Starting Method	Recoil Starter		
	Standard Accessories	1 Strainer, 2 Hose Couplings, 3 Hose Bands, 1 Engine Tool Set		
Gross Weight	6.0 kg (13.2 lbs)	6.5 kg (14.3 lbs)		
Dimensions L×W×H (mm)	300 × 225 × 333	330 × 245 × 325	305 × 265 × 333	
Packing Unit	1			

Up to 50% Fuel Saving & Noise Reduction* Double Life Span

* Fuel consumption and engine noise are half of 2 stroke engine.



Performance Curve

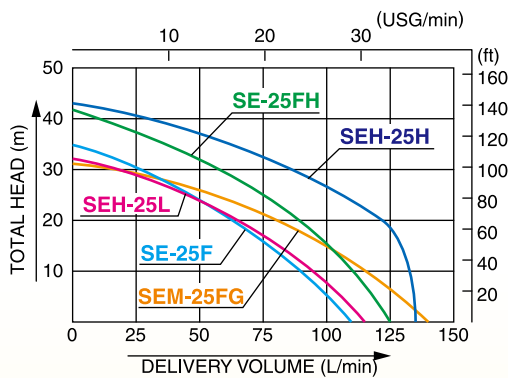

Available 25 mm Hose Set

N-Type Hose Set

- Washing of agriculture & construction machinery



- 1 Delivery hose <8 m (26 ft)>
- 1 Nozzle (Jet)

R-Type Hose Set

- Washing of agriculture machinery
- Water sprinkling to the field



- 1 Delivery hose <8 m (26 ft)>
- 1 Nozzle (Jet & Mist)

New Spray Nozzle



SJ-20

- Large volume of spraying water
- 1 Coupling set <20 mm (¾")>
- 1 Hose nipple <20 mm (¾") × 15 mm (½")>



Specifications

	Model	SEH-25L	SEH-25H	SE-25F	SE-25FH	SEM-25FG	
PUMP	Connection Dia	25 mm (1")					
	Connection Thread	Outer Pipe Thread BSP					
	Total Head	32 m (105 ft)	43 m (141 ft)	35 m (115 ft)	42 m (138 ft)	31 m (102 ft)	
	Delivery Volume	115 L/min (30 USG/min)	135 L/min (36 USG/min)	110 L/min (29 USG/min)	125 L/min (33 USG/min)	140 L/min (37 USG/min)	
	Max. Suction Head	8 m (26 ft)					
ENGINE	Type	Forced Air-cooled 4-stroke Gasoline Engine					
	Model	Honda GX25	Honda GXH50	Subaru EH025	Subaru EH035	Mitsubishi GT241	
	Exhaust Volume	25 cc	49 cc	24.5 cc	33.5 cc	79.6 cc	
	Rated Output	—	—	0.55 kW (0.75 PS) / 7000 rpm	0.81 kW (1.1 PS) / 7000 rpm	1.3 kW (1.8 PS) / 3600 rpm	
	Max. Output	0.81 kW (1.1 PS) / 7000 rpm	1.8 kW (2.5 PS) / 7000 rpm	0.81 kW (1.1 PS) / 7000 rpm	1.18 kW (1.6 PS) / 7000 rpm	1.8 kW (2.4 PS)	
	Fuel	Automotive Unleaded Gasoline					
	Fuel Tank Capacity	0.55 L (0.14 USG)	0.9 L (0.24 USG)	0.5 L (0.13 USG)	0.65 L (0.17 USG)	1.6 L (0.42 USG)	
	Continuous Operating Time	Approx. 1 hrs			Approx. 50 min		Approx. 2 hrs
	Starting Method	Recoil Starter					
	Standard Accessories	1 Strainer, 2 Hose Couplings, 3 Hose Bands, 1 Engine Tool Set					
Gross Weight	7 kg (15.4 lbs)	13.5 kg (29.7 lbs)	6.6 kg (14.5 lbs)	9.5 kg (20.9 lbs)	18 kg (39.7 lbs)		
Dimensions LxWxH (mm)	375 × 243 × 320	385 × 311 × 453	358 × 255 × 335	378 × 273 × 350	485 × 325 × 385		
Packing Unit	1						

Complete Range of Water Pumps Powered by Honda Engine

- Highly effective mechanical seal made with special carbon ceramics provides extra durability.
- Entire unit is protected by sturdy rollover pipe frame.
- Strong and lightweight die-cast aluminum pump.



Performance Curve

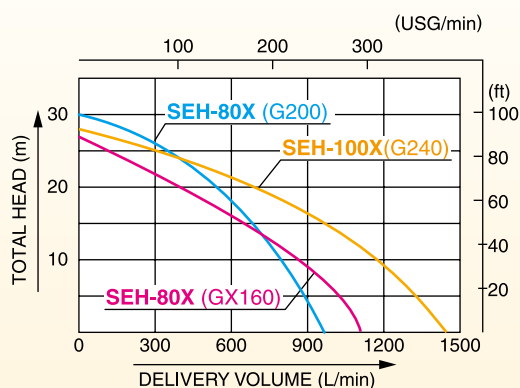
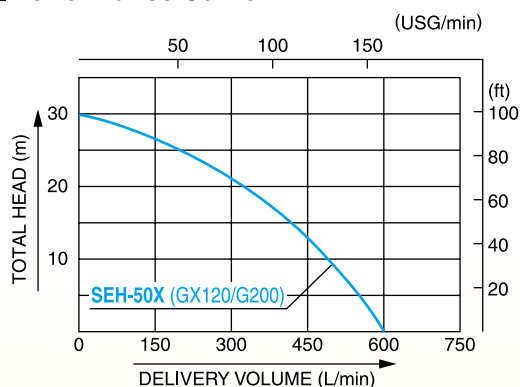

SEH-50X

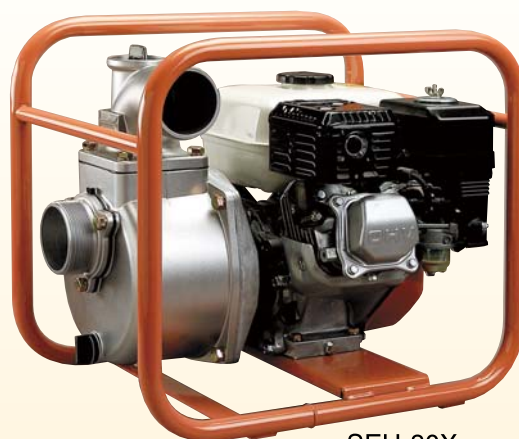

SEH-80X

Specifications

Model	SEH-50X	SEH-80X	SEH-100X
Connection Dia	50 mm (2")	80 mm (3")	100 mm (4")
Connection Thread	Outer Pipe Thread BSP		
Total Head	30 m (98 ft)	27 m (88 ft)	27 m (88 ft)
Delivery Volume	600 L/min (158 USG/min)	640 L/min (169 USG/min)	1100 L/min (290 USG/min)
Max. Suction Head	8 m (26 ft)		
Type	Forced Air-cooled 4-stroke Gasoline Engine		
Model	Honda GX120	Honda GX160	Honda GX160
Exhaust Volume	118 cc	163 cc	163 cc
Rated Output	2.1 kW (2.9 PS) / 3600 rpm	2.9 kW (3.9 PS) / 3600 rpm	2.9 kW (3.9 PS) / 3600 rpm
Max. Output	2.6 kW (3.5 PS) / 3600 rpm	3.6 kW (4.9 PS) / 4000 rpm	3.6 kW (4.9 PS) / 3600 rpm
Fuel	Automotive Unleaded Gasoline		
Fuel Tank Capacity	2.0 L (0.53 USG)	3.1 L (0.8 USG)	3.1 L (0.82 USG)
Continuous Operating Time	Approx. 2 hrs	Approx. 2 hrs	Approx. 2 hrs
Starting Method	Recoil Starter		
Standard Accessories	1 Strainer, 2 Hose Couplings, 3 Hose Bands, 1 Engine Tool Set		
Gross Weight	22 kg (48.5 lbs)	27 kg (59.5 lbs)	30 kg (66.1 lbs)
Dimensions LxWxH (mm)	483 × 375 × 376	527 × 429 × 535	525 × 389 × 458
Packing Unit	1		

Strong & Durable Subaru Engine

- Highly effective mechanical seal made with special carbon ceramics provides extra durability.
- Entire unit is protected by sturdy rollover pipe frame.
- Strong and lightweight die-cast aluminum pump.



Performance Curve

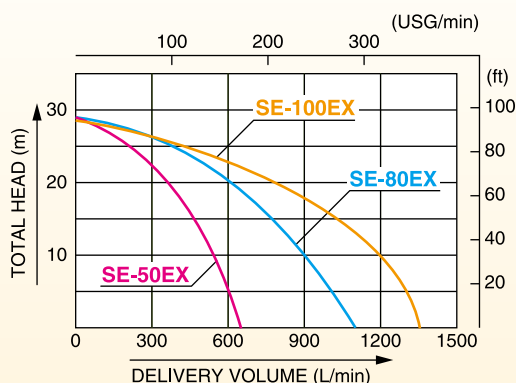
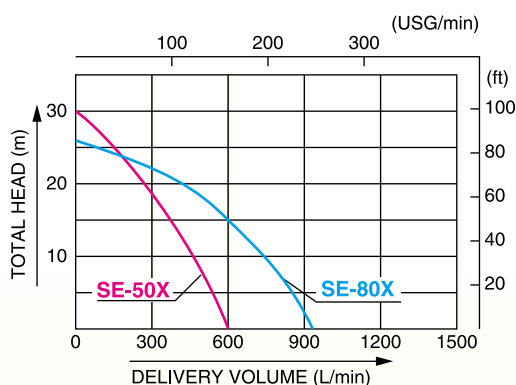

SE-80EX



SE-100EX

Specifications

Model	SE-50X	SE-80X	SE-50EX	SE-80EX	SE-100EX	
PUMP	Connection Dia	50 mm (2")	80 mm (3")	50 mm (2")	80 mm (3")	100 mm (4")
	Connection Thread	Outer Pipe Thread BSP				
	Total Head	30 m (98 ft)	26 m (85 ft)	28 m (92 ft)	28 m (92 ft)	27 m (89 ft)
	Delivery Volume	600 L/min (158 USG/min)	930 L/min (246 USG/min)	650 L/min (172 USG/min)	1100 L/min (290 USG/min)	1350 L/min (356 USG/min)
	Max. Suction Head	8 m (26 ft)				
ENGINE	Type					Forced Air-cooled 4-stroke Gasoline Engine
	Model	Subaru EY15-3D	Subaru EY20-3D	Subaru EX16	Subaru EX17	Subaru EX27
	Exhaust Volume	143 cc	183 cc	169 cc	169 cc	265 cc
	Rated Output	2.0 kW (2.7 PS) / 3600 rpm	2.6 kW (3.5 PS) / 3600 rpm	2.2 kW (3.0 PS) / 3600 rpm	2.9 kW (4.0 PS) / 3600 rpm	5.1 kW (7.0 PS) / 3600 rpm
	Max. Output	2.6 kW (3.5 PS) / 4000 rpm	3.7 kW (5.0 PS) / 4000 rpm	3.2 kW (4.3 PS) / 4000 rpm	4.2 kW (5.7 PS) / 4000 rpm	6.6 kW (9.0 PS) / 4000 rpm
	Fuel	Automotive Unleaded Gasoline				
	Fuel Tank Capacity	2.8 L (0.74 USG)	3.8 L (1.00 USG)	3.2 L (0.84 USG)	3.2 L (0.84 USG)	5.6 L (1.48 USG)
	Continuous Operating Time	Approx. 2.8 hrs	Approx. 3 hrs	Approx. 2.5 hrs		Approx. 2.1 hrs
	Starting Method	Recoil Starter				
	Standard Accessories	1 Strainer, 2 Hose Couplings, 3 Hose Bands, 1 Engine Tool Set				
Gross Weight	23 kg (50.7 lbs)	35 kg (77.1 lbs)	27 kg (59.5 lbs)	33 kg (72.7 lbs)	57 kg (125 lbs)	
Dimensions LxWxH (mm)	484 × 330 × 420	525 × 370 × 472	504 × 401 × 411	530 × 405 × 465	670 × 477 × 669	
Packing Unit	1					

Powered by Durable Mitsubishi Engine

- Highly effective mechanical seal made with special carbon ceramics provides extra durability.
- Entire unit is protected by sturdy rollover pipe frame.
- Strong and lightweight die-cast aluminum pump.



SEM-40FG



SEM-80G

Performance Curve

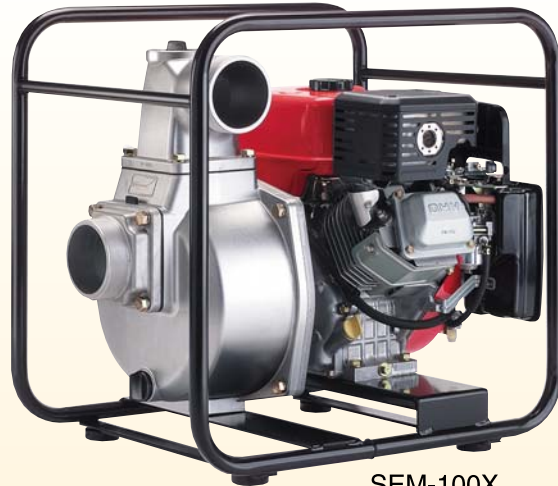
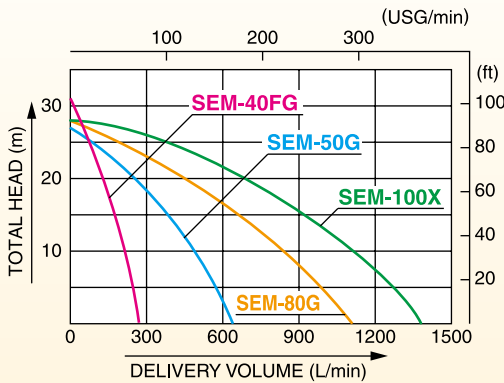

SEM-100X

Specifications

	Model	SEM-40FG	SEM-50G	SEM-80G	SEM-100X
PUMP	Connection Dia	40 mm (1½")	50 mm (2")	80 mm (3")	100 mm (4")
	Connection Thread	Outer Pipe Thread BSP			
	Total Head	31 m (102 ft)	27 m (88 ft)	28 m (92 ft)	28 m (92 ft)
	Delivery Volume	270 L/min (71 USG/min)	640 L/min (169 USG/min)	1100 L/min (290 USG/min)	1380 L/min (364 USG/min)
	Max. Suction Head	8 m (26 ft)			
ENGINE	Type	Forced Air-cooled 4-stroke Gasoline Engine			
	Model	Mitsubishi GT241	Mitsubishi GT400	Mitsubishi GT600	Mitsubishi GM231PN
	Exhaust Volume	79.6 cc	126 cc	181 cc	215 cc
	Rated Output	1.3 kW (1.8 PS) / 3600 rpm	2.1 kW (2.8 PS) / 3600 rpm	3.3 kW (4.5 PS) / 3600 rpm	3.6 kW (5.0 PS) / 3600 rpm
	Max. Output	1.8 kW (2.4 PS)	2.9 kW (4.0 PS)	4.4 kW (6.0 PS)	5.1 kW (7.0 PS)
	Fuel	Automotive Unleaded Gasoline			
	Fuel Tank Capacity	1.6 L (0.42 USG)	2.5 L (0.66 USG)	3.8 L (1.00 USG)	4.5 L (1.19 USG)
	Continuous Operating Time	Approx. 2 hrs		Approx. 3 hrs	
	Starting Method	Recoil Starter			
	Standard Accessories	1 Strainer, 2 Hose Couplings, 3 Hose Bands, 1 Engine Tools Set			
Gross Weight	21 kg (46.3 lbs)	26 kg (57.3 lbs)	33 kg (72.7 lbs)	53 kg (116.8 lbs)	
Dimensions LxWxH (mm)	450 × 330 × 397	500 × 395 × 415	525 × 420 × 488	670 × 477 × 669	
Packing Unit	1				

Kerosene Engine Pumps



Diesel Engine Pumps



Performance Curve

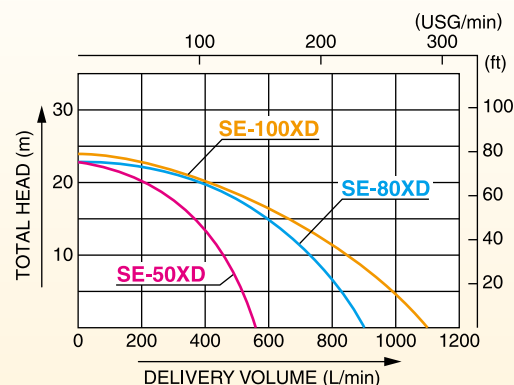
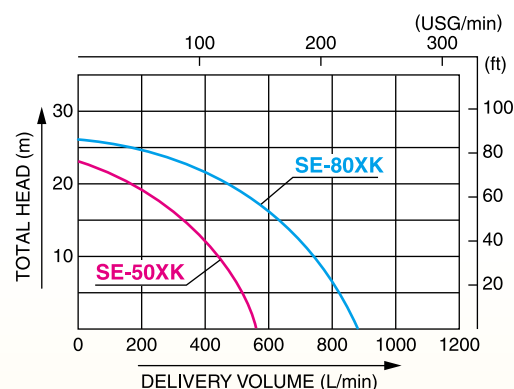

Specifications

Model	SE-50XK	SE-80XK	SE-50XD	SE-80XD	SE-100XD	
PUMP	Connection Dia	50 mm (2")	80 mm (3")	50 mm (2")	80 mm (3")	100 mm (4")
	Connection Thread	Outer Pipe Thread BSP				
	Total Head	23 m (75 ft)	26 m (85 ft)	23 m (75 ft)		24 m (79 ft)
	Delivery Volume	560 L/min (148 USG/min)	880 L/min (232 USG/min)	560 L/min (148 USG/min)	900 L/min (238 USG/min)	1100 L/min (290 USG/min)
Max. Suction Head	8 m (26 ft)					
ENGINE	Type	Air-cooled 4-cycle Kerosene Engine		Air-cooled 4-cycle Diesel Engine		
	Model	Subaru EY15-3DK	Subaru EY20-3DK	Subaru DY23-2D		Subaru DY27-2D
	Exhaust Volume	143 cc	183 cc	230 cc		265 cc
	Rated Output	1.6 kW (2.2 PS) / 3600 rpm	2.3 kW (3.1 PS) / 3600 rpm	3.1 kW (4.2 PS) / 3600 rpm		3.7 kW (5.0 PS) / 3600 rpm
	Max. Output	2.4 kW (3.3 PS) / 4000 rpm	3.2 kW (4.3 PS) / 4000 rpm	3.5 kW (4.8 PS) / 3600 rpm		4.4 kW (6.0 PS) / 3600 rpm
	Fuel	Kerosene (Automotive unleaded gasoline (starting))		Diesel Light Oil		
	Fuel Tank Capacity	Kerosene: 2.6 L (0.68 USG) Gasoline: 0.13 L (0.03 USG)		Kerosene: 3.4 L (0.90 USG) Gasoline: 0.17 L (0.04 USG)		3.2 L (0.84 USG)
	Continuous Operating Time	Approx. 2.5 hrs		Approx. 3.5 hrs	Approx. 3 hrs	Approx. 2.5 hrs
	Starting Method	Recoil Starter				
Standard Accessories	1 Strainer, 2 Hose Couplings, 3 Hose Bands, 1 Engine Tool Set					
Gross Weight	25 kg (55.1 lbs)	34 kg (74.9 lbs)	47 kg (103 lbs)	50 kg (110 lbs)	64 kg (141 lbs)	
Dimensions LxWxH (mm)	479 × 352 × 420	529 × 419 × 477	573 × 413 × 500	573 × 413 × 500	664 × 445 × 698	
Packing Unit	1					



HEAVY DUTY

Koshin Trash Pumps

•Excellent Seal Durability

Conventional mechanical seal using carbon ceramic is replaced by silicon carbide (SiC) seal. SiC seal is developed by Koshin and we are the first manufacturer to use such durable material in Japan.

•Thoughtful Design

Special plug designed on impeller allows easy removal.
Simply insert any rod and twist to separate impeller from its casing.
No special tool required.

•Light Weight & Compact Design

Conventional trash pumps are very bulky and heavy, some more than 100 kg in weight. KTR-100X, the largest of all, weights only 81 kg.
The compact design takes up smaller space and is portable.

•High Self-priming Performance

Special structure is designed to ensure high capacity self-priming performance. Koshin trash pumps give excellent performance and durability.

Easy & Quick Maintenance

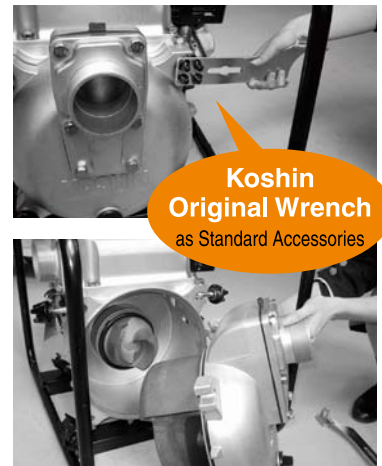

Special Material for Koshin Trash Pumps

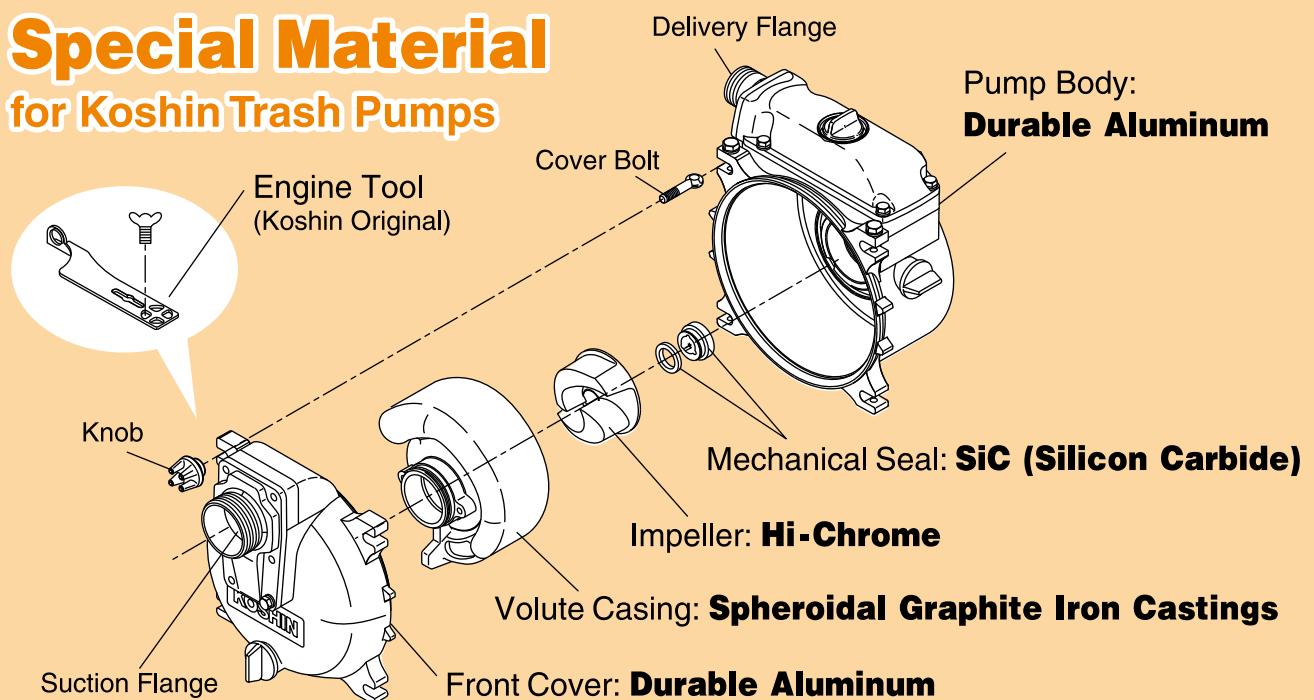

Heavy Duty Trash Pumps Powered by Honda & Mitsubishi Engine

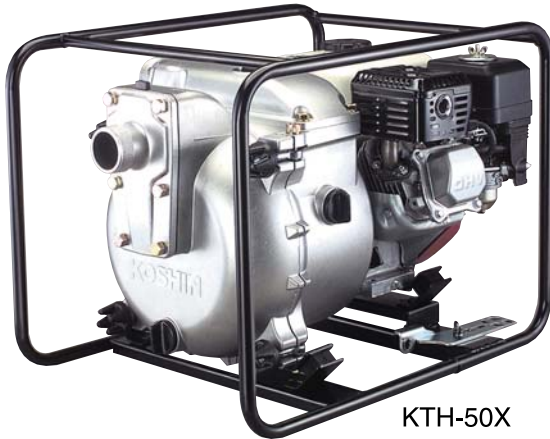

KTH-50X



KTM-80X

Performance Curve

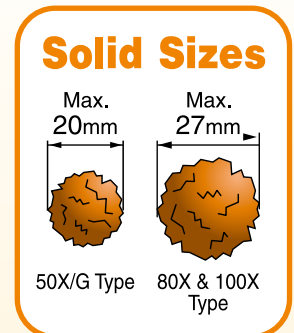
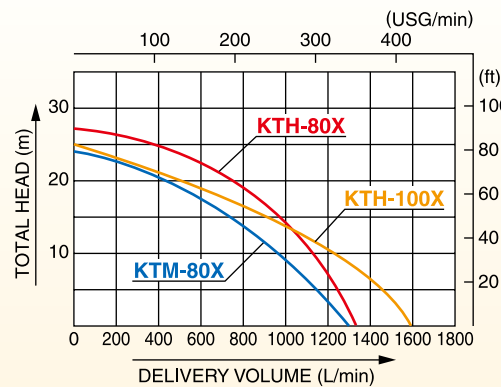
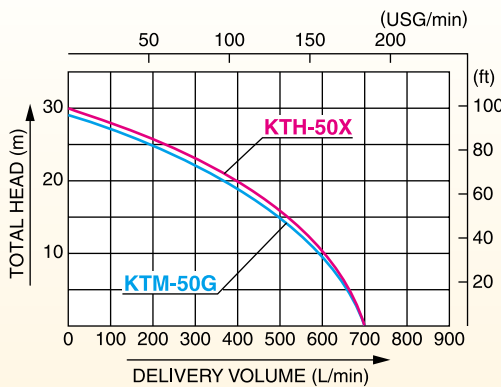

Specifications

Model	KTH-50X	KTH-80X	KTH-100X	KTM-50G	KTM-80X
Connection Dia	50 mm (2")	80 mm (3")	100 mm (4")	50 mm (2")	80 mm (3")
Connection Thread	Outer Pipe Thread BSP				
Total Head	30 m (98 ft)	27 m (89 ft)	25 m (82 ft)	28 m (92 ft)	24 m (79 ft)
Delivery Volume	700 L/min (185 USG/min)	1340 L/min (354 USG/min)	1600 L/min (422 USG/min)	700 L/min (185 USG/min)	1300 L/min (343 USG/min)
Max. Suction Head	8 m (26 ft)				
Material for Mechanical Seal	SiC (Silicon Carbide) × SiC				
Material for Impeller	Hi-Chrome				
Material for Volute	Spheroidal Graphite Iron Castings				
Type	Forced Air-cooled 4-stroke Gasoline Engine				
Model	Honda GX160	Honda GX240	Honda GX340	Mitsubishi GT600	Mitsubishi GM291
Exhaust Volume	163 cc	270 cc	337 cc	181 cc	296 cc
Rated Output	2.9 kW (4.0 PS) / 3600 rpm	4.6 kW (6.3 PS) / 3600 rpm	5.8 kW (7.9 PS) / 3600 rpm	3.3 kW (4.5 PS) / 3600 rpm	4.4 kW (6.0 PS) / 3600 rpm
Max. Output	3.6 kW (4.9 PS) / 3600 rpm	5.9 kW (8.0 PS) / 3600 rpm	7.1 kW (9.7 PS) / 3600 rpm	4.4 kW (6.0 PS) / 4000 rpm	5.9 kW (8.0 PS) / 4000 rpm
Fuel	Automotive Unleaded Gasoline				
Fuel Tank Capacity	3.1 L (0.82 USG)	5.3 L (1.40 USG)	6.1 L (1.61 USG)	3.8 L (1.0 USG)	6.0 L (1.58 USG)
Continuous Operating Time	Approx. 2.2 hrs	Approx. 2.5 hrs	Approx. 2 hrs		Approx. 3 hrs
Starting Method	Recoil Starter				
Standard Accessories	1 Strainer, 2 Hose Couplings, 3 Hose Bands, 1 Engine Tool Set				
Gross Weight	51 kg (112 lbs)	64 kg (141 lbs)	86 kg (189 lbs)	55 kg (121 lbs)	68 kg (150 lbs)
Dimensions LxWxH (mm)	646 × 488 × 509	711 × 506 × 570	780 × 570 × 652	646 × 488 × 509	721 × 536 × 582
Packing Unit	1				

Heavy Duty Trash Pumps Powered by Robin Engine

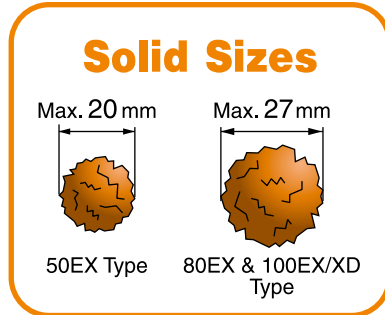

Performance Curve

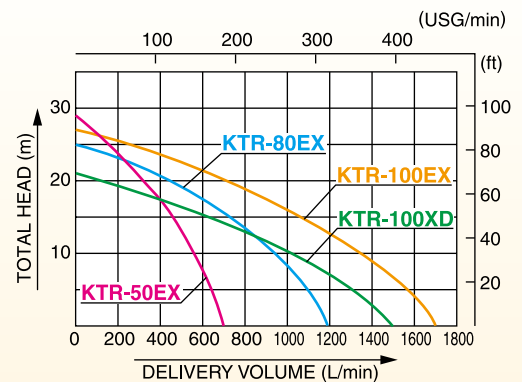

Specifications

	Model	KTR-50EX	KTR-80EX	KTR-100EX	KTR-100XD	
PUMP	Connection Dia	50 mm (2")	80 mm (3")	100 mm (4")		
	Connection Thread	Outer Pipe Thread BSP				
	Total Head	29 m (95 ft)	25 m (82 ft)	28 m (92 ft)	21 m (69 ft)	
	Delivery Volume	700 L/min (185 USG/min)	1190 L/min (314 USG/min)	1700 L/min (449 USG/min)	1500 L/min (396 USG/min)	
	Max. Suction Head	8 m (26 ft)				
	Material for Mechanical Seal	SiC (Silicon Carbide) × SiC				
	Material for Impeller	Hi-Chrome				
ENGINE	Material for Volute	Spheroidal Graphite Iron Castings				
	Type	Forced Air-cooled 4-stroke Gasoline Engine			Forced Air-cooled 4-stroke Diesel Engine	
	Model	Subaru EX17	Subaru EX27	Subaru EX40	Subaru DY41	
	Exhaust Volume	169 cc	265 cc	404 cc	412 cc	
	Rated Output	2.9 kW (4.0 PS) / 3600 rpm	5.1 kW (7.0 PS) / 3600 rpm	7.0 kW (9.5 PS) / 3600 rpm	5.5 kW (7.5 PS) / 3600 rpm	
	Max. Output	4.2 kW (5.7 PS) / 4000 rpm	6.6 kW (9.0 PS) / 4000 rpm	10.3 kW (14.0 PS) / 3600 rpm	6.3 kW (8.5 PS) / 3600 rpm	
	Fuel	Automotive Unleaded Gasoline			Diesel Light Oil	
	Fuel Tank Capacity	3.2 L (0.84 USG)	5.6 L (1.48 USG)	6.8 L (1.79 USG)	4.5 L (1.18 USG)	
	Continuous Operating Time	Approx. 2 hrs	Approx. 2.1 hrs	Approx. 1.6 hrs	Approx. 2.3 hrs	
	Starting Method	Recoil starter				
Standard Accessories	1 Strainer, 2 Hose Couplings, 3 Hose Bands, 1 Engine Tool Set					
Gross Weight	53 kg (117 lbs)	64 kg (141 lbs)	90 kg (198 lbs)	117 kg (258 lbs)		
Dimensions L×W×H (mm)	646 × 488 × 509	711 × 500 × 570	780 × 592 × 652	883 × 528 × 677		
Packing Unit	1					

Economical Trash Pumps For Sandy & Muddy Water Applications

- **Silicon Carbide Mechanical Seal (SiC).**
4 to 5 times more durable than standard carbon ceramic mechanical seal.
- Spheroidal graphite iron casting for impeller and casing.
10 times more corrosion resistant than standard FC or cast iron.
- Impeller can be removed easily without special tool.
- Long bolt assembly for easy maintenance.



STR-50EX

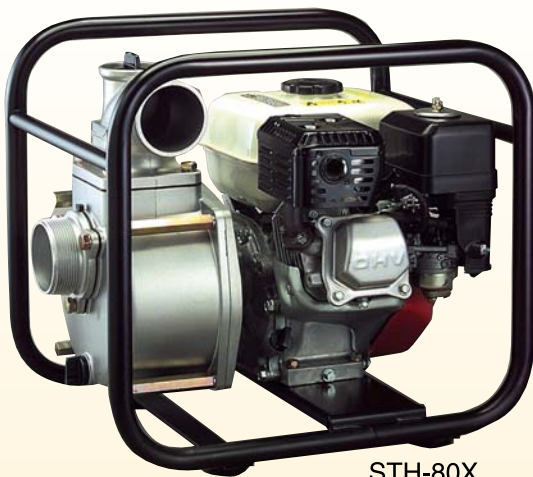

STH-80X

Performance Curve

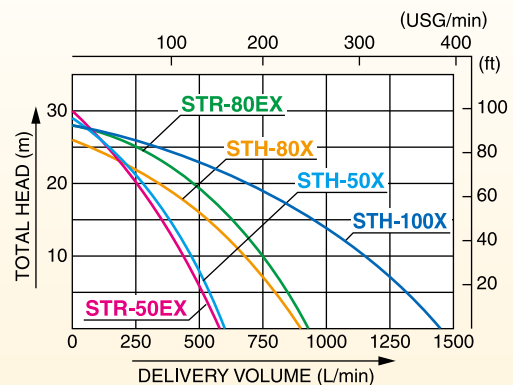

Specifications

	Model	STH-50X	STH-80X	STH-100X	STR-50EX	STR-80EX
PUMP	Connection Dia	50 mm (2")	80 mm (3")	100 mm (4")	50 mm (2")	80 mm (3")
	Connection Thread	Outer Pipe Thread BSP				
	Total Head	29 m (95 ft)	26 m (85 ft)	28 m (92 ft)	30 m (98 ft)	28 m (92 ft)
	Delivery Volume	600 L/min (158 USG/min)	900 L/min (238 USG/min)	1450 L/min (383 USG/min)	580 L/min (153 USG/min)	930 L/min (246 USG/min)
	Max. Suction Head	8 m (26 ft)				
ENGINE	Type	Forced Air-cooled 4-stroke Gasoline Engine				
	Model	Honda GX120	Honda GX160	Honda GX240	Subaru EX16	Subaru EX17
	Exhaust Volume	118 cc	163 cc	270 cc	169 cc	169 cc
	Rated Output	2.1 kW (2.9 PS) / 3600 rpm	2.9 kW (4.0 PS) / 3600 rpm	4.6 kW (6.3 PS) / 3600 rpm	2.2 kW (3.0 PS) / 3600 rpm	2.9 kW (4.0 PS) / 3600 rpm
	Max. Output	2.6 kW (3.5 PS) / 3600 rpm	3.6 kW (4.9 PS) / 3600 rpm	5.9 kW (8.0 PS) / 3600 rpm	3.2 kW (4.3 PS) / 4000 rpm	4.2 kW (5.7 PS) / 4000 rpm
	Fuel	Automotive Unleaded Gasoline				
	Fuel Tank Capacity	2.0 L (0.53 USG)	3.1 L (0.82 USG)	5.3 L (1.40 USG)	3.6 L (0.95 USG)	3.2 L (0.84 USG)
	Continuous Operating Time	Approx. 3 hrs			Approx. 2 hrs	
	Starting Method	Recoil starter				
	Standard Accessories	1 Strainer, 2 Hose Couplings, 3 Hose Bands, 1 Engine Tool Set, 1 Spanner				
Gross Weight	25 kg (55.1 lbs)	35 kg (77.1 lbs)	64 kg (141 lbs)	28 kg (61.7 lbs)	34 kg (74.9 lbs)	
Dimensions LxWxH (mm)	500 x 395 x 415	525 x 389 x 473	665 x 472 x 655	506 x 402 x 429	530 x 405 x 405	
Packing Unit	1					



HIGH PRESSURE

Suitable for Sprinkler System & Fire Fighting

- Compact & lightweight high pressure pump
- 3 ways delivery flange [2"×1, 1"×2] (SERM-50V)



SEM-50V SERM-50V



SEM-50V



SEM-50V Image

Specifications

	SEM-50V	SERM-50V	
PUMP	Connection Dia	50 mm (2")	Suction: 50 mm (2") Delivery: 50 mm (2") / 25 mm (1")
	Connection Thread	Outer Pipe Thread BSP	
	Total Head	50 m (164 ft)	90 m (295 ft)
	Delivery Volume	500 L/min (132 USG/min)	
	Max. Suction Head	8 m (26 ft)	
ENGINE	Type	Air-cooled 4-cycle Gasoline Engine	
	Model	Mitsubishi GM 132 Hi-Revolution	Mitsubishi GM 182 Hi-Revolution
	Exhaust Volume	126 cc	181 cc
	Rated Output	2.1 kW (2.8 PS) / 3600 rpm	3.3 kW (4.5 PS) / 3600 rpm
	Max. Output	2.9 kW (4.0 PS) / 4800 rpm	4.4 kW (6.0 PS) / 4800 rpm
	Fuel	Automotive Unleaded Gasoline	
	Fuel Tank Capacity	2.5 L (0.66 USG)	3.5 L (0.92 USG)
	Continuous Operating Time	Approx. 2 hrs	
	Starting Method	Recoil Starter	
	Standard Accessories	1 Strainer 3 Hose Bands 1 Hose Coupling 1 Quick Coupling 1 Engine Tool	1 Strainer 3 Hose Bands (φ 60) 2 Hose Bands (φ 32) 1 Coupling Set (50 mm) 1 Closing Plate (50 mm) 2 Nipples (25 mm) 1 Quick Coupling 1 Engine Tool
Gross Weight	28 kg (61.7 lbs)	38 kg (84 lbs)	
Dimensions LxWxH (mm)	510 × 402 × 440	555 × 450 × 468	
Packing Unit	1		



SERM-50V

Performance Curve

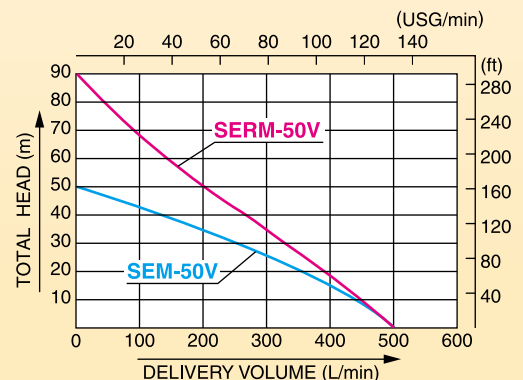

Pumps Suitable for Sprinkler System



Performance Curve

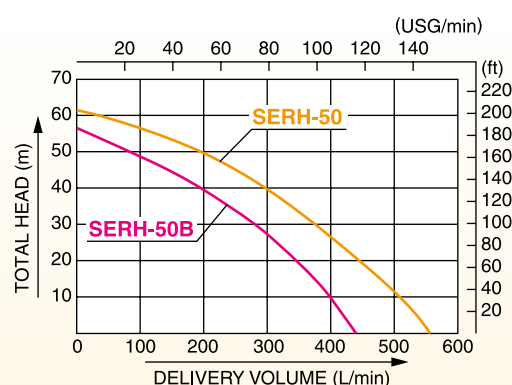
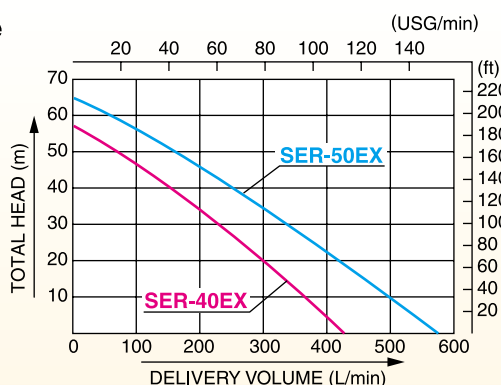

Specifications

Model		SER-40EX	SER-50EX	SERH-50B	SERH-50
PUMP	Connection Dia	IN 50 mm (2") OUT 40 mm (1½")	IN 65 mm (2½") OUT 50 mm (2")	IN 50 mm (2") OUT 50 mm (2")	IN 65 mm (2½") OUT 50 mm (2")
	Connection Thread	Outer Pipe Thread BSP			
	Total Head	57 m (187 ft)	65 m (213 ft)	57 m (187 ft)	62 m (203 ft)
	Delivery Volume	430 L/min (113 USG/min)	570 L/min (150 USG/min)	440 L/min (116 USG/min)	560 L/min (148 USG/min)
	Max. Suction Head	8 m (26 ft)			
ENGINE	Type	Air-cooled 4-cycle Gasoline Engine			
	Model	Subaru EX17	Subaru EX27	Honda GX160	Honda GX240
	Exhaust Volume	169 cc	265 cc	163 cc	270 cc
	Rated Output	2.9 kW (4.0 PS) / 3600 rpm	5.1 kW (7.0 PS) / 3600 rpm	2.9 kW (3.9 PS) / 3600 rpm	4.6 kW (6.3 PS) / 3600 rpm
	Max. Output	4.2 kW (5.7 PS) / 4000 rpm	6.6 kW (9.0 PS) / 4000 rpm	3.6 kW (4.9 PS) / 3600 rpm	5.9 kW (8.0 PS) / 3600 rpm
	Fuel	Automotive Unleaded Gasoline			
	Fuel Tank Capacity	3.2 L (0.84 USG)	5.6 L (1.48 USG)	3.1 L (0.82 USG)	5.3 L (1.40 USG)
	Continuous Operating Time	Approx. 2.0 hrs	Approx. 2.5 hrs	Approx. 2 hrs	Approx. 2.5 hrs
	Starting Method	Recoil Starter			
Standard Accessories	1 Coupling Set (40 mm) 1 Coupling Set (50 mm) 2 Hose Bands (φ60) 1 Hose Band (φ48) 1 Strainer (50 mm) 1 Engine Tool Set	1 Coupling Set (50 mm) 1 Coupling Set (65 mm) 2 Hose Bands (φ80) 1 Hose Band (φ60) 1 Strainer (65 mm) 1 Engine Tool Set	2 Coupling Set 3 Hose Bands (φ60) 1 Strainer 1 Engine Tool Set	1 Coupling Set (50 mm) 1 Coupling Set (65 mm) 2 Hose Bands (φ80) 1 Hose Band (φ60) 1 Strainer (65 mm) 1 Engine Tool Set	
Gross Weight	35 kg (77.1 lbs)	46 kg (101 lbs)	34 kg (74.9 lbs)	46 kg (101 lbs)	
Dimensions LxWxH (mm)	535 × 405 × 440	600 × 485 × 530	535 × 405 × 440	568 × 482 × 518	
Packing Unit	1				



POLYETHYLENE PUMP BODY

For Seawater, Fertilizer

- Superior material used.
 - PET (Polyethylene Terephthalate) for pump casing, impeller and volute casing.
 - EPDM and Carbon Ceramic for mechanical seal.
 - SUS for all bolts and washers.
- Powered by strong and durable engine.



PGH-50



PGM-50G

Specifications

	Model	PGH-50	PGM-50G
PUMP	Connection Dia	50 mm (2")	
	Connection Thread	Outer Pipe Thread BSP	
	Total Head	26 m (85 ft)	21 m (68 ft)
	Max. Suction Head	8 m (26 ft)	
	Delivery Volume	560 L/min (148 USG/min)	540 L/min (143 USG/min)
	Material for Mechanical Seal	Ceramic Carbon	
	Max. Pressure	0.26 MPa	0.21 MPa
	Type	Forced Air-cooled 4-stroke Gasoline Engine	
	Model	Honda GX120	Mitsubishi GT400
	Exhaust Volume	118 cc	126 cc
ENGINE	Rated Output	2.1 kW (2.9 PS) / 3600 rpm	2.1 kW (2.8 PS) / 3600 rpm
	Max. Output	2.6 kW (3.5 PS) / 3600 rpm	2.9 kW (4.0 PS)
	Fuel	Automotive Unleaded Gasoline	
	Fuel Tank Capacity	2.0 L (0.53 USG)	2.5 L (0.66 USG)
	Continuous Operating Time	Approx. 2 hrs	
	Starting Method	Recoil Starter	
	Standard Accessories	2 Nipples, 1 Engine Tool Set	
	Gross Weight	21 kg (46.3 lbs)	23 kg (50.7 lbs)
	Dimensions LxWxH (mm)	520 x 428 x 448	511 x 407 x 439
	Packing Unit	1	

Performance Curve

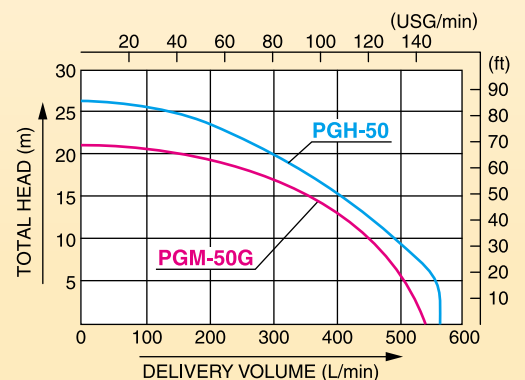

Powerful High Pressure with 15 MPa (JCE-1510)

- **For washing farm equipments**
Suitable for cleaning a tractor, combine and rice planting machine.
- **Easy to clean agricultural equipments after use**
It can be operated in any field and endble to get water from water channel nearby.
- **Double function for peeling bark off and washing (JCE-1510)**
The rotary nozzle can easily to remove hard barks.



New



JCE-1107DX



JCE-1510

■ Specifications

Model		JCE-1107DX	JCE-1510
PUMP	Max. Pressure	11 MPa (110 kgf/cm ²)	15 MPa (150 kgf/cm ²)
	Max. Volume	7 L/min	10 L/min
	Recommended Feed-water	Clear water at 5 – 40 °C	
	Max. Suction Head	1.0 m	1.5 m
	Necessary Volume of Engine Oil	80 cc	200 cc
ENGINE	Type	Air Forced 4 Stroke OHV Gasoline Engine	
	Model	Koshin K100	Koshin K210
	Total Exhaust Volume	98 cc	212 cc
	Fuel	Automotive Unleaded Gasoline	
	Fuel Tank Capacity	2.0 L	3.6 L
	Engine Oil	SAE 10W-30	
	Necessary Volume of Engine Oil	350 cc	600 cc
	Accessories	1 Gun, 1 Straight/Fan shape nozzle, 1 Delivery hose (10 m), 1 Suction hose (3m), 1 Strainer	1 Gun, 1 Delivery hose (10 m), 1 Strainer, 1 Suction hose (3 m), 6 Interchangeable nozzle: (1) point-blank (2) 15° (3) 25° (4) 40° (5) Detergent nozzle (6) Rortary nozzle
Gross Weight	27 kg (59.5 lbs)	42 kg (92.6 lbs)	
Dimensions LxWxH (mm)	490 × 460 × 615	660 × 685 × 770	
Packing Unit	1		



PABOOL PUMPS

Pabool Pumps are Designed for Sprinkler System & General Irrigation



SU-40Z



SU-50Z

Performance Curve

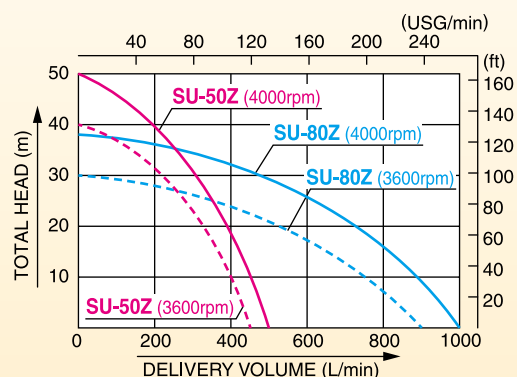
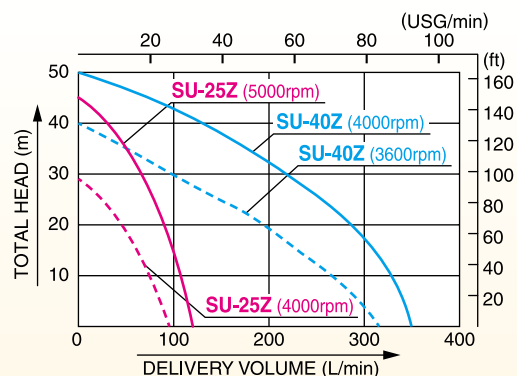

Specifications

Model	SU-25Z		SU-40Z		SU-50Z		SU-80Z	
Connection Dia	25 mm (1")		40 mm (1½")		50 mm (2")		80 mm (3")	
Connection Thread	Outer Pipe Thread BSP							
Revolution	4000 rpm	5000 rpm	3600 rpm	4000 rpm	3600 rpm	4000 rpm	3600 rpm	4000 rpm
Total Head	29 m (95 ft)	45 m (148 ft)	40 m (131 ft)	50 m (164 ft)	40 m (131 ft)	50 m (164 ft)	30 m (98 ft)	38 m (124 ft)
Delivery Volume	96 L/min (25 USG/min)	120 L/min (32 USG/min)	315 L/min (83 USG/min)	350 L/min (92 USG/min)	450 L/min (119 USG/min)	500 L/min (132 USG/min)	900 L/min (238 USG/min)	1000 L/min (264 USG/min)
Output	1.5 kW (2 PS)	2.2 kW (3 PS)	4.0 kW (3 PS)	3.7 kW (5 PS)	3.7 kW (5 PS)	5.5 kW (7.5 PS)	5.5 kW (7.5 PS)	7.5 kW (10 PS)
Standard Accessories	1 Strainer, 2 Couplings, 3 Hose Bands							
Gross Weight	33 kg (72.7 lbs)		24 kg (52.9 lbs)		31 kg (68.3 lbs)		36 kg (79.3 lbs)	
Dimensions LxWxH (mm)	663 x 461 x 245		384 x 469 x 284		535 x 404 x 310		535 x 437 x 453	
Packing Unit	4		2		2		2	

Powerful Pressure & Enhanced Durability



SU-50V

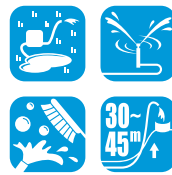

SU-80V

Double Life Span Durability

Mechanical Seal

Standard type → **SU-V series**

Impeller

Standard type (4 blades) → **SU-V series (6 blades)**

Performance Curve

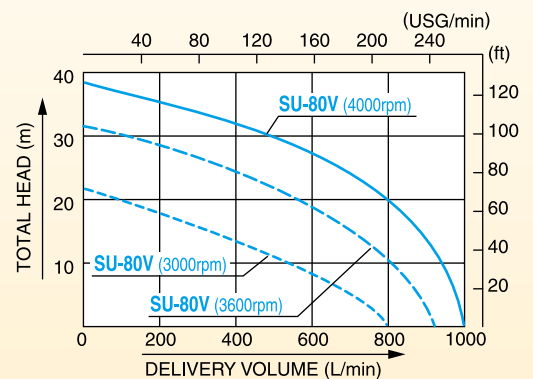
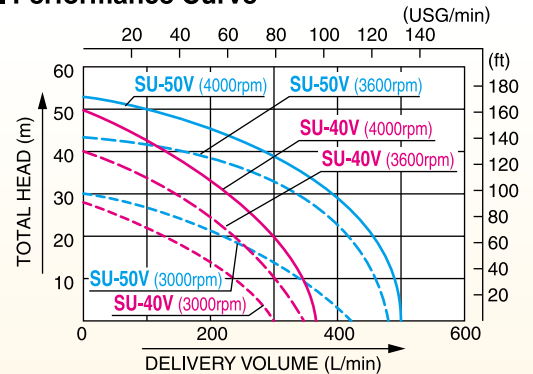

Chart Shows Co-relation Between Motor Rotation and Pulley Diameter

Hz	Model		SU-40V • SU-50V • SU-80V					
	Motor Poles (Revolution)	Revolution	3000		3600		4000	
			mm	inch	mm	inch	mm	inch
50	2P (2880 rpm)		81	3½	96	4	106	4½
	4P (1430 rpm)		161	6½	191	8	211	9
	6P (960 rpm)		235	9	291	12	326	13
60	2P (2880 rpm)		66	2½	81	3½	91	3½
	4P (1430 rpm)		129	5	161	6½	91	8
	6P (960 rpm)		191	8	235	9	261	10

Specifications

Model	SU-40V			SU-50V			SU-80V		
Connection Dia	40 mm (1½")			50 mm (2")			80 mm (3")		
Connection Thread	Outer Pipe Thread BSP								
Revolution	3000 rpm	3600 rpm	4000 rpm	3000 rpm	3600 rpm	4000 rpm	3000 rpm	3600 rpm	4000 rpm
Total Head	28 m (91 ft)	40 m (131 ft)	50 m (164 ft)	30 m (98 ft)	42 m (137 ft)	53 m (173 ft)	21 m (68 ft)	31 m (101 ft)	38 m (124 ft)
Delivery Volume	300 L/min (79 USG/min)	350 L/min (92 USG/min)	370 L/min (98 USG/min)	430 L/min (113 USG/min)	480 L/min (127 USG/min)	500 L/min (132 USG/min)	800 L/min (211 USG/min)	920 L/min (243 USG/min)	1000 L/min (264 USG/min)
Max. Suction Head	7 m (23 ft)	8 m (26 ft)		7 m (23 ft)	8 m (26 ft)		7 m (23 ft)	8 m (26 ft)	
Output	1.5 kW (2 PS)	2.2 kW (3 PS)	3.7 kW (5 PS)	2.2 kW (3 PS)	3.7 kW (5 PS)	5.5 kW (7.5 PS)	3.7 kW (5 PS)	5.5 kW (7.5 PS)	7.5 kW (10 PS)
Standard Accessories	1 Strainer, 2 Couplings, 3 Hose Bands								
Gross Weight	13.5 kg (29.7 lbs)			16 kg (35.3 lbs)			24 kg (52.9 lbs)		
Dimensions LxWxH (mm)	360 × 212 × 240			392 × 250 × 280			434 × 277 × 378		
Packing Unit	1								

HEAVY DUTY SUBMERSIBLE PUMPS

Powerful Pumps for Heavy Duties

- Double mechanical seals in oil chamber filled with liquid paraffin prevents damage from dry running.
- Liquid paraffin is used in the shaft seal. Water is not contaminated even in case of oil leakage.
- Thermal protector cuts off circuit in case of overload during operation.



PB-55011



Effective Motor Cooling System

Water is channeled through the outer wall to cool the motor for maximum endurance.

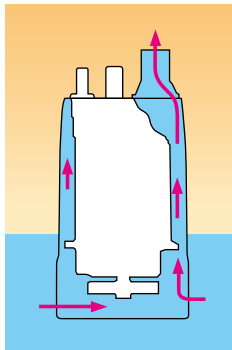

Specifications

Model		PB-55011	PB-55022	PB-65011
PUMP	Connection Dia	50 mm (2")		
	Total Head	10 m (32.8 ft)		
	Delivery Volume	290 L/min (76 USG/min)		
	Voltage	AC 110 V	AC 220 V	AC 110 V
MOTOR	Frequency	50 Hz		60 Hz
	Rated Current	7.3 A	3.6 A	8.7 A
	Output	400 W		
	Consumption	760 W	680 W	750 W
	Revolution	2900 rpm		3400 rpm
	Model	Induction Motor		
	Power Cord	10 m (32.8 ft) / 6 m (10.7 ft)		6 m (10.7 ft)
	Standard Accessories	1 Rope (5 m (16.4 ft)), 1 Hose Band		
Gross Weight	32 kg (70.5 lbs)	33 kg (72.7 lbs)		
Dimensions LxWxH (mm)	543 x 280 x 524			
Packing Unit	2			

Performance Curve

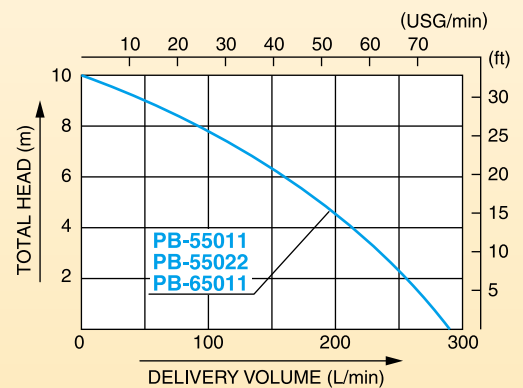

*Starting current is three times higher than rated current.

Great Durability



PX-55022

For Residual Water Up to 1 mm

- Designed for application in narrow access drainage especially in manhole or bottom pit.



PXL-52522

Applications

- Drainage of underground water
- Disposal of residual water from roof tank of buildings, swimming pools, etc.
- Construction site
- Pond / Aquarium usage
- Irrigation
- Home / Domestic application

Performance Curve

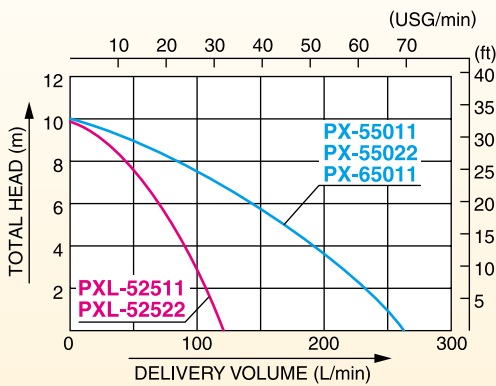

*Starting current is three times higher than rated current.

Invertible Delivery Flange

Just 2 bolts delivery flange is inverted



Specifications

Model		PX-55011	PX-55022	PX-65011	PXL-52511	PXL-52522	
PUMP	Connection Dia	50 mm (2")			25 mm (1")		
	Total Head	10 m (32.8 ft)					
	Delivery Volume	260 L/min (68 USG/min)			120 L/min (31 USG/min)		
MOTOR	Voltage	AC 110 V	AC 220 V	Single 110 V	AC 110 V	AC 220 V	
	Frequency	50 Hz		60 Hz	50 Hz		
	Rated Current	6.5 A	3.2 A	6.5 A	6.0 A	2.9 A	
	Output	400 W					
	Consumption	580 W	620 W	700 W	590 W	540 W	
	Revolution	2900 rpm		3400 rpm	2900 rpm		
	Model	Condenser Induction Motor					
	Power Cord	10 m (32.8 ft)	5 m (16.4 ft)	6 m (19.7 ft)	10 m (32.8 ft)		
Standard Accessories		1 Hose Band, 1 Rope (5 m (16.4 ft)), 1 Hose Nipple		1 Rope (5 m (16.4 ft))	1 Hose Band, 1 Hose Nipple, 1 Coupling, 1 Coupling Packing, 1 Rope (5 m (16.4ft))		
Gross Weight		25 kg (55.1 lbs)			30 kg (66.1 lbs)		
Dimensions LxWxH (mm)		258 x 500 x 424			515 x 270 x 432		
Packing Unit						2	

Triple Life Span Impeller Compared with Former Product

•Durable and long life time

Impeller is manufactured from a blended rubber compound providing maximum wear resistance up to three times over cast iron.

Maximal life-span and super hard mechanical seal.

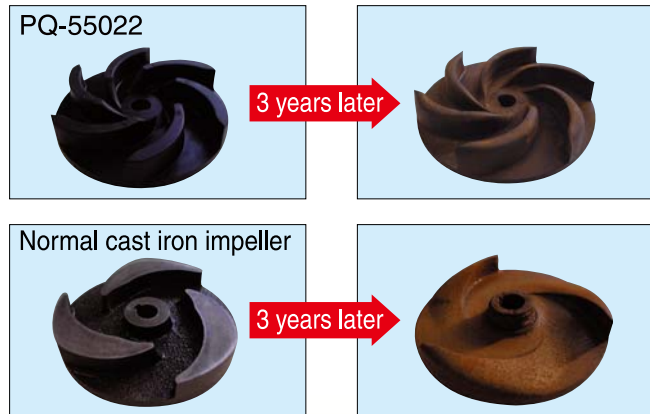

New



PQ-55022

■ Performance Curve

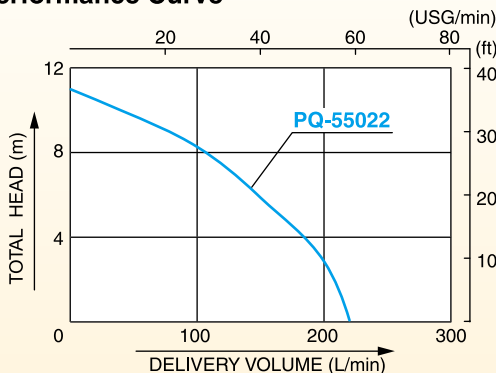

■ Specifications

Model		PQ-55022
PUMP	Connection Dia	50 mm (2")
	Total Head	11 m (36.1 ft)
	Delivery Volume	220 L/min (58 USG/min)
MOTOR	Voltage	AC 220 V
	Frequency	50 Hz
	Rated Current	2.7 A
	Output	400 W
	Consumption	550 W
	Revolution	2800 rpm
	Type	Induction Motor
	Power Cord	5 m (16.4 ft)
Standard Accessories		1 Hose Band, 1 Rope (5 m (16.4 ft))
Gross Weight		12.5 kg (27.5 lbs)
Dimensions L×W×H (mm)		245 × 205 × 410
Packing Unit		1

Light & Durable

- Double mechanical seals using silicon carbide ensure durability and shaft protection.
- Thermal protector cuts off circuit in case of overload during operation.



PS-55022



PSA-55022

**Automatic
Float Switch**

■ Specifications

	Model	PS-55022	PSA-55022
PUMP	Connection Dia	50 mm (2")	
	Total Head	10 m (32.8 ft)	
	Delivery Volume	280 L/min (74 USG/min)	
	Voltage	AC 220 V	
MOTOR	Frequency	50 Hz	
	Rated Current	3.6 A	
	Output	400 W	
	Consumption	600 W	
	Revolution	2600 rpm	
	Rating	Continuous	
	Type	Induction Motor	
	Power Cord	6 m (19.7 ft)	
Standard Accessories	1 Hose Nipple 1 Hose Band 1 Rope (5 m (16.4 ft))	1 Hose Band 1 Rope (5 m (16.4 ft))	
Gross Weight	58 kg (127.8 lbs)	65 kg (143.3 lbs)	
Dimensions L×W×H (mm)	460 × 460 × 442	495 × 495 × 505	
Packing Unit	4		

■ Performance Curve

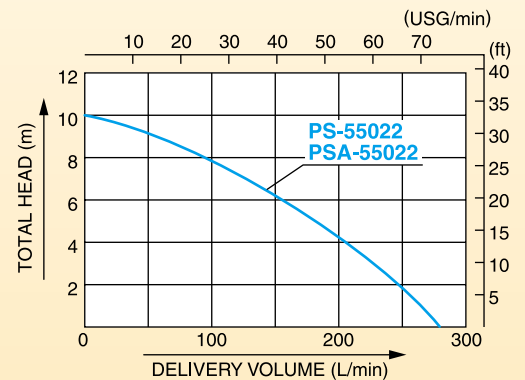

*Starting current is three times higher than rated current.

Triple Life Span Impeller Compared with Former Product

•Durable and long life time

Impeller is manufactured from a blended rubber compound providing maximum wear resistance up to three times over cast iron.

Maximal life-span and super hard mechanical seal.

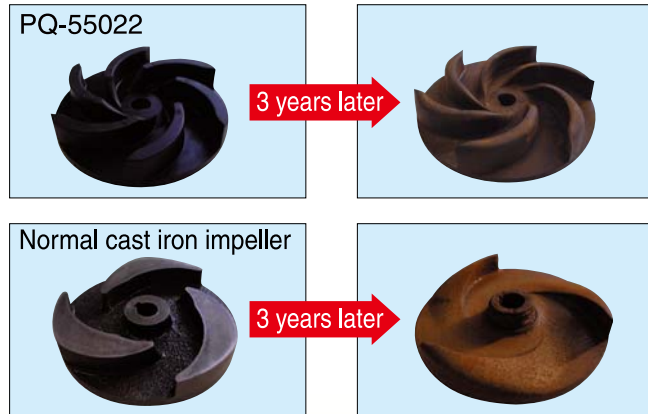

New



PQ-55022

■ Performance Curve

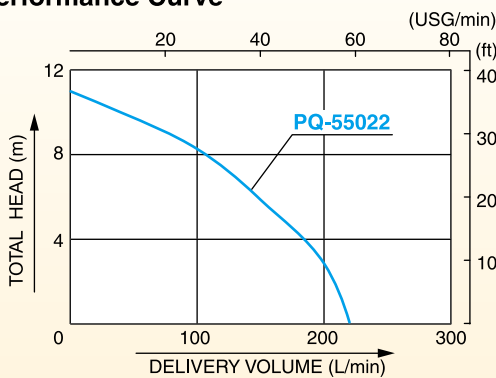

■ Specifications

Model		PQ-55022
PUMP	Connection Dia	50 mm (2")
	Total Head	11 m (36.1 ft)
	Delivery Volume	220 L/min (58 USG/min)
	Voltage	AC 220 V
MOTOR	Frequency	50 Hz
	Rated Current	2.7 A
	Output	400 W
	Consumption	550 W
	Revolution	2800 rpm
	Type	Induction Motor
	Power Cord	5 m (16.4 ft)
	Standard Accessories	1 Hose Band, 1 Rope (5 m (16.4 ft))
Gross Weight	12.5 kg (27.5 lbs)	
Dimensions LxWxH (mm)	245 × 205 × 410	
Packing Unit	1	

Light & Durable

- Double mechanical seals using silicon carbide ensure durability and shaft protection.
- Thermal protector cuts off circuit in case of overload during operation.



PS-55022



PSA-55022

**Automatic
Float Switch**

■ Specifications

Model		PS-55022	PSA-55022
PUMP	Connection Dia	50 mm (2")	
	Total Head	10 m (32.8 ft)	
	Delivery Volume	280 L/min (74 USG/min)	
	Voltage	AC 220 V	
	Frequency	50 Hz	
MOTOR	Rated Current	3.6 A	
	Output	400 W	
	Consumption	600 W	
	Revolution	2600 rpm	
	Rating	Continuous	
	Type	Induction Motor	
	Power Cord	6 m (19.7 ft)	
Standard Accessories	1 Hose Nipple 1 Hose Band 1 Rope (5 m (16.4 ft))	1 Hose Band 1 Rope (5 m (16.4 ft))	
Gross Weight	58 kg (127.8 lbs)	65 kg (143.3 lbs)	
Dimensions LxWxH (mm)	460 × 460 × 442	495 × 495 × 505	
Packing Unit	4		

■ Performance Curve

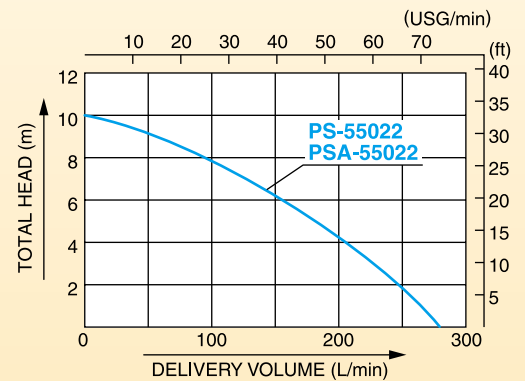

*Starting current is three times higher than rated current.

Great Durability for Muddy Water & Sea Water

Strong Durability

- Sic (Silicon Carbide) Mechanical Seal
- Big Size Bearings
- Oil chamber size is 6 times bigger than our current model, NSM

Easy Maintenance

- Easy to replace Condenser and Mechanical Seal
- Strainer can be removed without any tool



New



CP-59022

**Submersible pump for circulation
Continuous Use, 1 Year!**



Performance Curve

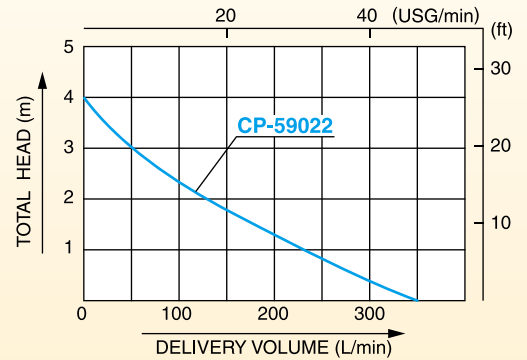

Specifications

Model		CP-59022
PUMP	Connection Dia	90 mm (3.5")
	Total Head	4 m (12.8 ft)
	Delivery Volume	350 L/min (21 m ³ /H)
	Voltage	AC 220 V
MOTOR	Frequency	50 Hz
	Rated Current	2.0 A
	Revolution	2500 rpm
	Type	Induction Motor
	Power Cord	5 m (16.0 ft)
Standard Accessory		1 Delivery Flange
Gross Weight		5.6 kg (12.3 lbs)
Dimensions LxWxH (mm)		220 × 220 × 585
Packing Unit		1

"PONDY" & "MARINE PET" Submersible Pump for Seawater

■ Applications

- Feeding or draining water in fish farms
- Washing purpose
- Draining bilge water



SK-2524



BL-2524N

■ Performance Curve

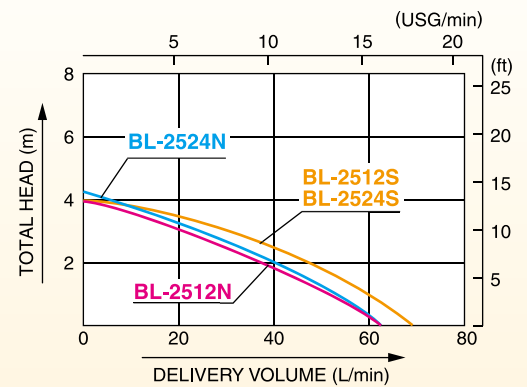
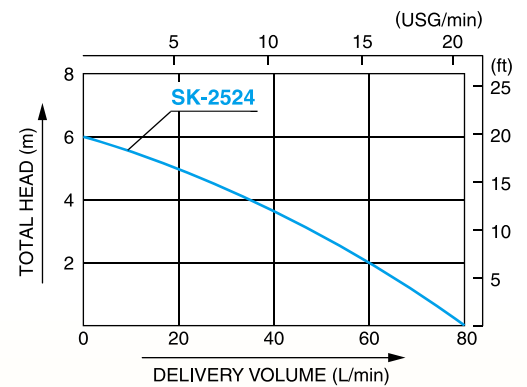

■ Specifications

Model		SK-2524	BL-2512S	BL-2524S	BL-2512N	BL-2524N
PUMP	Connection Dia	25 mm (1")				
	Total Head	6 m (19.6 ft)	4 m (13.1 ft)			4.2 m (13.8 ft)
	Delivery Volume	80 L/min (21 USG/min)	70 L/min (18 USG/min)		63 L/min (16 USG/min)	
MOTOR	Voltage	DC 24 V	DC 12 V	DC 24 V	DC 12 V	DC 24 V
	Frequency	—	—	—	—	—
	Rated Current	8.5 A	6.5 A	3.5 A	7.8 A	3.8 A
	Rating	Continuous				
	Output	123 W	45 W		50 W	
	Revolution	3200 rpm	5400 rpm		5800 rpm	
	Life Span	Approx. 500 hrs	Approx. 200 hrs		Approx. 500 hrs	
	Power Cord	5 m (16.4 ft)	2 m (6.5 ft)		2.95 m (9.7 ft)	
	Standard Accessories	1 Coupling Set (φ25) 1 Hose Nipple (φ20) 1 Hose Band (φ25) 1 Hose Band (φ20) 1 Rope (5 m (16.4 ft))	—			1 Elbow
Gross Weight	11 kg (24.2 lbs)	18.5 kg (40.7 lbs)		32 kg (70.5 lbs)		
Dimensions LxWxH (mm)	425 × 248 × 325	568 × 286 × 383		574 × 283 × 403		
Packing Unit	2			20		

FOR INDUSTRIAL APPLICATION

"GEAR PUMP" GL Series for Low Viscosity Oil

- Safety by-pass function protects pump.

Applications

- Kerosene
- Machine oil
- Heavy oil
- Light oil



GL-25-5

Performance Curve

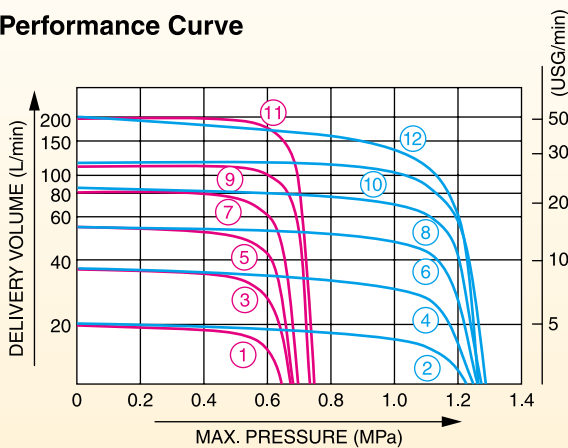

* Must not be used for gasoline.

Specifications

Model		GL-13-5	GL-13-10	GL-20-5	GL-20-10	GL-25-5	GL-25-10	GL-32-5	GL-32-10	GL-40-5	GL-40-10	GL-50-5	GL-50-10
Performance Curve No.		①	②	③	④	⑤	⑥	⑦	⑧	⑨	⑩	⑪	⑫
Connection Dia		13 mm (1/2")		20 mm (3/4")		25 mm (1")		32 mm (1 1/4")		40 mm (1 1/2")		50 mm (2")	
Power		0.4 kW	0.75 kW	0.75 kW	1.5 kW	1.5 kW	2.2 kW	2.2 kW	3.7 kW	2.2 kW	5.5 kW	3.7 kW	7.5 kW
Poles		4 P						6 P					
Max. Pressure		0.5 MPa (5 kgf/cm ²)	1 MPa (10 kgf/cm ²)	0.5 MPa (5 kgf/cm ²)	1 MPa (10 kgf/cm ²)	0.5 MPa (5 kgf/cm ²)	1 MPa (10 kgf/cm ²)	0.5 MPa (5 kgf/cm ²)	1 MPa (10 kgf/cm ²)	0.5 MPa (5 kgf/cm ²)	1 MPa (10 kgf/cm ²)	0.5 MPa (5 kgf/cm ²)	1 MPa (10 kgf/cm ²)
PUMP	Delivery Volume	20 L/min (5 USG/min)		35 L/min (9 USG/min)		55 L/min (14 USG/min)		85 L/min (22 USG/min)		123 L/min (32 USG/min)		200 L/min (52 USG/min)	
	Volume	17 L/min (4 USG/min)		29 L/min (7 USG/min)		46 L/min (12 USG/min)		71 L/min (18 USG/min)		100 L/min (26 USG/min)		165 L/min (43 USG/min)	
Coupling		ZDC						JIS					
Pump Shaft Dia		φ 18 mm						φ 22 mm					
Gross Weight		6 kg (13.2 lbs)	7 kg (15.4 lbs)	7 kg (15.4 lbs)	8 kg (17.6 lbs)	8 kg (17.6 lbs)	12 kg (26.4 lbs)	12 kg (26.4 lbs)	23 kg (50.7 lbs)	23 kg (50.7 lbs)	26 kg (57.3 lbs)	26 kg (57.3 lbs)	
Dimensions LxWxX (mm)		234 × 160 × 170		234 × 160 × 170		234 × 160 × 170		317 × 160 × 170		328 × 268 × 235		328 × 268 × 235	
Packing Unit		1											

"CHANGE MASTER" Oil Change Pumps

- Powerful pump transfers high viscosity oil. (Up to 800 cst)
- Highly recommended for motor oil change.
- Safety by-pass valve protects pump.

Applications

- Motor oil
- Machine oil
- Heavy oil
- Light oil



*Must not be used for gasoline.

Specifications

Model		GM-2524H
PUMP	Dia of Hose Inlet	25 mm (1")
	Dia of Hose Outlet	20 mm (3/4")
	Connection Thread	Inner Pipe Thread
	Max. Delivery Pressure	0.2 MPa (2 kgf/cm ²)
	Delivery Volume	20 L/min (5 USG/min)
	Applicable Viscosity	800 cst
MOTOR	Voltage	DC 24 V
	Rated Current	16 A
	Output	200 W
	Revolution	6200 rpm
	Rating	25 min
	Power Cord	5 m (16 ft)
Gross Weight	10 kg (22.1 lbs)	
Dimensions LxWxH (mm)	320 x 188 x 268	
Packing Unit	1	



GM-2524H

E-type Hose Set for GM Pumps

- Suction Dia: 25 mm (1") x 2 m (6.5 ft)
- Delivery Dia: 20 mm (3/4") x 2 m (6.5 ft)
- 1 Nozzle, 1 Strainer, 2 Joints



Performance Curve

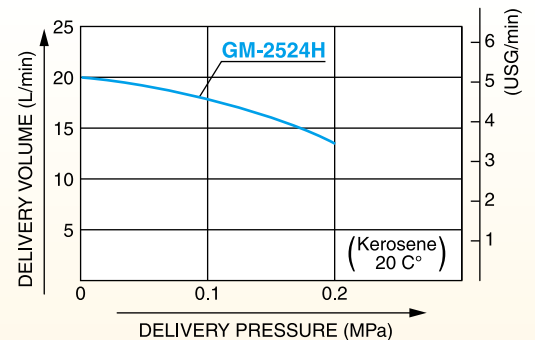

"FS PUMP" Self-priming Pump for Low Viscosity Oil



* Must not be used for gasoline.

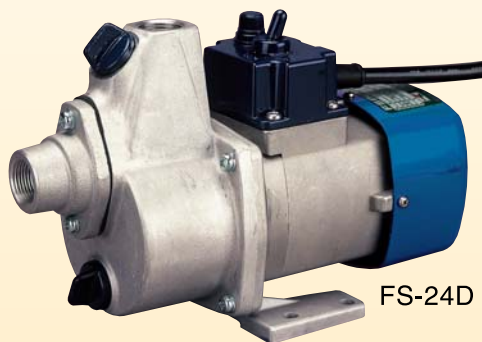

FS-24D

Specifications

Model	FS-12D	FS-24D
Connection Dia	20 mm (3/4")	
Total Head	7 m (23 ft)	9 m (30 ft)
Delivery Volume	40 L/min (10 USG/min)	50 L/min (13 USG/min)
Voltage	DC 12 V	DC 24 V
Rated Current	15 A	8 A
Output	80 W	90 W
Revolution	7300 rpm	
Gross Weight	20 kg (44.1 lbs)	
Dimensions LxWxH (mm)	790 x 315 x 240	
Packing Unit	5	

T-type Hose Set for FS Pumps

- Suction Dia: 20 mm (3/4") x 2 m (6.5 ft)
- Delivery Dia: 20 mm (3/4") x 2 m (6.5 ft)
- 1 Nozzle, 1 Strainer, 2 Joints



Performance Curve

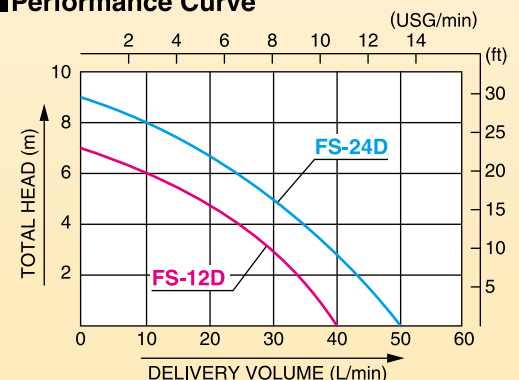

"GEAR PUMPS"

Suitable for Water, Oil & Various Liquids Applications



GB-13
GC-13



GB-25
GC-25

Applications (GB)

- Water
- Sea water
- Weak acids
- Various chemicals
- Coal tar



Applications (GC)

- Kerosene
- Light oil
- Machine oil
- Heavy oil



Performance Curve

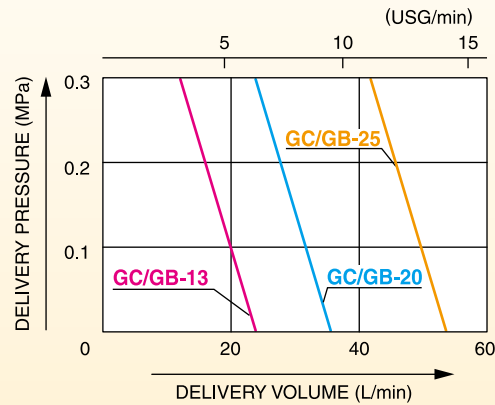

Specifications

Model	GC-13	GB-13	GC-20	GB-20	GC-25	GB-25
Gear Material	GC: Cast Iron / GB: Brass					
Connection Dia	13 mm (1/2")		20 mm (3/4")		25 mm (1")	
Delivery Volume	Revolution: 200 rpm	10 L/min (2 USG/min)	18 L/min (4 USG/min)		27 L/min (7 USG/min)	
	Revolution: 400 rpm	21 L/min (5 USG/min)	37 L/min (9 USG/min)		55 L/min (14 USG/min)	
	Revolution: 600 rpm	32 L/min (8 USG/min)	56 L/min (14 USG/min)		83 L/min (22 USG/min)	
Delivery Pressure	0.1 – 0.3 MPa (1 – 3 kg/cm ²)					
Syphoning Factor	3 m (10 ft)					
Power	200 W		400 W		750 W	
Pulley	125 × A1		150 × A1		200 × A1	
Gross Weight	17.5 kg (38.6 lbs)		25 kg (55.1 lbs)		22.5 kg (49.6 lbs)	
Dimensions LxWxH (mm)	316 × 283 × 211		492 × 262 × 194		397 × 277 × 265	
Packing Unit	4				2	

Powerful "FILL PUMP" Only 2 Minutes to Empty 200 L Drum (FR-200)

- Two stage system of axial flow vane and spiral vane result in an excellent flow rate.

■ Applications

- Low Viscosity oil
- Heavy fuel oil A
- Kerosene
- Diesel



■ Performance Curve

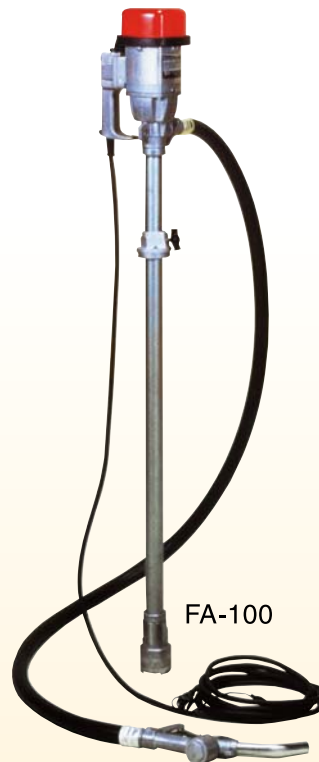
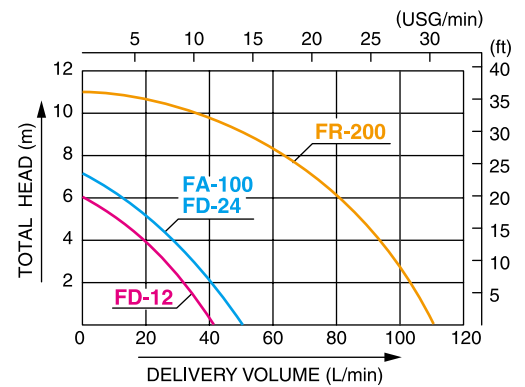

★ These pumps are not designed for use with liquids with low flash-point, such as gasoline, etc.

■ Specifications

Model		FD-12	FD-24	FA-100		FR-200	
PUMP	Connection Dia	20 mm (3/4")				32 mm (1 1/4")	
	Connection Thread	Inner Pipe Thread					
	Total Head	6 m (19 ft)	7 m (23 ft)		11 m (36 ft)		
PUMP	Delivery Volume	40 L/min (10 USG/min) (Kerosene, Light Oil)	50 L/min (13 USG/min) (Kerosene, Light Oil)		110 L/min (29 USG/min) (Kerosene, Diesel)		
	Type	Enclosed Fan-Cooled Commutator				Fan-Cooled Commutator	
MOTOR	Voltage	DC 12 V	DC 24 V	AC 110 V / 130 V	AC 220 V - 240 V	AC 110 V	AC 220 V - 240 V
	Rated Current	14 A	7 A	2 A	1 A	5 A	2.5 A
	Output	80 W	90 W	100 W		200 W	
	Revolution	7000 rpm	7300 rpm	7500 rpm		6200 rpm	
	Rating	Continuous					
	Power cord	Oil-Proof Cord 5 m (16.4 ft)					
Delivery Hose		1 Oil-Proof Rubber Hose (20 mm (3/4") x 2 m)					
Gross Weight		20 kg (44.1 lbs)				30 kg (66.1 lbs)	
Dimensions LxWxH (mm)		1228 x 291 x 172				1290 x 490 x 205	
Packing Unit		2					

Suitable for Transferring Kerosene & Diesel

- 10 minutes to empty 200 L drum.
- Easy to use gun nozzle.
- Suction pipe with mesh strainer.

■ Applications

- Kerosene
- Diesel



■ Specifications

Model	FP-25	FP-2512
Connection Dia	25 mm (1")	
Total Head	3.5 m (11 ft)	2.8 m (9 ft)
Delivery Volume	20 L/min (5.3 USG/min)	18 L/min (4.7 USG/min)
Voltage	AC 100 V AC 220 V	DC 12 V
Frequency	50 Hz / 60 Hz	
Power Code	4 m (13 ft)	
Delivery Hose	1.5 m (4.9 ft)	
Gross Weight	3.8 kg (8.3 lbs)	3.1 kg (6.8 lbs)
Dimensions LxWxH (mm)	1190 × 235 × 130	
Packing Unit	1	



FP-25

For High Viscosity Oil (Up to 2000 cst)

- Specially designed for dispensing oil at service stations.

■ Applications

- High viscosity oil



SO-25

■ Specifications

Model	SO-25
Delivery Volume	0.5 L/Stroke (0.1 USG/Stroke)
Pump Length	1380 mm (54")
Suction Pipe Dia	32 × 1038 (1¼" × 40")
Gross Weight	55 kg (121.2 lbs)
Dimensions LxWxH (mm)	1080 × 398 × 220
Packing Unit	5

"HIGH LITER PUMP" High Volume

- Delivers 1 L per rotation.
- Mesh strainer can filter fine dust.
- Applicable for low viscosity oil.

■ Applications

- Diesel
 - Kerosene,
 - Heavy fuel oil A
- *Oil temperature is over 10°C



LP-32

■ Specifications

Model	LP-32
Delivery Volume	1 L / 1 Rotation, (Normal Use) 100 L/min (26 USG/min)
Suction Pipe	32 × 956 (1¼" × 37")
Delivery Hose (mm)	32 × 1280 (1¼" × 50")
Strainer	#60 with Mesh, Polyethylene
Gross Weight	38 kg (83.7 lbs)
Dimensions LxWxH (mm)	1137 × 252 × 295
Packing Unit	5

"HAND ROTARY PUMP"

Compact in Design & Light Weight

- Applicable for low viscosity.

■ Applications

- Heavy fuel oil A
- Kerosene
- Diesel



*Oil temperature is over 10°C

■ Specifications

Model	SB-20	SB-25
Delivery Volume	20 L (5 USG) / 105 Rotations	20 L (5 USG) / 72 Rotations
Impeller Material	PPS	
Delivery Hose (mm)	20 × 1100 (¾" × 43")	25 × 1280 (1" × 50")
Gross Weight	24 kg (52.9 lbs)	25 kg (55.1 lbs)
Dimensions LxWxH (mm)	1065 × 245 × 145	1085 × 202 × 225
Packing Unit	6	4



SB-25

"BIG AUTO PUMP"

Light weight & Economical to Use

- Made from strong plastics.

■ Applications

(PP-25)

- Dispensing small volumes of liquid
- Heavy fuel oil A
- Kerosene
- Diesel
- Water
- Wine

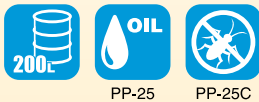

(PP-25C)

- Solvent



PP-25

PP-25C

■ Specifications

Model	PP-25	PP-25C
Delivery Volume	20 L/min (5 USG/min)	
Material	Polyethylene	
Pump Length	1190 mm (47")	
Suction Pipe (mm)	(Inside Dia) 22 × 875 (0.86" × 34")	
Delivery Hose (mm)	(Inside Dia) 20 × 1180 (¾" × 46")	
Gross Weight	11 kg (24.2 lbs)	
Dimensions LxWxH (mm)	1237 × 460 × 270	
Packing Unit	20	

■ PP-25C Chemical Compatibility Rating Information

Rating Scale	
○	No Effect
△	Moderate Effect
×	Not Recommended
N	Information Not Available

Chemical (100% concentration unless noted)	Rating
A Acetone	×
Ammonium Hydroxide	N
C Chlorine	○
D Deionized Water	△
Diesel Fuel	○
E Ethanol	○
G Gasoline	△
Glycol	N
H Hydrochloric Acid (20%)	○
Hydrochloric Acid (37%)	○
Hydrochloric Acid (100%)	○
I Isopropyl Alcohol	N
K Kerosene	○
L Lacquer Thinner	×
M Methanol	○
Methyl Chloride	×
Methyl Ethyl Ketone	×
Mineral Spirits	N
Motor Oil	○
N Nitric Acid (20%)	△
Nitric Acid (50%)	△
Nitric Acid (Concentrated)	△
O Oil, Hydraulic	○
P Paint	×
Phosphoric Acid (< 40%)	○
Phosphoric Acid (≥ 40%)	○
S Salt Water	○
Seawater	○
Sodium Hypochlorite	N
Sodium Hydroxide (20%)	N
Sodium Hydroxide (50%)	N
Sodium Hydroxide (80%)	N
Sulfuric Acid (<10%)	○
Sulfuric Acid (10-75%)	○
Sulfuric Acid (75-100%)	○
W Water	○
X Xylene	△

"PACO-PET" Plastic Syphon Pumps

■ Applications

- Kerosene
- Gasoline
- Diesel oil
- Solvent
- Water (Non-potable)

■ Specifications

Model	PH-10	PH-20
Delivery Volume	6.7 L/min (1 USG/min)	11.5 L/min (3 USG/min)
Pump Length	690 mm (27")	840 mm (33")
Gross Weight	11.5 kg (25.3 lbs)	10.5 kg (23.1 lbs)
Dimensions LxWxH (mm)	690 × 340 × 618	810 × 355 × 510
Packing Unit	120	60

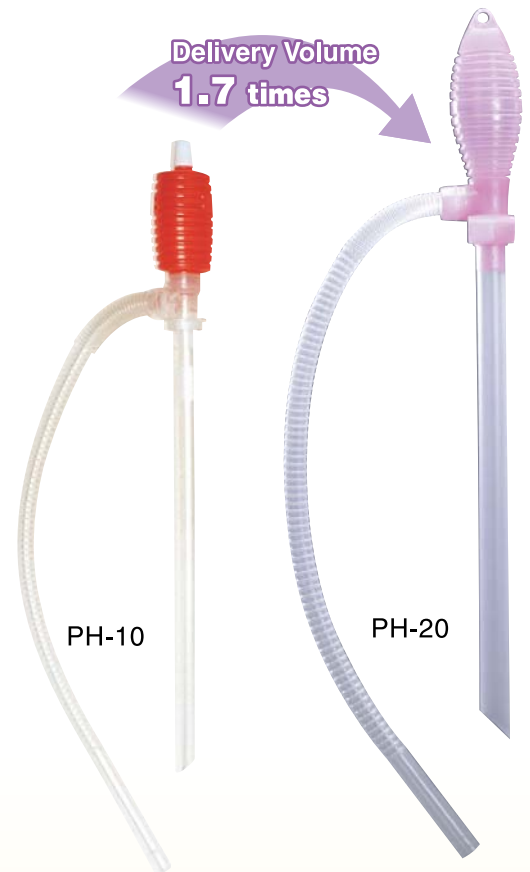

"MAMA AUTO" Plastic Pumps Operated by Dry Cell Battery

■ Applications

- Kerosene

No
Overflow
Trouble

(EP-303,
EP-303BC)

Big Switch
for Easy
ON/OFF
Control

Type AA

2 Batteries
(Not Included)

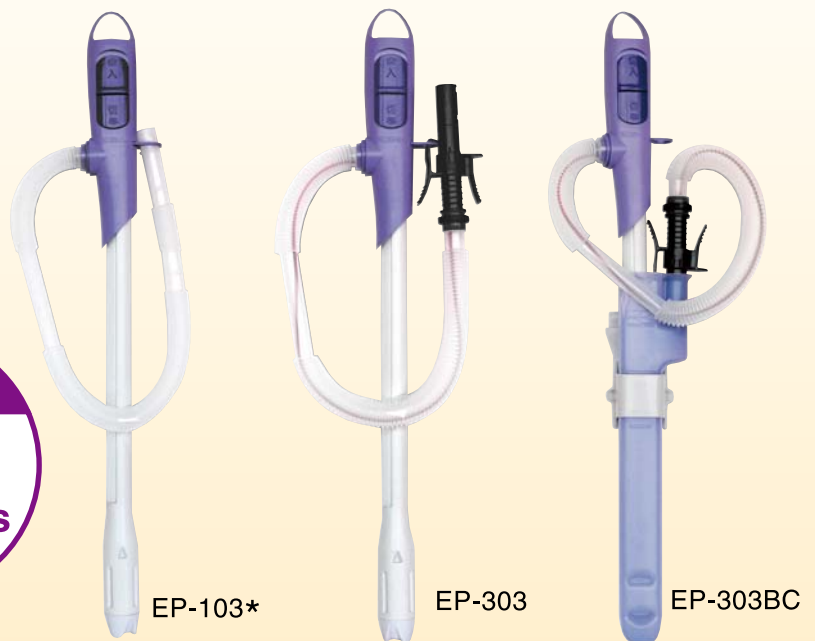

■ Specifications

Model	EP-103	EP-303	EP-303BC
Applications	Kerosene		
Delivery Volume	10 L/min (2 USG/min)		
Pump Length	547 mm (21")		
Case Length	—	—	435 mm (17")
Power	2 × 1.5 V AA Batteries (Not Included)		
Gross Weight	2.2 kg (4.8 lbs)	7 kg (15.4 lbs)	6 kg (13.2 lbs)
Dimensions LxWxH (mm)	310 × 305 × 600		290 × 300 × 630
Packing Unit	20		12

*EP-103 does not have auto stop function.



GARDEN SPRAYERS

"Double Piston Method"

- "One hand operation lever"
Easy operation designed for spraying continuously or intermittently.
- 2-stage extendable nozzle
630 – 1135 mm.
- Safety valve with simple pressure gauge.
- Big funnel for easy pouring.



Double Piston Method

Thick piston

Powerful!

Thin piston

Light!

Switchable Nozzle

1 Head

2 Heads



HS-503W

HS-707W

HS-401E

■ Specifications

Model	HS-503W	HS-707W	HS-401E
Tank Capacity	5 L	7 L	4 L
Hose Length	5 m (16 ft)		2 m (6.5 ft)
Nozzle Type	2-Stage Extendable 2-Head	4-Stage Extendable 2-Head	1-Head Nozzle
Total Extendable Length	63–113.5cm (24"–44")	63–201cm (24"–79")	38 cm (15")
Operating Pressure Around Safety Valve	0.4 MPa (4 kgf/cm ²)		0.2MPa(2kgf/cm ²)
Spray Area	56 – 72.7 m ²	79 – 99 m ²	46 – 59 m ²
Gross Weight	14 kg (30.8 lbs)	15 kg (33.1 lbs)	11.1 kg (11.1 lbs)
Dimensions LxWxH (mm)	420 × 420 × 665		830 × 425 × 425
Packing Unit	4		8

"Garden Master" Powered by Dry Cell Battery

- Big tank opening for easy cleaning and refilling.
- Internally sloped bottom design ensures all liquids are used up.



GT-3



GT-3H

Specifications

Model	GT-2	GT-3	GT-5	GT-3H	GT-5H
Tank Capacity	2 L	3 L	5 L	3 L	5 L
Hose Length	1 m (3.3 ft)	1.5 m (5 ft)		1.7 m (5.6 ft)	
Nozzle Type	1-Stage, 1-Head	3-Stage Extendable, 1-Head		3-Stage Extendable, 1-Head	1-Stage 1-Head, + Extensional
Total Extendable Length	42 cm (16")	43 – 100 cm (16" – 39")		37 – 96 cm (14" – 38")	59 – 96 cm (23" – 38")
Battery	DC 1.5 V × 4 pcs			DC 1.5 V × 6 pcs	
Rating Voltage	4.8 V			7.2 V	
Battery Life	Approx. 20 L (5.3 USG) (Alkaline Battery)	Approx. 70 L (18 USG) (Alkaline Battery) Approx. 30 L (8 USG) (Manganese Battery)		1 Head: Approx. 80 L (21 USG) (Alkaline Battery) 2 Head: Approx. 80 L (21 USG) (Alkaline Battery)	
Spray Volume	Approx. 240 ml/min (Shower Spray) Approx. 400 ml/min (Sharp Spray)	Approx. 240 ml/min (Shower Spray) Approx. 400 ml/min (Sharp Spray)		1 Head: 450 ml/min (Shower Spray), 570 ml/min (Sharp Spray) 2 Head: 680 ml/min (Shower Spray), 740 ml/min (Sharp Spray)	
Shower Spraying Time (Full Tank)	9 min	13 min	21 min	1 Head: 8 min, 2 Head: 5 min 1 Head: 13 min, 2 Head: 8 min	
Spray Angle	60 °				
Jet Distance	4 m (13 ft)			1 Head: 6.5 m, 2 Head: 4.5 m	
Standard Accessories	Measurement Cup	1 Spout			
Gross Weight	3.8 kg (8.4 lbs)	8 kg (17.6 lbs)	4.5 kg (9.9 lbs)	5.1 kg (11.2 lbs)	4.4 kg (9.7 lbs)
Dimensions LxWxH (mm)	330 × 330 × 375	390 × 540 × 385	280 × 390 × 385	405 × 385 × 355	405 × 385 × 310
Packing Unit	4			2	

"GROUND MASTER" Backpack Manual Sprayer

Specifications

Model	RV-10DX	RV-15DX
Tank Capacity	10 L	15 L
Pump	Diaphragm Pump	
Max. Pressure	0.5 MPa (5 kgf/cm ²)	
Nozzle Length	60 cm (23")	
Spray Volume [Common Pressure 0.3 MPa (3 kgf/cm ²)]	Bubble Type Herbicide Nozzle : 600 mL/min 2-Head Nozzle (Shower Spray) : 900 mL/min (Sharp Spray) : 1300 mL/min	
Spray Pressure	0.5 MPa (5 kgf/cm ²)	
Connection	G ¹ / ₄ (PF ¹ / ₄)	
Standard Accessories	1 Bubble Type Herbicide Nozzle with Cover, 1 2-Head Nozzle, 1 Measuring Cup, 1 Nozzle Grip, 1 Nozzle Pipe	
Net Weight	6.0 kg (13 lbs)	6.6 kg (14.5 lbs)
Dimensions LxWxH (mm)	475 × 235 × 675	475 × 285 × 675
Packing Unit	2	



RV-10DX

Compact, Light Weight, Long-Lasting

• **Enable to Recharge at any time**

Lithium-ion battery does not cause a memory effect, Rechargeable any time without lowering battery life expectancy.



New



**Lithium-ion
battery**



LS-10

Standard Accessories



Bubble Type Herbicide Nozzle with Cover



2-Head Nozzle



Bubble Type Herbicide Nozzle



Measuring Cup



LS-15

■ **Specifications**

Model	LS-10	LS-15
Tank Capacity	10 L	15 L
Pump	Diaphragm Pump	
Max. Pressure	0.3 MPa (3 kgf/cm ²)	
Spray Volume	0.67 L/min (0.18 USG/min) [Spray Pressure: 0.26 MPa (2.6 kgf/cm ²)]	
	0.5 L/min (0.13 USG/min) [Spray Pressure: 0.28 MPa (2.8 kgf/cm ²)]	
Battery	Lithium-ion Battery, 14.4 V, 2.2 Ah	
Battery Charger	Hi-Charging AC 100 V – 240 V, 50 / 60 Hz	
Recharging time for Battery	Approx. 1.5 hrs (per 1 Battery)	
Operating Time	Approx. 2.5 hrs	Approx. 5 hrs (for 2 Batteries)
Connection	G ¹ / ₄	
Standard Accessories	1 Quick Battery Charger, 1 Bubble Type Herbicide Nozzle with Cover, 1 Bubble Type Herbicide Nozzle, 1 2-Head Nozzle, 1 Measuring Cup, 1 Syringe, 1 Nozzle (60cm)	
Gross Weight	5.8 kg (12.8 lbs)	6.4 kg (14.1 lbs)
Dimensions LxWxH (mm)	390 × 247 × 575	390 × 247 × 640
Packing Unit	1	

Double Function for Disinfection and Herbicide



- High pressure piston pump performs
Max. pressure 3.0 MPa (30 kgf/cm²)



New



ES-10DX



ES-15DX

Two kinds of nozzles are included.



Bubble Type Herbicide Nozzle with Cover



2-Head Nozzle

■ Specification

Model		ES-10DX	ES-15DX
PUMP	Tank Capacity	10 L	15 L
	Type	Single Differential Piston Pump	
	Max. Pressure	3.0 MPa (30 kgf/cm ²)	
ENGINE	Max. Suction Volume	5.2 L/min (1.37 USG/min)	
	Type	Forced Air-cooled 2-stroke Gasoline Engine	
	Model	Koshin K25	
	Total Exhaust Volume	25.4 cc	
	Continuous Operation Time	Approx. 50 min	
	Delivery Hose	φ6 mm × 1.3 m (4.2 ft)	
	Adjustment Of Pressure	6 Levels Changeable	
Nozzle		Vertical 2 head Nozzle	
		Bubble Type Herbicide Nozzle Herbicide Nozzle with Cover	
Accessories	1 Measurement Cup, 1 Ball Cock, 1 Grip, 1 Nozzle Pipe (60 cm), 1 Connector, 1 2-Head Nozzle, 1 Bubble Type Herbicide Nozzle with Cover		
Gross Weight	10.5 kg (23.1 lbs)		
Dimensions LxWxH (mm)	400 × 440 × 575	390 × 430 × 560	
Packing Unit	1		

Fine Mist Sprayer with Tank

- Convenient hose reel attached.



MS-ER50
MS-ER100

φ 6×100m Hose



MS-ER100

5 Level Spraying Pressure

φ 8.5×20m Hose
25L Tank

φ 6×50m Hose

50L Tank



MS-E2R25TH85



MS-ER50
+ TK-50N



TK-50N

Convenient
Caster for
Mobility



Easy & Tidy Hose Coiling



Specifications

Model (Hose Dia)	MS-E2R25TH85 (φ 8.5 mm)	MS-ER50 (φ 6 mm)	MS-ER100 (φ 6 mm)	TK-50N	
PUMP	Type	Double Piston Pump			
	Max. Suction Head	8.6 L/min (2 USG/min)			
	Delivery Volume	1.2 – 5.4 L/min	1.0 – 2.9 L/min	1.0 – 2.4 L/min	
	Max. Pressure	3.0 MPa (30 kgf/cm ²)			
	Nozzle Head	Spray / Straight Shower Nozzle Adjustable Granular Type 2-Head Nozzle, Bubble Type 2-Head Nozzle Vertical	Granular Type 2-Head Nozzle Bubble Type 2-Head Nozzle Vertical		Length: 1048 mm (41")
Delivery Hose	φ 8.5 × 20 m (66 ft)	φ 6 × 50 m (164 ft) (With Reel)	φ 6 × 100 m (328 ft) (With Reel)	Width: 575 mm (22")	
ENGINE	Type	Forced Air-cooled 2-stroke Gasoline Engine	Forced Air-cooled 4-stroke Gasoline Engine		Height: 846 mm (33")
	Model	EC025	EH025		
	Exhaust Volume	24.5 cc			
	Rated Output	0.55 kW (0.7 PS) / 6000 rpm	0.55 kW (0.7 PS) / 7000 rpm		Tank: 50 L (30 USG)
	Max. Output	0.88 kW (1.2 PS) / 7000 rpm	0.81 kW (1.1 PS) / 7000 rpm		
	Fuel	2 Stroke Mixed Gas and Oil (25:1)	Automotive Unleaded Gasoline		
	Fuel Tank Capacity	0.6 L (0.16 USG)	0.5 L (0.45 USG)		
	Continuous Operating Time	Approx. 40 min			
	Starting Method	Recoil Starter			
	Gross Weight	25.5 kg (56.2 lbs)	25 kg (55.1 lbs)	28.5 kg (62.8 lbs)	23.5 kg (50.7 lbs)
Dimensions LxWxH (mm)	705 × 490 × 645	710 × 470 × 450		875 × 590 × 595	
Packing Unit	1				

FOR FISHERY INDUSTRY

Light weight & Compact Most Suitable for Fishing Boats

Applications

- Winding anchor for boats
- Drawing fishing net
- Towing line
- Winding up basket



REL-2512



RES-2512

REL-2524 (250 W, 24 V Type)

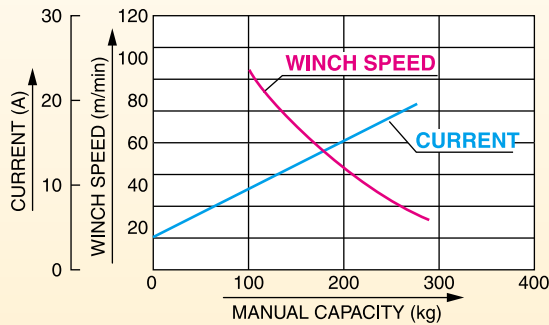

Performance Curve

RES-2512, REL-2512 (250 W, 12 V Type)

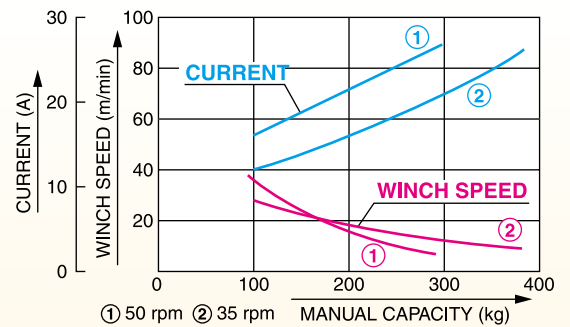

RES-4024, REL/RES-4024 (400 W, 24 V Type)

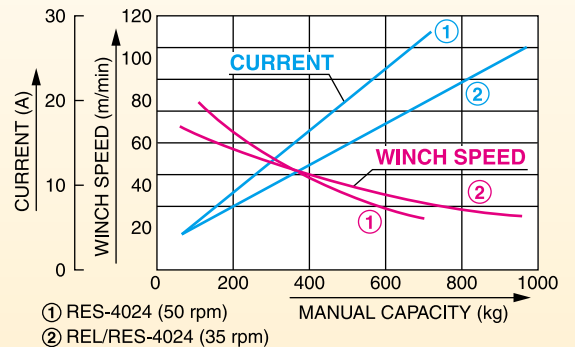

Specifications

Model	RES-2512	REL-2512	REL-2524	RES-4024	REL-4024	RES-4024L	REL-4024L
Voltage	DC 12 V			DC 24 V			
Rated Current	30 A		30 A	25 A			
Motor Output	250 W			400 W			
Rating	1 h / 30 A		1 h / 30 A	1 h / 25 A			
Roller Revolution	50 rpm (Low), 100 rpm (High)		50 rpm (Low), 100 rpm (High)	50 rpm (Low), 100 rpm (High)		35 rpm (Low), 70 rpm (High)	
Manual Capacity	Max. 280 kg (Low), 140 kg (High), (90 A)	280 kg (Low), 140 kg (High)	280 kg (Low), 140 kg (High)	700 kg (Low), 350 kg (High)	900 kg (Low), 450 kg (High)		
Rating	90 kg (Low), 45 kg (High), (30 A)	140 kg (15 A)	140 kg (15 A)	140 kg (Low), 70 kg (High), (25 A)	200 kg (Low), 100 kg (High), (25 A)		
Winch Speed (With 100 kg Load)	6 m/min (19 ft/min) (Low) 13 m/min (42 ft/min) (High)	23 m/min (75 ft/min)	23 m/min (75 ft/min)	20 m/min (65 ft/min) (Low) 33 m/min (108 ft/min) (High)	13 m/min (49 ft/min) (Low) 23 m/min (82 ft/min) (High)		
Standard Accessories	1 Cable Gland for Ship, 1 Waterproofing Plate, 1 Vertical Type Main Body Packing, 5 Crimping Terminals, 1 Connection Terminal						
Gross Weight	20 kg (44 lbs)	15 kg (33 lbs)	14.5 kg (32 lbs)	24 kg (53 lbs)	20.5 kg (45 lbs)	24 kg (53 lbs)	20.5 kg (45 lbs)
Dimensions L×W×H (mm)	570×250×285	478×245×285	478×245×285	560×240×270	478×245×285	560×240×270	478×245×285
Packing Unit	1						

High Speed & High Load Rolling Up Max. Winch Up Power 900 kg

- Use magnet motor. Simple wiring and easy to switch direction between clockwise to counterclockwise.
- Approx. 25 % more power from usual 400 W type by high speed and high load rolling up.
- 2 stage switchable winch capacity (REL, RES).
Switch to 900 kg / 50 rpm and 450 kg / 100 rpm by gearshift.
- Motor case, Roller, etc are made of aluminum alloy.
Light, compact, sea water proof and no rust damage to FRP boat.
- Polyurethane coat protects corrosion perfectly.



Performance Curve

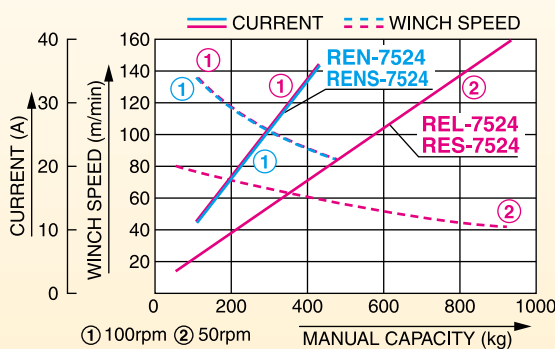

Specifications

Model	REN-7524	RENS-7524	REL-7524	RES-7524
Voltage	DC 24 V			
Rated Current	43 A			
Motor Output	750 W			
Rating	1 h / 43 A			
Roller Revolution	100 rpm		50 rpm (Low), 100 rpm (High)	
Manual Capacity	450 kg (150 A)		900 kg (Low), 450 kg (High), (150 A)	
Capacity Rating	110 kg (43 A)		220 kg (Low), 110 kg (High), (43 A)	
Winch Speed	33 m/min (108 ft/min)		17 m/min (55 ft/min) (Low), 33 m/min (108 ft/min) (High)	
Standard Accessories (RES, REN Type Only)	1 Cable Gland For Ship, 1 Waterproofing Plate, 1 Vertical Type Main Body Packing, 2 Crimping Terminals			
Gross Weight	25 kg (55 lbs)	35 kg (77 lbs)	24 kg (53 lbs)	29 kg (64 lbs)
Dimensions L×W×H (mm)	510 × 280 × 290	585 × 315 × 330	520 × 280 × 270	570 × 275 × 285
Packing Unit	1			

Effective Electromagnetic Brake Model

- Motor case is made of corrosion resistance aluminum alloy to withstand seawater.
- Possible to stop instantly.

Applications

- Winding anchor for boats
- Drawing fishing net
- Towing line
- Winding up basket



REL-5524LB



RES-5524LB

Specifications

Model		RES-5524LB	REL-5524LB
Voltage		DC 24 V	
Rated Current		31 A	
Motor Output		550 W	
Rating		1 h / 31 A	
Roller Revolution		35 rpm (Low), 70 rpm (High)	
Manual Capacity	Max.	1000 kg (Low), 500 kg (High)	
	Rating	280 kg (Low), 140 kg (High)	
Winch Speed (With 100 kg Load)		13 m/min (42.6 ft/min) (Low) 23 m/min (75.5 ft/min) (High)	
Electromagnetic Brake	Static Friction Torque	4 N·m (0.4 kgf·m)	
	Rated Voltage	DC 24 V	
	Rated Capacity	15 W	
Standard Accessories		1 Waterproofing Plate, 1 Vertical Type Main Body Packing, 5 Machine Screws M5x20	
Gross Weight		30 kg (66 lbs)	
Dimensions LxWxH (mm)		593 x 330 x 355	
Packing Unit		1	

Performance Curve

- RES-5524LB, REL-5524LB (550 W, 24 V Type)

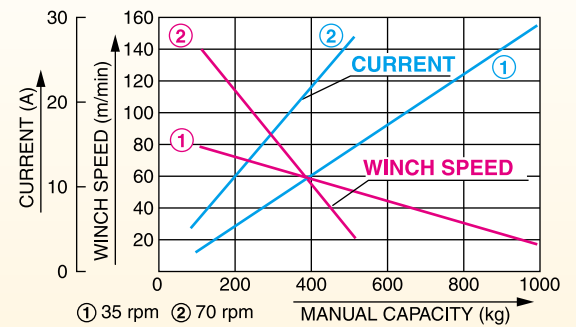

ECARL BOX

Just Changing Box Makes Your ECARL New

Example:
REL+REF



RES-330A
Suitable model:
• All REL model



RES-330B with 3-button switch
Suitable model:
• All REL model



REF-300
Suitable model:
• REL-2512
• REL-2524
• REL-4024
• REL-4024L



REF-330
Suitable model:
• All REL model



3-button switch
Suitable model:
• RES-330B
• Attached to REF-330

"NEW BILGE KING" Necessities for Boat

- Auto-stop feature prevents dry running, increases pump performance and life.
- Easy to use starter switch. Integrated fuse and switch assembly for ease of maintenance. Separate switch can be attached anywhere you want.
- Strainer and switch are made of a special sea water and oil resistance resin for longer durability.
- Two stage system of axial flow vane and spiral vane
- Easy to clean strainer.

■ Applications

- Draining of water and oil/water mix from bilge



BK-12



Standard Accessories

Type S Pump for without Accessories For Replacement "BILGE PUMP"



BK-12S

How to Attach Pump

Attach pump at 45 degree angle to set suction mouth and delivery mouth face upper side with 4 screws ($\phi 5 \times 10$). (See the picture below)

In a dry place, attach pump to the side of boat about 50 to 70 cm away from the bottom of the boat.

Choose the location to set the pump by considering the length of battery and starting switch cable (3 m).

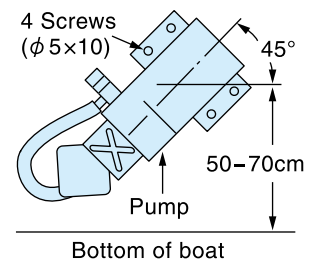

■ Specifications

Model	BK-12	BK-12S	BK-24	BK-24S
Suction / Delivery Dia	15 mm (1/2")			
Max. Delivery Volume	20 L/min (5 USG/min)			
Voltage	DC 12 V		DC 24 V	
Rated Current	10 A		5 A	
Suction Head	1 m (3 ft)			
Suction Time	2 - 5 sec (20 °C)			
Rating	80 W		90 W	
Standard Accessories (*Type S : Not Included)	1 Code with Starting Switch, 4 Tapping Screws (5x10), 4 Tapping Screws (4x16), 1 Fuse (15 A)	1 Strainer, 4 Tapping Screws (4x20), 1 Water Proofing Connector (Only S Type)	1 Delivery Nozzle, 4 Tapping Screws (4x10), 1 Fuse (8 A)	1 Delivery Nozzle Nat, 4 Tapping Screws (4x10), 1 Hose (3 m),
Gross Weight	18.5 kg (41 lbs)	11 kg (24 lbs)	18.5 kg (41 lbs)	11 kg (24 lbs)
Dimensions LxWxH (mm)	495 x 333 x 351	340 x 306 x 265	495 x 333 x 351	340 x 306 x 265
Packing Unit	4			

*BK-12S, BK24S is pump for replacement.

"REVOLVEX PUMPS" Flexible Rubber Impeller for Seawater



- Complete structure is manufactured from gunmetal, no rusting.
- START/STOP is easily controlled by pressing one switch. (MFC type)
- MFC type is fitted with electromagnetic clutch.
- Easy to replace rubber impeller.
- Self-priming.

■ Performance Curve

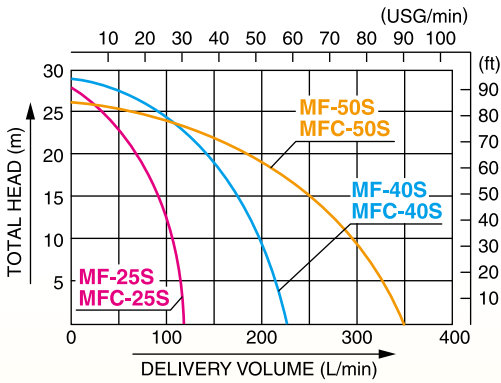

MF-25S

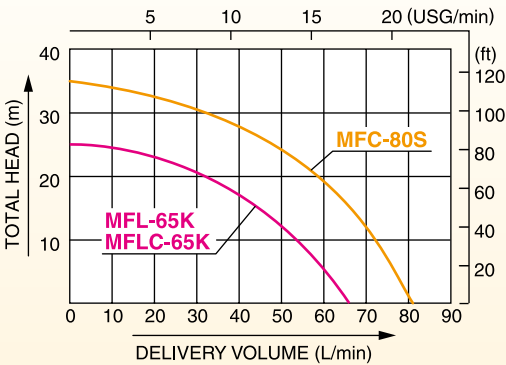

MFC-40S

For Seaweed Model Pumping Up Seaweed at Once, And Transferring it without Damage



- Adopted special impeller to avoid damage by seaweed.
- Special sleeve to transfer seaweed smoothly.

■ Applications

- Transfer seaweed from small boat to mother ship
- Built in for the machinery for seaweed
- Discharge of bilge water, emergency water discharge
- Washing a deck or hold

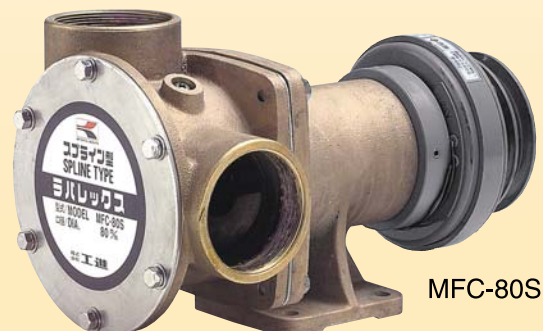

MFC-80S

Specifications

(*Products by order)

Model	MF-25S	MF-40S	MF-50S	MFC-80S*	MFLC-65K*	MFL-65K*
Connection Dia	25 mm (1")	40 mm (1½")	50 mm (2")	80 mm (3")	65 mm (2½")	
Connection Thread	Inner Pipe Thread					
Material	Bronze Castings (Gunmetal)					
Total Head	28 m (92 ft)	29 m (95 ft)	26 m (85 ft)	35 m (114 ft)	24 m (78 ft)	
Delivery Volume	115 L/min (30 USG/min)	215 L/min (56 USG/min)	350 L/min (92 USG/min)	820 L/min (216 USG/min)	650 L/min (171 USG/min)	
Output	1.5 kw (2.0 PS) / 1750 rpm		3.7 kw (5.0 PS) / 1750 rpm	7.5 kW (10.2 PS) / 1,750 rpm	5.5 kW (7.5 PS) / 1,750 rpm	
Number of Blades	9			13	6	
Driving Method	Belt Drive					
Revolution Direction	Anti-clockwise (Watching from Driving Shaft)					
Revolution	500 – 2300 rpm					
Shaft Dia	20 mm (¾")		25 mm (1")	Electromagnetic Clutch		25 mm (1")
Standard Accessory	Parallel Key					
Gross Weight	7.5 kg (16 lbs)	9.5 kg (21 lbs)	11.5 kg (25 lbs)	35 kg (77 lbs)	25 kg (55 lbs)	20 kg (44 lbs)
Dimensions LxWxH (mm)	262 × 150 × 190	275 × 168 × 183	352 × 172 × 229	430 × 240 × 280	460 × 234 × 285	460 × 234 × 285
Packing Unit	1					

Electromagnetic Clutch Specifications

*In case power is supplied by general purpose engine, choose MFC series (with clutch). (Need power source for clutch.)

Model	MFC-2524S	MFC-4024S	MFC-5024S	Model	MFC-80S MFLC-65K
Pump	MF-25S	MF-40S	MF-50S	Voltage	DC 24 V
Voltage (Clutch)	DC 24 V			Capacity	36 W
Capacity (Clutch)	43 W			Pulley	φ 130
Pulley	φ 136.5 (B-1)				
Net Weight (Clutch)	7.6 kg	8.8 kg	18.3 kg		
Dimensions LxWxH (mm)	272 × 160 × 205	292 × 178 × 198	408 × 203 × 223		
Packing Unit	1				

MF Series Impeller List

For "REVOLVEX PUMPS" & "RUBBER MASTER"

Spline Type Impeller

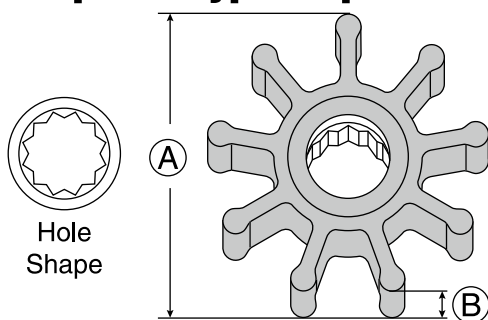

MF-25SRL (For MF-25S) (For Seawater)

Key Type Impeller

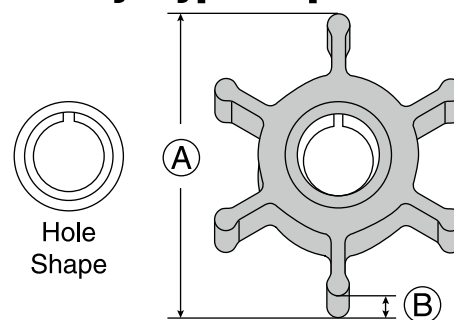

MFL-65KR (For MFL-65K, MFLC-65K) (For Seawater)

Model	MF-25S MFC-25S	MF-40S MFC-40S	MF-50S MFC-50S MFC-50SX	MFC-65K	MFL-65K MFLC-65K	MFC-80S	MF-40MS	MF-2524	MF-4024X
Application	Seawater							Oil	Seawater
Impeller Model	MF-25SRL	MF-40SRL	MF-50SRL	MF-65KR	MFL-65KR	MF-80SR	MF-40SRL	MF-2524KR MF-2524KN	MF-4024KR
(A) Outside Dia	80 mm	94 mm		128.5 mm		143 mm	94 mm	65 mm	90 mm
(B) Thickness	54 mm	63 mm	95 mm	102 mm		105.4 mm	63 mm	41 mm	46 mm
Number of Blades	9			11	6	13	9	8	
Shape of Shaft	Spline			Key		Spline		Key	
Material	Chloroprene Rubber (Neoprene)							Nitrile Butyl Rubber	Chloroprene Rubber (Neoprene)

"FS PUMPS" Marine Self-priming Pump for Seawater

- Specially designed for use with seawater.
- Pump and motor are constructed to withstand seawater and operated by a DC 24 V power source.
 1. Seawater proof motor: These motors are specially designed for seawater applications.
 2. Special aluminum compound for motor casing is made to withstand seawater corrosion. Moreover, this material does not add heavy weight to the pump.



FS-3224S

Specifications

	Model	FS-2024S	FS-3224S
PUMP	Connection Dia	20 mm (3/4")	32 mm (1 1/4")
	Connection Thread	Inner Pipe Thread	
	Total Head	9 m (30 ft)	18.5 m (60 ft)
	Delivery Volume	50 L/min (13 USG/min)	100 L/min (26 USG/min)
MOTOR	Voltage	DC 24 V	
	Rated Current	7 A	16 A
	Output	90 W / 7000 rpm	200 W / 6200 rpm
	Rating	Continuous	
	Power Cord	3 m (10 ft)	5 m (16 ft)
Standard Accessories	1 Strainer, 2 Hose Nipples, 1 Set Carbon Brush		
Gross Weight	29 kg (64 lbs)		28 kg (62 lbs)
Dimensions LxWxH (mm)	790 x 305 x 252		565 x 395 x 340
Packing Unit	5		3

Performance Curve

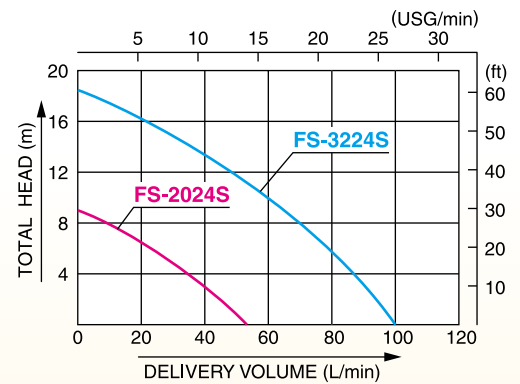

OUTLINE DRAWING

REVOLVEX PUMP

MF-40MS

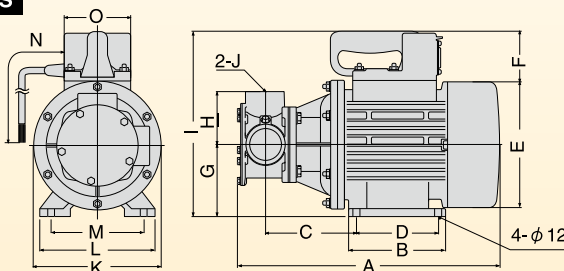

Model	A	B	C	D	E	F	G	H	I	J	K	L	M	N	O
MF-40MS	407	150	143	120	200	90	105	80	293	PS 1/2"	200	170	140	9700	120

RUBBER MASTER

MF-2524

MF-4024M

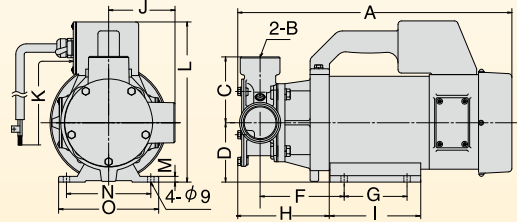

Model	A	B	C	D	E	F	G	H	I	J	K	L	M	N	O
MF-2524	281.5	PS 1"	63	60	29	119.5	66	133.5	96	63	5000	205	10	100	120
MF-4024M	394	PS 1/2"	95	75	31.5	119.5	88	131	128	95	5000	200	8	118	140

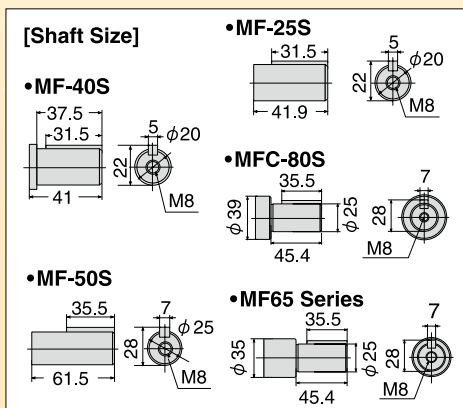

MF— MFC—

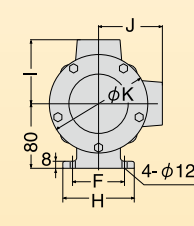

MFC-80S

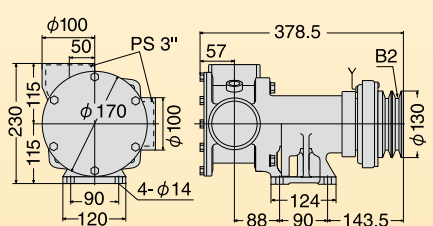

Model	A	B	C	D	E	F	G	H	I	J	K	L	M	N(Pulley)
MF-25S-MFC-2524S	PS 1"	219(234)	60	72(864)	50	60	85	85	70	108	136.5	80	B1	
MF-40S-MFC-4024S	PS 1 1/2"	232(247)	62.5	73(88)	55	60	90	90	80	123	136.5	80	B1	
MF-50S-MFC-5024S	PS 2"	311(335)	90.5	85.5(108.5)	80	80	105	105	95	123	130	91	B2	
MFL(C)-65K-MFC-65K	PS 1/2"	384(403)	105	124.5(143.5)	90	90	120	120	115	115	170	130	115	B2

Long Durability "REVOLVEX PUMP with MOTOR" & "RUBBER MASTER"

- Compact design and can be removed on the deck easily.
- Small and compact, but, large delivery volume for this class of pumps.
- They can be used continuously with motor fan.
- Dry prime pump, no need to prime with water, immediate suction.

**Easy to Remove
in The Ship**



MF-40MS

**Easy to Replace
Carbon Brushes**

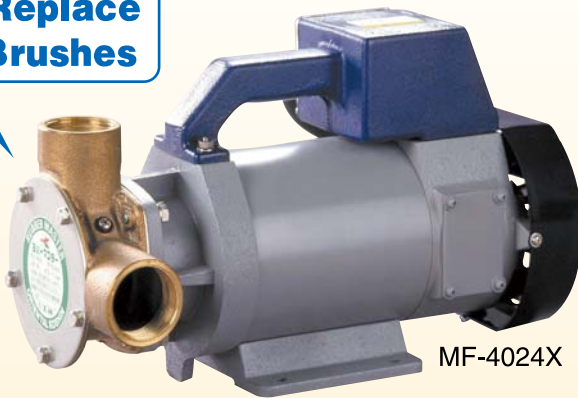
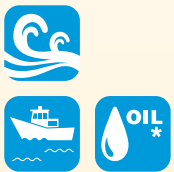

MF-4024X

* To transfer fuel, please use special impeller for oil. (Impeller type : MF-2524KN)
Please refer to page 47.

Performance Curve

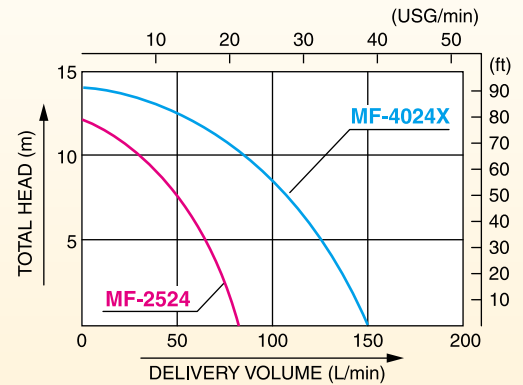
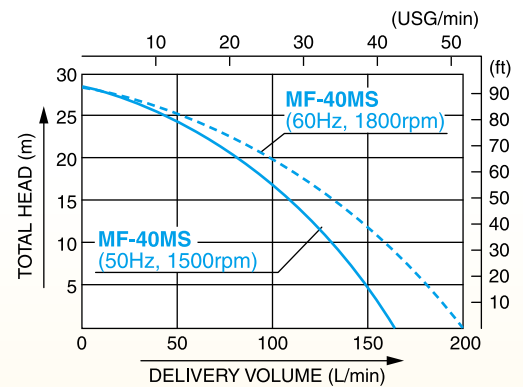

Specifications

Model	MF-40MS	MF-2524	MF-4024X	
PUMP	Connection Dia	40 mm (1½")	25 mm (1")	40 mm (1½")
	Connection Thread	Inner Pipe Thread		
	Material	Bronze Castings (Gunmetal)		
	Total Head	29 m (95 ft)	9 m (29.5 ft)	14 m (45.9 ft)
	Max. Self-Priming Head	5 m (16 ft)	3.5 m (11 ft)	
	Delivery Volume	60 Hz : 200 L/min (52 USG/min) 50 Hz : 170 L/min (44 USG/min)	80 L/min (21 USG/min)	150 L/min (39 USG/min)
MOTOR	Voltage	Three Phase 200 V		
	Current	6.8 A / 50 Hz, 6.0 A / 60 Hz	12 – 15 A	22 – 30A
	Output	1.5 kW	250 W	400 W
	Power Cord	10 m (1.25 mm ²)	5 m (2 mm ²)	5 m (3.5 mm ²)
Standard Accessories	1 Strainer, 1 Hose Band (φ48)	1 Strainer, 2 Connecting Nipples (φ25), 3 Hose Bands (φ32)		1 Strainer, 1 Hose Band (φ48)
Gross Weight	24 kg (53 lbs)	8.8 kg (19 lbs)	22 kg (48 lbs)	
Dimensions LxWxH (mm)	498 × 254 × 359	325 × 223 × 253	429 × 230 × 295	
Packing Unit		1		

PABOOL PUMP SU-

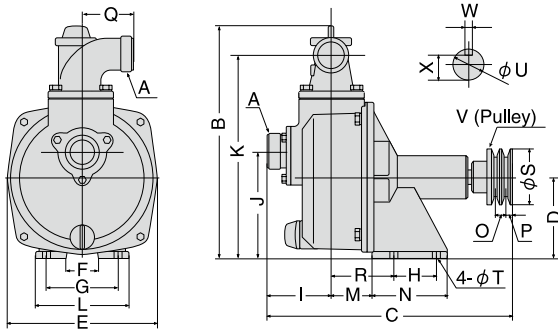

Model	A	B	C	D	E	F	G	H	I	J	K	L
SU-25Z	PS1"	274	307	90	174	90	130	45	92	121	242	150
SU-40Z	PS1½"	318	340	110	209	110	150	60	91	147	280	190
SU-50Z	PS2"	351	371	115	238	135	175	80	100	152	307	205
SU-80Z	PS3"	403	405	115	238	135	175	80	123	168	348	205
SU-40V	PS1½"	319	341	110	209	110	150	60	91	147	280	190
SU-50V	PS2"	378	371	115	238	135	175	80	100	152	337	205
SU-80V	PS3"	428	404	130	270	155	205	85	122	175	371	235

M	N	O	P	Q	R	S	T	U	W	X	V Pulley
41	90	16	9	57	71	64	9	19	5	15	2½"xA2
52	108	16	9	75	85	76	11	19	5	15	3"xA2
56	127	20	12	76	88	78	11	24	8	20	3"xB2
67	127	20	12	110	99	78	11	24	8	20	3"xB2
52	108	15	9	75	85	78	11	19	5	16	3"xA2
56	127	19	12.5	80	88	78	11	24	7	20	3"xB2
72	130	19	12.5	112	102	78	14	24	7	20	3"xB2

PONSTAR

PB-

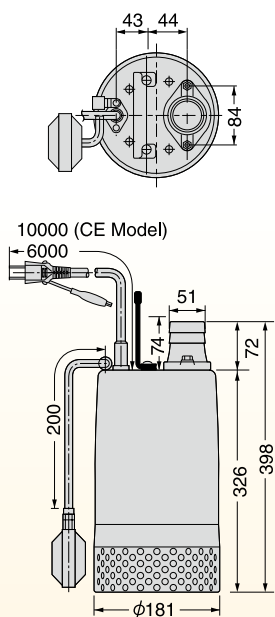

PS-

PSA-

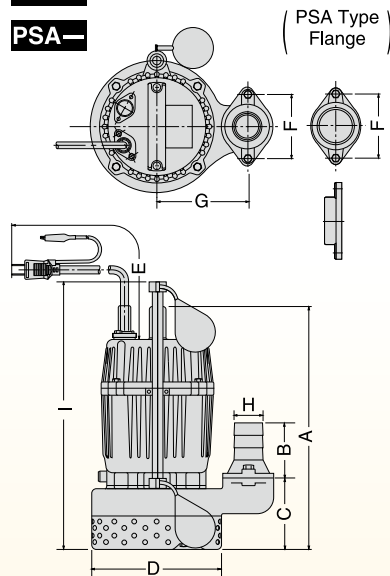

PSK-53222

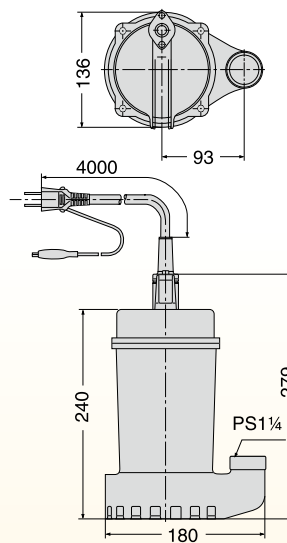

PKS-55022

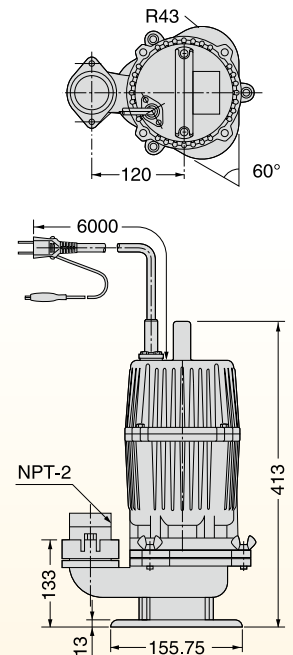

Model	A	B	C	D	E	F	G	H	I
PS•PSA-540□□•640□□	321	69	98	φ170	6000	84	120	φ39	426
PS•PSA-550□□•650□□	362	72	98	φ170	6000	84	120	φ51	426

PQ-

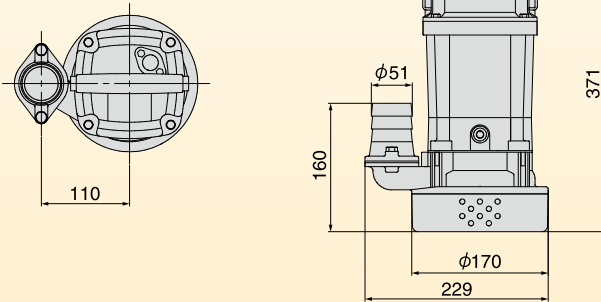

PX-

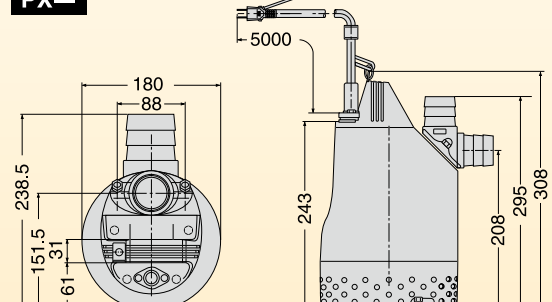

PONDY

CP-

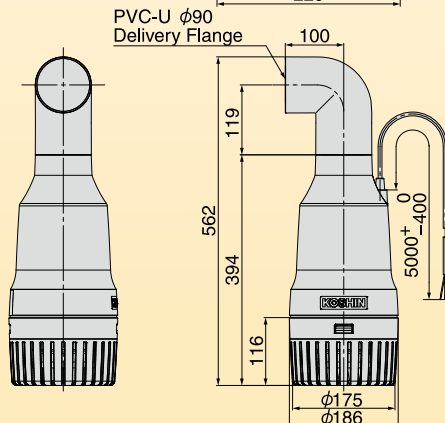

PXL-

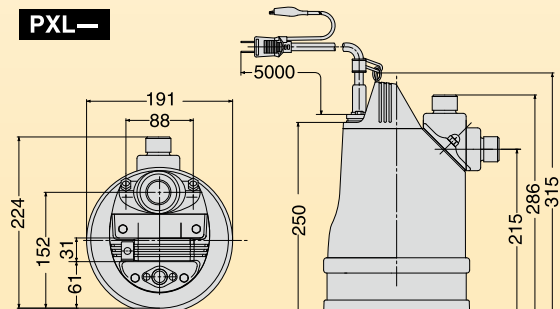

GEAR PUMP

GL—

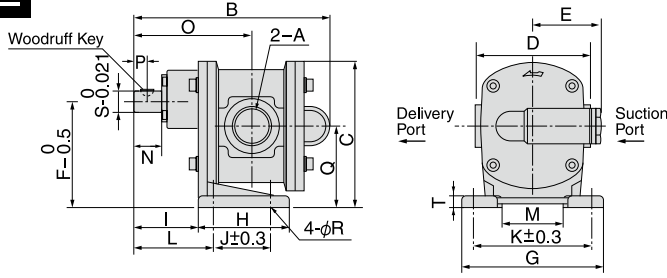

Type	A	B	C	D	E	F	G	H	I	J	K	L	M
GL-13-□	PS $\frac{1}{2}$	189	131	108	64.5	95	138	73	71	40	116	87	58
GL-20-□	PS $\frac{3}{4}$	196	131	108	64.5	95	138	73	71	40	116	87	58
GL-25-□	PS1	208	131	108	64.5	95	138	73	71	40	116	87	58
GL-32-□	PS1 $\frac{1}{4}$	222	131	108	64.5	95	138	73	71	40	116	87	58
GL-40-□	PS1 $\frac{1}{2}$	265	189	148	89.5	136	184	112	86	70	156	111	100
GL-50-□	PS2	290	189	148	89.5	136	184	112	86	70	156	111	100

N	O	P	Q	R	S	T	U
30	113	15	75	11	18	12	4x19
30	117	15	75	11	18	12	4x19
30	122	15	75	11	18	12	3x19
30	130	15	75	11	18	12	4x19
40	158	19	106	11	22	16	5x22
40	170	19	106	11	22	16	5x22

	V	W	X
GL-13-□			
GL-20-□	69	55	
GL-25-5			
GL-25-10	93	125	50
GL-32-□			
GL-40-5	93	125	50
GL-40-10	103	140	63
GL-50-5			
GL-50-10	115	160	80

GL-13-□
GL-20-□
GL-25-5



GL-25-10,
GL-32-□,
GL-40-□,
GL-50-□

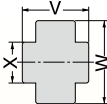

FS PUMP

FS-12D FS-24D

Cord Tip Shape

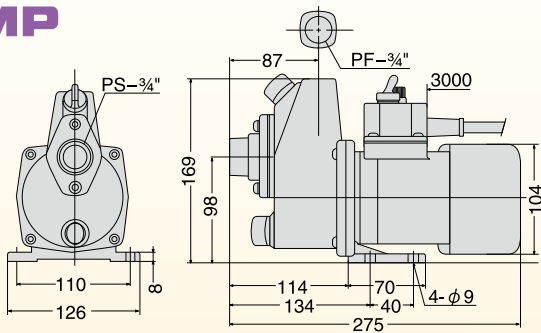
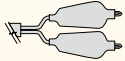

CHANGE-MASTER

GM-2524H

Cord Tip Shape

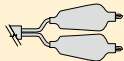

A Code Length:5000

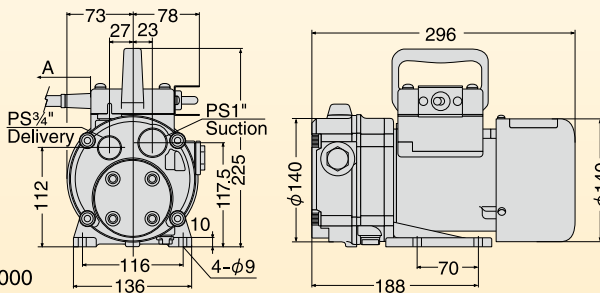

PONDY

SK-2524

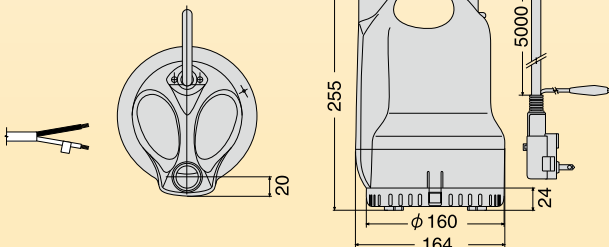

GB— GC—

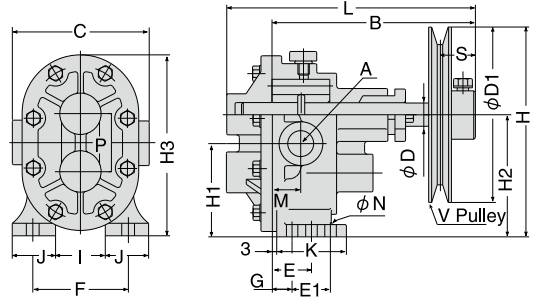

Type	A	L	B	C	D	D1	H	H1	H2	H3
GC-13/GB-13	PS $\frac{1}{2}$	181	148	100	18	127	151	67	88	130
GC-20/GB-20	PS $\frac{3}{4}$	201	165	130	20	152	179	78	103	153
GC-25/GB-25	PS1	247	204	142	22	203	230	91	129	191

F	J	I	K	E	G	E1	N	M	P	S	Pulley
70	32	36	51	33	—	—	9	21	41	25	A1
97	36	58	30	—	23	28	9	25	50	25	A1
114	38	65	75	—	30	34	10	33	63	24	A1

FILL PUMP

FR-200

Out Side Dia ϕ 37
Inside Side Dia ϕ 25

Cord Shape

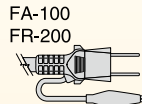
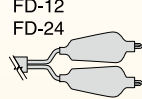

FD-12

FD-24

FA-100

Out Side Dia ϕ 28
Inside Side Dia ϕ 20

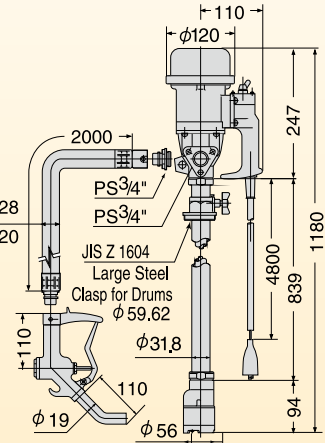
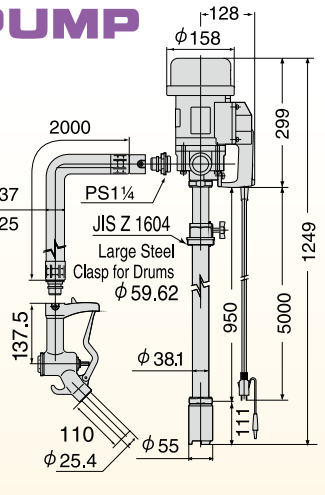

MARINE PET

BL-2512N

BL-2524N

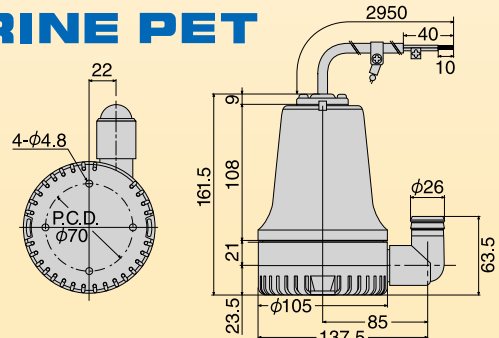

ECARL BOX

RES-330A
RES-330B

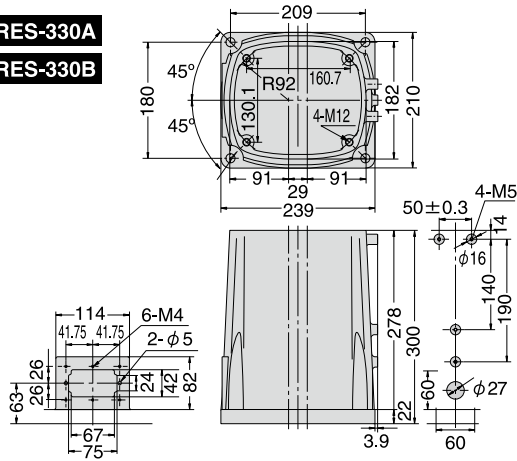

REF-300

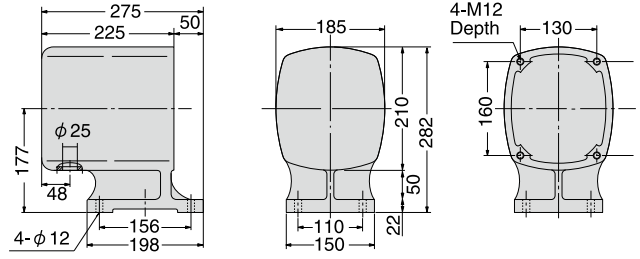

REF-330

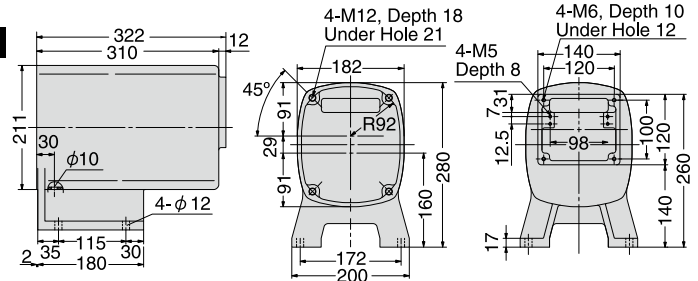

NEW BILGE KING

[Derively Nozzle]

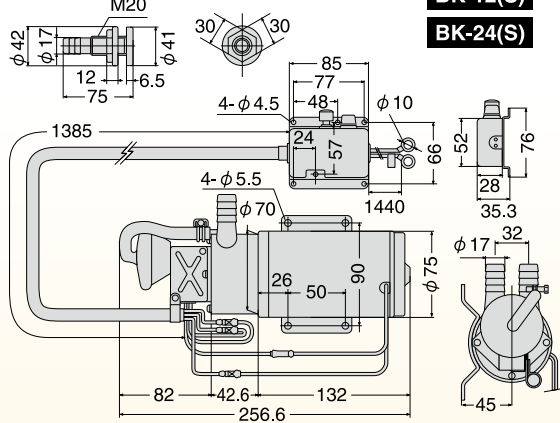

BK-12(S)
BK-24(S)

FS PUMP

FS-2024S



FS-2024S

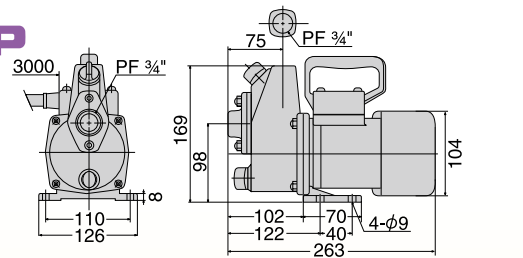

FS-3224S



FS-3224S

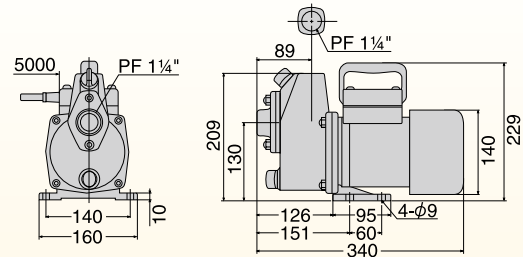

ECARL

[Shaft Size]

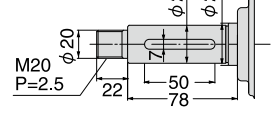

REL-5524LB

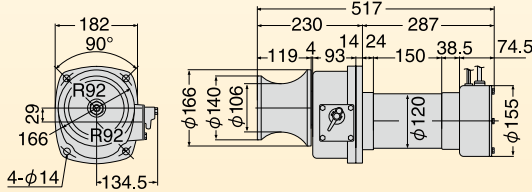

RES-5524LB

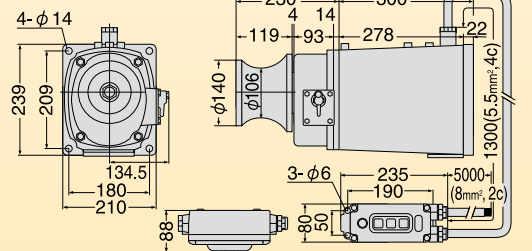

RES-2512

RES-4024(L)

RES-7524

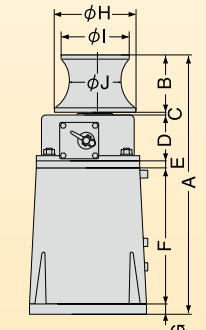
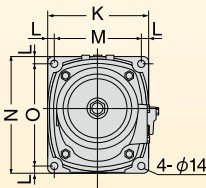

RENS-7524

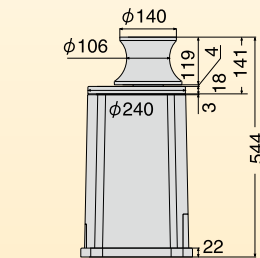
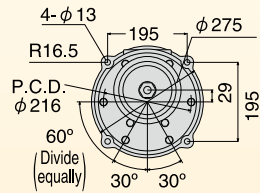

REN-7524

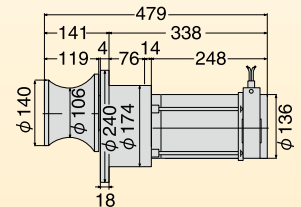
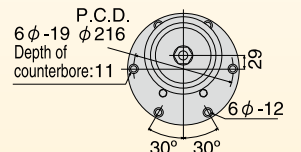

REL-2512

REL-2524

REL-4024(L)

REL-7524

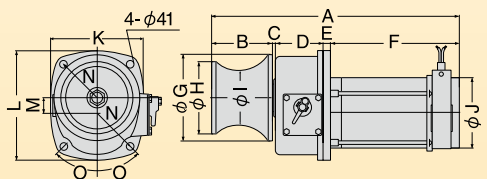

Model	A	B	C	D	E	F	G	H	I	J	K	L	M	N	O
RES-2512															
RES-4024(L)	530	119	4	93	14	278	22	166	140	106	210	15	180	239	209
RES-7524	532		6												

Model	A	B	C	D	E	F	G	H	I	J	K	L	M	N	O
REL-2512(L)	427					197				113	182				
REL-2524		119	4	93	14	203	166	140	106		136	211	29	R92	45°
REL-4024(L)	433					248				136	182				
REL-7524	480		6												

KOSHIN LTD.

Headquarters: Kyoto, Japan
(Mother factory)
Established: 1948
Business: Production and R & D, Sales of pumps, Sprayers, Winches
Employee: 190
Overseas factory: • KOSHIN LITIAN (NINGBO) CO.,LTD.
• NINGBO KOSHIN MOTER CO.,LTD.
• KOSHIN THAILAND CO.,LTD.
Overseas office: • KOSHIN AMERICA CORP. (Chicago)
Representative offices: • EUROPE OFFICE
• MEXICO OFFICE



President T. Kohara



Die-cast trimming robot



Assembling line



Head office and factory

KOSHIN LITIAN PUMP (NINGBO) CO., LTD.

Address: Ningbo, China
Established: 2003
Business: Production of Submersible pumps, Sprayers, Kerosene pumps, Siphon pumps, Bath pumps
Employee: 380



Factory facility

NINGBO KOSHIN MOTOR CO., LTD.

Address : Ningbo, China
Established: 2010
Business: Production of Electric motors, and Submersible pumps
Employee 14



Motor factory

KOSHIN (THAILAND) CO., LTD.

Address : Bangkok, Thailand
Established: 2006
Business: Production of Hidels pumps, and Submersible pumps
Employee 100



Exterior

KOSHIN

KOSHIN LTD.

12 Kami-Hachinotsubo Kotari,
Nagaokakyo City, Kyoto 617-8511 JAPAN
TEL. +81-75-954-6111 FAX. +81-75-954-6119
www.koshinpump.com

*Design and specifications are subject to change without notice.

13-01 699705102

