

Nyva Series

HYDRAULIC DIAPHRAGM METERING PUMPS



innovation > technology > future

Nyva Series

Hydraulic diaphragm metering pumps

A line hydraulic diaphragm metering pumps designed according to the **API 675 Standards**.

The possibility of construction with various materials allows these metering pumps to satisfy every liquid dosing and mixing application.

Furthermore, their complete compliance with the **ATEX Standards** even allows these pumps to be installed in dangerous areas.



Mechanisms

Mechanical return type available in several sizes.

Main features:

- Internal worm gearbox, oil bath lubricated with low noise emissions
- Rotating parts on bearings to minimise power consumption
- High precision stroke adjustment, both manual and via electric actuator



for zone 1 and zone 2

Hydraulic diaphragm heads

The ideal solution for applications requiring high levels of operational safety and reliability

- Zero leakage; hermetic construction for dosing toxic, corrosive and other unsafe liquids, for which the absence of leaks is fundamental
- Protection against external pollutants which could contaminate the liquid being pumped
- Flexibility of use; the PTFE diaphragms are compatible with a huge liquid range

Mechanical refilling system

It maintains a hydraulic fluid constant level, thereby guaranteeing maximum precision and repeatability. It keeps also under control the deformation of diaphragm thereby increasing its duration.

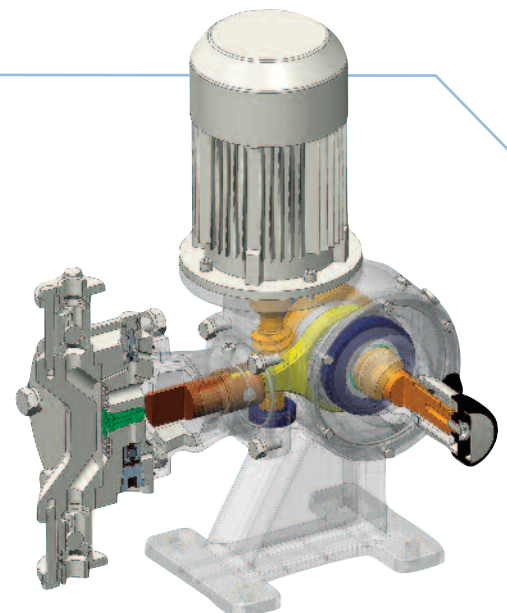

On demand double diaphragm with rupture detector

In case of breaking of one of the two diaphragms, the detector activates either a local visual alarm or a pressure switch. The second diaphragm ensures the continued operation of the pump. Allowing scheduled maintenance.





Venting system

Aside from guaranteeing automatic venting during operation, the venting system also facilitates the pump priming by favouring the air purge by means of a manual action.



Pressure relief valve

It protects the pump against unexpected overpressure.



Cartridge valves

In order to ensure maximum dosing precision, even for small flow rates, double and triple ball configurations are available with high precision seats. The metal gaskets for the AISI 316L stainless steel heads, and the FPM gaskets for those in plastic, guarantee maximum compatibility.



Flow Rate adjustment

- Easy to handle knob with high visibility nonius for the best flow adjustment.
- Optionally automatic variation by electrical actuators **AKTUA**.

The electrical actuators **AKTUA** were designed to replace the pump manual adjusting device of the flow, with an automatic system remotely controllable, which acts on the length of the pump stroke directly in the field.

- Internal display 4-digit, 7-segment display.
- Calibration can also be executed with system running.
- Available in standard version for installation in areas not classified, or ATEX compliant for installation in dangerous areas.



Applications

Water treatment and Industrial sectors

- Municipalities
- Wastewater
- Chemical
- Food & Beverages
- Detergents
- Power Generation
- Environment
- Petrochemical
- Pharmaceutical
- Paper
- Textile

Technical Features

Pressure

- up to 124 bar

Flow Rate

- up to 660 L/h

Temperature

- Ambient: from -5 °C to 40 °C
- Fluid: from -5 °C to 50 °C

Contact materials

- AISI 316L; PP; PVDF; PVC

Accessories

- Flow rate calibration pots
- Pulsation dampers
- Safety valves
- Back pressure valves

A Worldwide Group at your service

seko is an International Group, developing, manufacturing and delivering its products in more than 50 countries, through its subsidiaries and an extended network of distributors, agents and authorized dealers.

seko is a leading manufacturer of dosing pumps and dosing systems with more than 40 years experience. This long activity allowed **seko** to acquire a vast experience in diversified applications and to confirm its international success in many industrial fields through the supply of reliable solutions for the dosing, injection and transfer of liquids.



BRAZIL

■ **Seko do Brasil Comercio de Sistemas de Dosagem Limitada**
03170-050 São Paulo (SP)
sekobrasil@sekobrasil.com.br
www.sekobrasil.com.br

BENELUX

■ **Seko Benelux B.V.**
7532 SK Enschede
(The Netherlands)
info@sekobenelux.com

CHINA

■ **Seko China Ltd**
072750 Hebei
china@seko.com
www.sekochina.com

DENMARK

■ **Seko Denmark**
DK-4930 Maribo
info@seko.com

FRANCE

■ **Seko Lefranc-Bosi S.A.**
77435 - Marne La Vallée
Cedex 2
lefrancbosi@lefrancbosi.com
service.commercial@seko.fr
www.lefrancbosi.com

GERMANY

■ **Seko Deutschland GmbH**
55252 Mainz - Kastel
info@seko-messtechnik.de
www.seko-germany.com

ITALY

■ **Seko Spa**
02010 S.Rufina - Rieti
sales@seko.com

ITALY

■ **Seko Spa [Process & Sytems]**
20068 Peschiera Borromeo - Milano
info.psd@seko.com
info@seko.com

ROMANIA

■ **Seko Sieta S.r.l.**
400393 Cluj-Napoca
info.dpro@seko.com

RUSSIA

■ **OOO Seko**
129347 - Moscow
sekorussia@seko.com
www.sekorussia.ru

SINGAPORE

■ **Seko Dosing Systems Asia Pacific Pte Ltd**
608838 Singapore
asiapacific@seko.com

SOUTH AFRICA

■ **Seko Southern Africa (PTY) Ltd**
Kyasand - Johannesburg - Gauteng
sales@sekosa.co.za

SPAIN

■ **Seko Ibérica Sistemas de Dosificación S.A.**
08960 Sant Just Desvern - Barcelona
sekoiberica@sekoiberica.com

SWEDEN

■ **Seko Sweden**
26123 Landskrona
info@seko.com

TURKEY

■ **Seko Endüstriyel Pompalar ve Proses Sistemleri San. ve Tic. Ltd. Şti.**
Kartal Istanbul
info@seko.com.tr
www.seko.com.tr

UNITED ARAB EMIRATES

■ **Seko Middle East FZE**
P.O. Box 42090 - Hamriyah Free Zone, Sharjah
info@seko.ae
sales@seko.ae

UNITED KINGDOM

■ **Seko UK Chemical Controls Ltd**
Harlow, Essex - CM19 5JH
seko.uk@seko.com
www.sekouk.com

USA

■ **Seko Dosing Systems Corporation**
Tullytown - PA 19007
sales@sekousa.com
www.sekousa.com

For more information
www.seko.com

