



SINCE 1976

修耐電機



ISO 9001
BSMI

標檢局

ISO-9001/CNS 12681

CVO-
不銹鋼耐蝕用

SQ-
不銹鋼污水用

SSQ-
不銹鋼污物用

KHQ-
不銹鋼污水用

CVO

Stainless Volute Pump

SQ

Stainless Sump Pump

SSQ

Stainless Sewage Pump

KHQ

Stainless Sump Pump



CVQ 1/2HP~15HP
SCS 13.14(#304.316)

SHOWFOU CHEMICAL PUMP

不銹鋼耐蝕用 ~SCS 13(#304) · SCS 14(#316)

- Submersible Stainless Chemical Pump~SCS 13(#304)
- Centrifugal Stainless Chemical Pump~SCS 13,14(#304,316)
- Mechanical Seal--Teflon & Viton ·

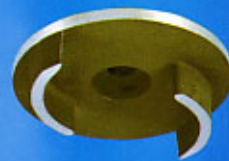
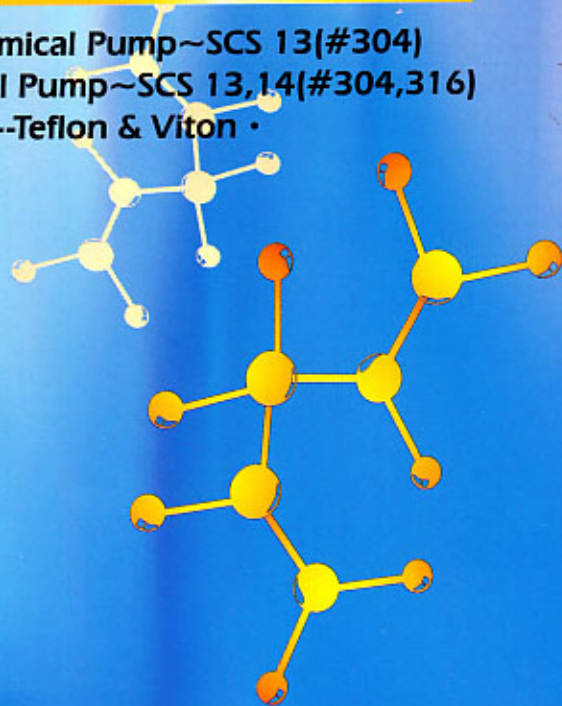
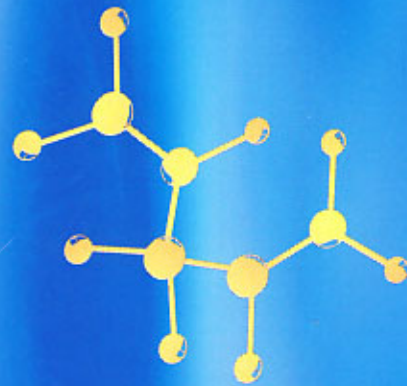

SQ 1/2HP~1HP
SCS 13(#304)



SSQ 1HP~5HP
SCS 13(#304)



KHQ 2HP~10HP
SCS 13(#304)

● CVO-Centrifugal stainless volute pump ~SCS 13,14 (#304,316)

CVO

■ FEATURES:

- Extra long life design, since the pump body and all related parts are made of casting stainless SCS 13(#304) or SCS 14(#316), these will have the capability of anti-acid & alkali; and also suitable for using in sea water.
- Since impeller is adjusted with a dynamic balancing there are little vibration and noise and an extraordinary durability is ensured.

■ APPLICATIONS:

- The pumps are applicable in the following industries: Chemistry, heavy-chemistry, medicines, photograph, dyeing, bleaching, food, fishery, drinks, brewing, oil and fat, fiber, oil refining, cosmetic, metal treatment and electro-plating.
- For a member of plant for preventing pollution, sewage and drainage treatment, washing plant, dust collecting plant and clean air plant.

■ PERFORMANCE CURVE :

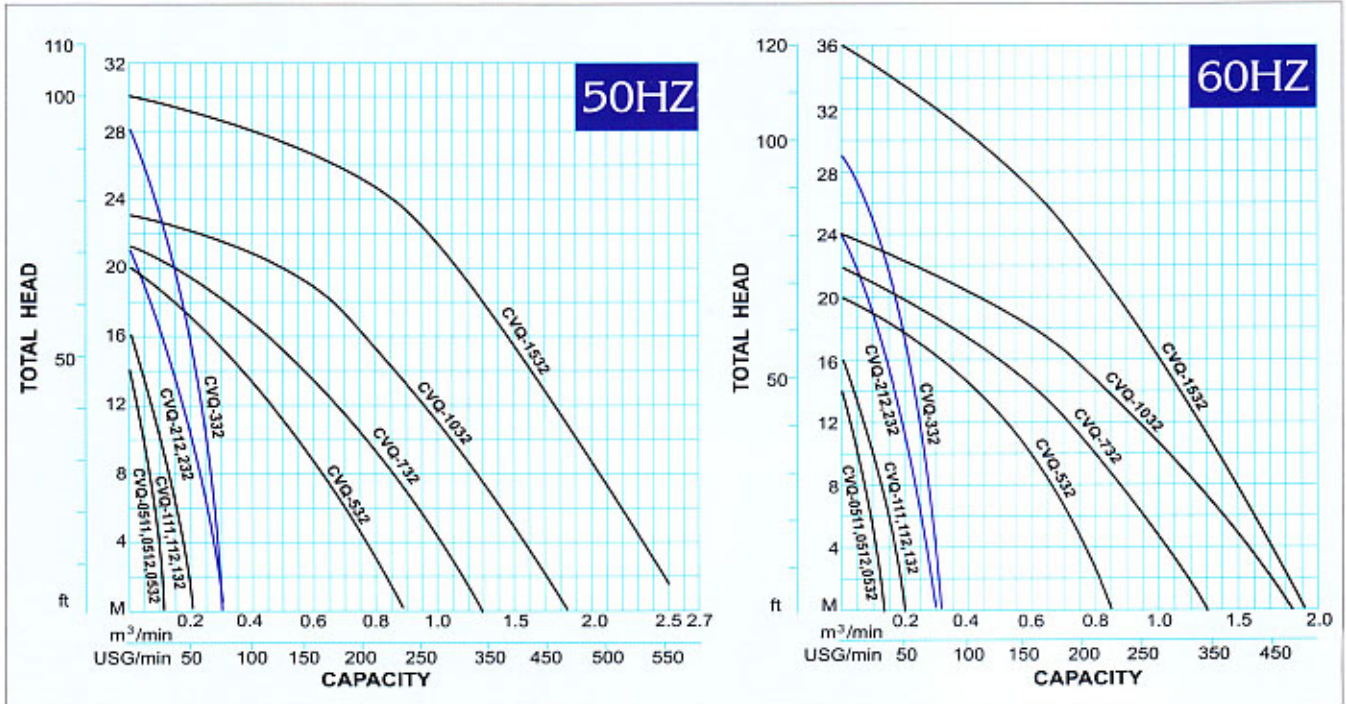

■ SPECIFICATIONS:

■ DIMENSIONS:

型式 TYPE	電動機 MOTOR				抽水機 PUMP								重量 Weight KG	尺寸 SIZE						
	Power		Phase PH	Volt V	Disch. Dia. Inch mm	Total Head		Total Flow		Max. Head		Max. Flow		A	B	C	D	E		
	HP	KW				50HZ	60HZ	50HZ	60HZ	50HZ	60HZ	50HZ							60HZ	
CVO-0512	1/2	0.4	1	110/220	1"	25	8	9	0.07	0.06	14	14	0.11	0.13	20	260	75	100	220	355
CVO-0532			3	220-440			8	9	0.07	0.06	14	14	0.11	0.13						
CVO-111	1	0.75	1	110/220	1 1/2"	40	10	8.7	0.10	0.14	16	16	0.21	0.19	22	290	75	115	250	390
CVO-132			3	220-440												10	8.7	0.10	0.14	16
CVO-212	2	1.5	1	110/220	2"	50	14	14	0.12	0.17	21	24	0.29	0.29	31	325	90	125	290	445
CVO-232			3	220-440												14	14	0.12	0.17	21
CVO-332	3	2.2	3	220-440	2"	50	12	16	0.17	0.20	28	29	0.30	0.31	40	310	90	125	290	445
CVO-532			3	220-440												12	16	0.17	0.20	28
CVO-732	7 1/2	5.5	3	220-440	4"	100	11.3	12	0.98	0.92	21	22	1.31	1.30	73	405	125	145	345	540
CVO-1032			3	220-440												11.3	12	0.98	0.92	21
CVO-1532	15	11	3	220-440	4"	100	17.9	24	1.68	1.25	30	36	2.5	1.91	118	430	125	165	370	585

- PUMP CONSTRUCTION IS MADE OF CASTING STAINLESS.
- BOTH SCS 13 (#304) AND SCS 14 (#316) ARE AVAILABLE UPON REQUEST.

■ CONSTRUCTIONS:

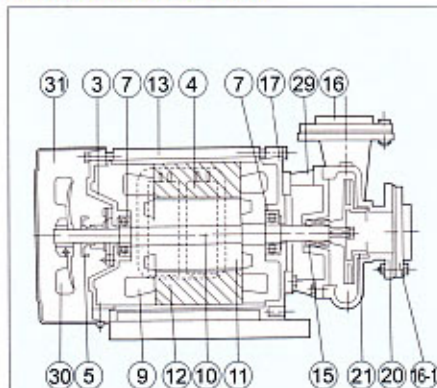

ITEM NO.	PARTS LIST	MATERIAL
3	Motor Head Cover	Cast Iron
4	Condenser	1φ only
5	Centrifugal Switch	1φ only
7	Upper Ball Bearing	
9	Coil	
10	Shaft	Stainless Steel
11	Rotor	Steel Plate
12	Stator	Steel Plate
13	Motor Casing	Cast Iron
15	Mechanical Seal	Teflon-Viton
16	Flange Setter	Stainless Steel Casting
17	Motor Lower Cover	Cast Iron
20	Pump Casing	Stainless Steel Casting
21	Impeller	Stainless Steel Casting
29	Pump Bracket	Stainless Steel Casting
30	Cooling Fan	Plastic
31	Fan Cover	Steel

PS: STAINLESS STEEL CASTING: BOTH SCS13(#304) AND SCS14(#316) ARE AVAILABLE UPON REQUEST.

■ DIMENSIONS:

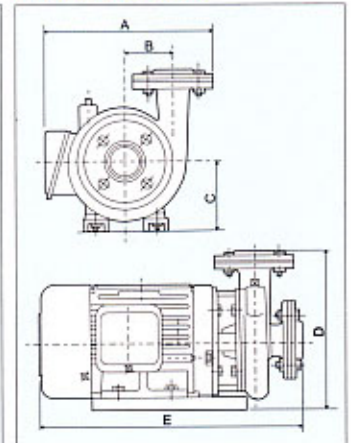

- SQ.KHQ -Submersible stainless sump pump~SCS 13 (#304)
- SSO -Submersible stainless sewage pump~SCS 13 (#304)

SQ/SSQ/KHQ

■ FEATURES:

- Extra long life design, since the pump body and all related parts are made of casting stainless SCS 13(#304), these will have the capability of anti-acid & alkali; and also suitable for using in sea water.
- Equipped with double mechanical seals, together with anti-corrosion viton so as to make up these special assemblies.
- Impeller was balancing processed, this vibration free advantage brings the pump and motor superior servicing life.

■ PERFORMANCE CURVE :

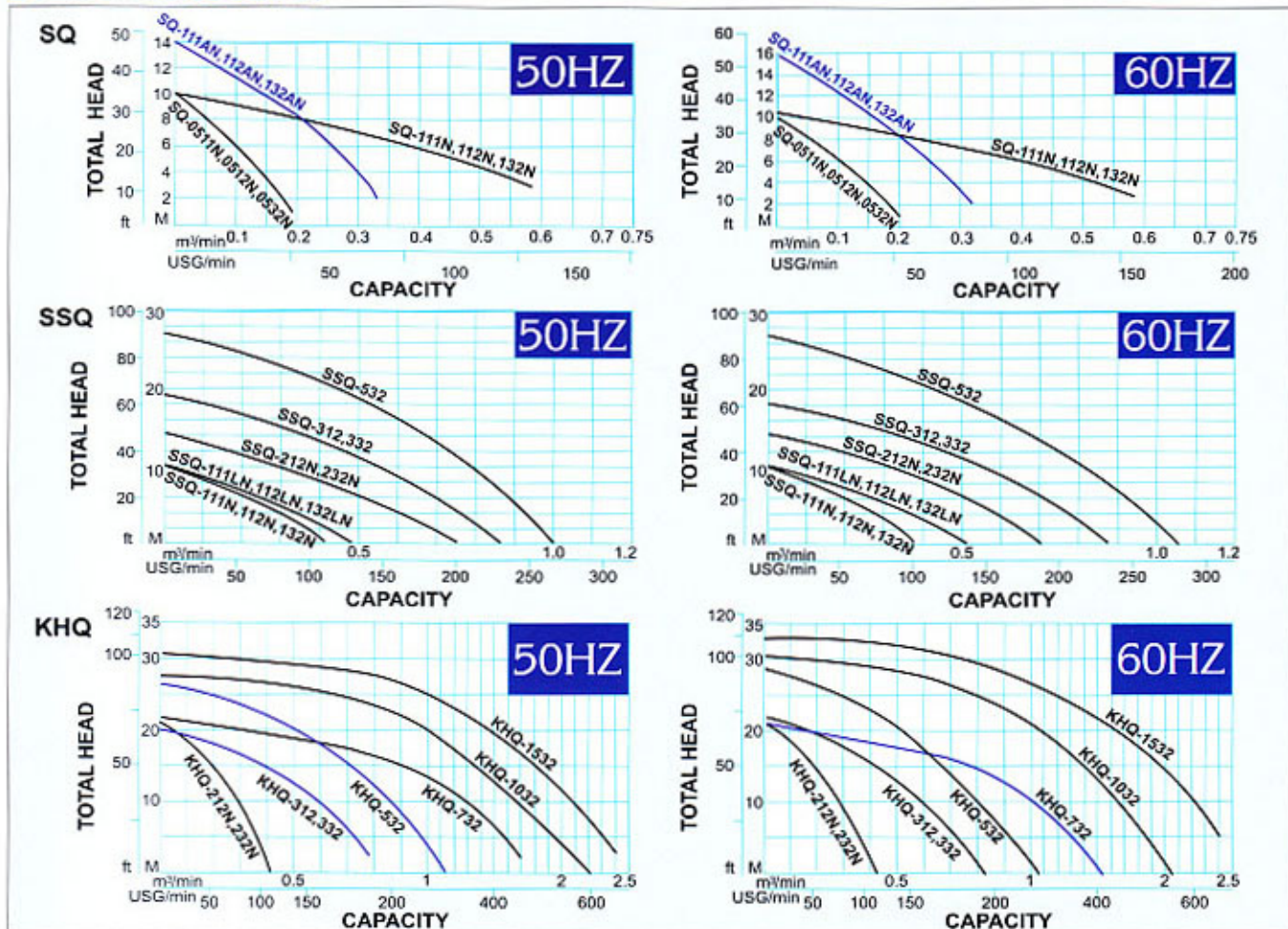

■ APPLICATIONS:

- The pumps are applicable in the following industries: Chemistry, heavy-chemistry, medicines, photograph, dyeing, bleaching, food, fishery, drinks, brewing, oil and fat, oil refining, cosmetic, fiber, metal treatment and electro-plating.
- For a member of plant for preventing pollution, sewage and drainage treatment, washing plant, dust collecting plant and clean air plant.

■ SPECIFICATIONS:

■ DIMENSIONS:

型式 TYPE	電動機 MOTOR			抽水機 PUMP								電纜 Cable	重量 Weight	尺寸 SIZE									
	Power HP	Phase KW	Phase PH	Voltage Volt	Disch. Dia. Inch	Total Head		Total Flow		Max. Head				Max. Flow		A	B	C	D	E	F		
						50HZ	60HZ	50HZ	60HZ	50HZ	60HZ			50HZ	60HZ								
SQ-0511N	1/2	0.4	1	110	2'	50	7	6	0.08	0.10	10	10	0.21	0.21	1.25 ² x6	11	230	120	160	165	80	415	
SQ-0512N			3	220-440																			
SQ-0532N			3	220-440																			
SQ-111AN	1	0.75	1	110	2'	50	8.3	10.1	0.20	0.16	14	16	0.36	0.36	2 ² x6	21	265	130	190	180	85	460	
SQ-112AN			3	220-440																			
SQ-132AN			3	220-440																			
SQ-111N	1	0.75	1	110	3'	80	6.2	6.2	0.38	0.39	10	10.5	0.71	0.72	2 ² x6	24	300	150	190	240	125	505	
SQ-112N			3	220-440																			
SQ-132N			3	220-440																			
SSQ-111N	1	0.75	1	110	2'	50	6.1	6.2	0.28	0.20	10	10	0.41	0.38	2 ² x6	22	290	135	225	205	115	495	
SSQ-112N			3	220-440																			
SSQ-132N			3	220-440																			
SSQ-111LN	1	0.75	1	110	3'	80	5	6.5	0.33	0.27	10	10	0.48	0.5	2 ² x6	24	320	150	225	235	118	500	
SSQ-112LN			3	220-440																			
SSQ-132LN			3	220-440																			
SSQ-212N	2	1.5	1	220	3'	80	7.4	8.9	0.48	0.49	14	14	0.75	0.7	3.5 ² x10	36	355	165	265	260	140	550	
SSQ-232N			3	220-440																			
SSQ-312	3	2.2	1	220	4'	100	11	10	0.40	0.41	19	18	0.86	0.87	3.5 ² x10	53	410	192	265	290	140	580	
SSQ-332			3	220-440																			
SSQ-532	5	3.7	3	220-440	4'	100	14.2	16	0.51	0.49	27	27	1.0	1.05	3.5 ² x10	49	410	192	265	290	140	500	
KHQ-212N	2	1.5	1	220	2'	50	11.5	12.3	0.21	0.21	20	21	0.41	0.41	3.5 ² x10	37	228	80	460				
KHQ-232N			3	220-440																			
KHQ-312			1	220																			
KHQ-332	3	2.2	3	220-440	3'	80	10.2	12.2	0.46	0.50	20	22	0.8	0.82	3.5 ² x10	40	228	80	570				
KHQ-532			3	220-440																			
KHQ-732	7	5.5	3	220-440	4'	100	12.8	12.3	1.08	1.04	22	21	1.7	1.51	5.5 ² x10	70	232	125	720				
KHQ-1032	10	7.5	3	220-440	6'	150	19.3	16.7	1.33	1.39	27	30	2.2	2.1	5.5 ² x10	78	272	125	665				
KHQ-1532	15	11	3	220-440	6'	150	17.7	19.6	1.45	1.64	30	32	2.4	2.4	8 ² x10	115	335	200	785				

- PUMP CONSTRUCTION IS MADE OF CASTING STAINLESS.
- ONLY SCS13 (#304) IS AVAILABLE.

■ DIMENSIONS:

■ CONSTRUCTIONS:

SQ

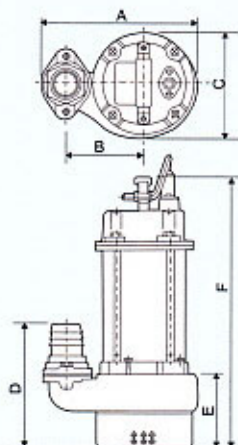

SQ

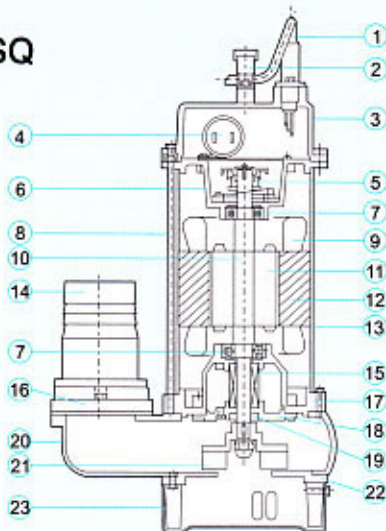

ITEM NO.	PARTS LIST	MATERIAL
1	Cable	V. C. T.
2	Handle	Stainless Steel (#304)
3	Motor Head Cover	Stainless Steel Casting
4	Condenser	1 ϕ only
5	Centrifugal Switch	1 ϕ only
6	Upper Bracket	Stainless Steel Casting
7	Upper Ball Bearing	
8	Bolt	Stainless Steel
9	Coil	
10	Shaft	Stainless Steel
11	Rotor	Steel Plate
12	Stator	Steel Plate
13	Motor Casing	Stainless Steel (#304)
14	Hose Coupling	Plastic
15	Mechanical Seal	Silicon Carbide + Viton
16	Flange Setter	Stainless Steel Casting
17	Motor Lower Cover	Stainless Steel Casting
18	Mechanical Seal Cover	Stainless Steel Casting
19	Oil Seal	Viton
20	Pump Casing	Stainless Steel Casting
21	Impeller	Stainless Steel Casting
22	Suction Cover	Stainless Steel Casting
23	Strainer	Stainless Steel

P S: Stainless Steel Casting : SCS 13 (#304)

SSQ

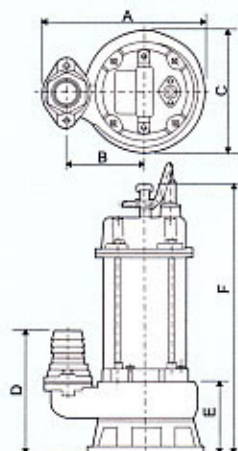

SSQ

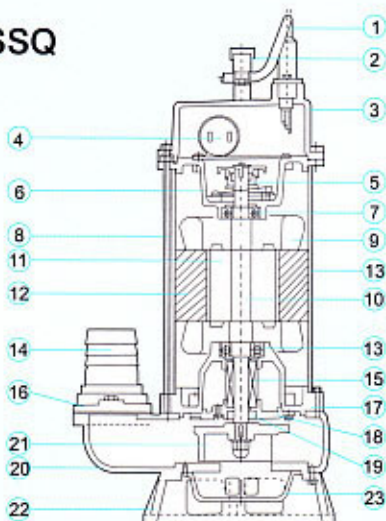

ITEM NO.	PARTS LIST	MATERIAL
1	Cable	V. C. T.
2	Handle	Stainless Steel (#304)
3	Motor Head Cover	Stainless Steel Casting
4	Condenser	1 ϕ only
5	Centrifugal Switch	1 ϕ only
6	Upper Bracket	Stainless Steel Casting
7	Upper Ball Bearing	
8	Bolt	Stainless Steel
9	Coil	
10	Shaft	Stainless Steel
11	Rotor	Steel Plate
12	Stator	Steel Plate
13	Motor Casing	Stainless Steel (#304)
14	Hose Coupling	2" -Plastic
15	Mechanical Seal	Silicon Carbide + Viton
16	Flange Setter	Stainless Steel Casting
17	Motor Lower Cover	Stainless Steel Casting
18	Mechanical Seal Cover	Stainless Steel Casting
19	Oil Seal	Viton
20	Pump Casing	Stainless Steel Casting
21	Impeller	Stainless Steel Casting
22	Suction Cover	Stainless Steel Casting
23	Strainer	Plastic

P S: Stainless Steel Casting : SCS 13 (#304)

KHQ

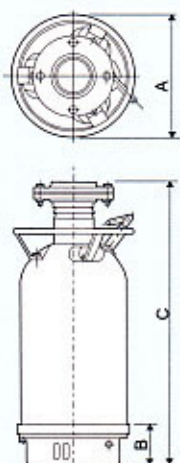

KHQ

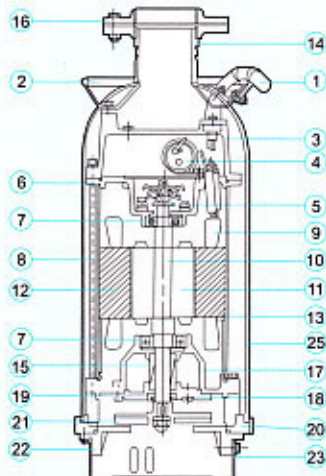

ITEM NO.	PARTS LIST	MATERIAL
1	Cable	V. C. T.
2	Handle	Stainless Steel (#304)
3	Motor Head Cover	Stainless Steel Casting
4	Condenser	1 ϕ only
5	Centrifugal Switch	1 ϕ only
6	Upper Bracket	Stainless Steel Casting
7	Upper Ball Bearing	
8	Bolt	Stainless Steel
9	Coil	
10	Shaft	Stainless Steel
11	Rotor	Steel Plate
12	Stator	Steel Plate
13	Motor Casing	Stainless Steel (#304)
14	Hose Coupling	Stainless Steel Casting
15	Mechanical Seal	Silicon Carbide + Viton
16	Flange Setter	Stainless Steel Casting
17	Motor Lower Cover	Stainless Steel Casting
18	Mechanical Seal Cover	Stainless Steel Casting
19	Oil Seal	Viton
20	Pump Casing	Stainless Steel Casting
21	Impeller	Stainless Steel Casting
22	Suction Cover	Stainless Steel Casting
23	Strainer	Stainless Steel (#304)
25	Outer Cover	Stainless Steel (#304)

P S: Stainless Steel Casting : SCS 13 (#304)

PT. LUKES INDONESIA

Lindeteves Trade Center Lt UG, Blok B1 No. 6
 Jalan Hayam Wuruk, Jakarta - Indonesia
 Phone : 021 - 6231 7842, 628 5144
 Fax : 021 - 6231 0499
 email : sales@lukesindeonesia.com



All specifications subject to change without notice.