

● CVQ-Centrifugal stainless volute pump ~SCS 13,14 (#304,316)

■ CONSTRUCTIONS:

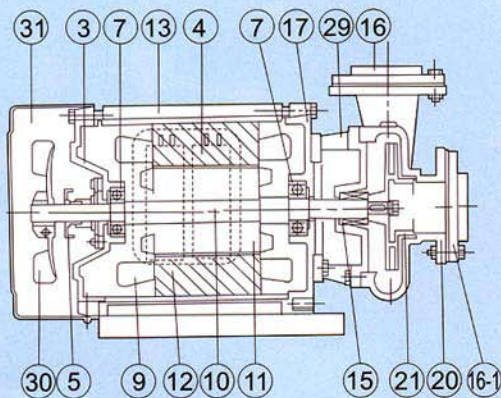

ITEM NO.	PARTS LIST	MATERIAL
3	Motor Head Cover	Cast Iron
4	Condenser	
5	Centrifugal Switch	
7	Upper Ball Bearing	
9	Coil	
10	Shaft	Stainless Steel
11	Rotor	Steel Plate
12	Stator	Steel Plate
13	Motor Casing	Cast Iron
15	Mechanical Seal	Teflon-Viton
16	Flange Setter	Stainless Steel Casting
17	Motor Lower Cover	Cast Iron
20	Pump Casing	Stainless Steel Casting
21	Impeller	Stainless Steel Casting
29	Pump Bracket	Stainless Steel Casting
30	Cooling Fan	Plastic
31	Fan Cover	Plastic

■ PERFORMANCE CURVE 50/60Hz:

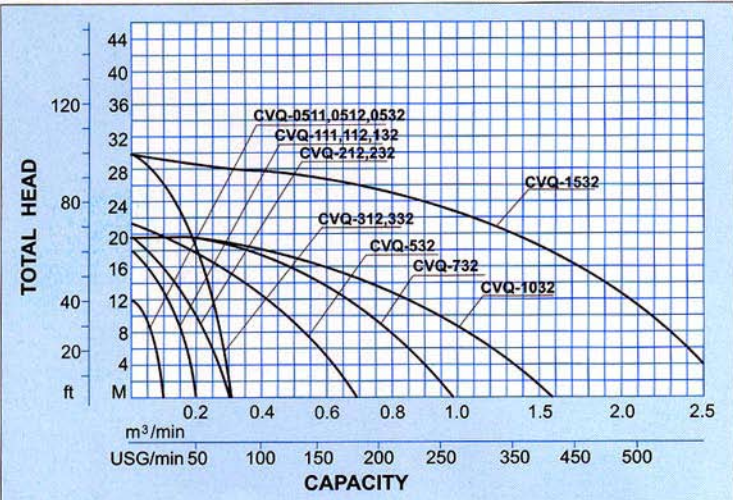

■ DIMENSIONS:

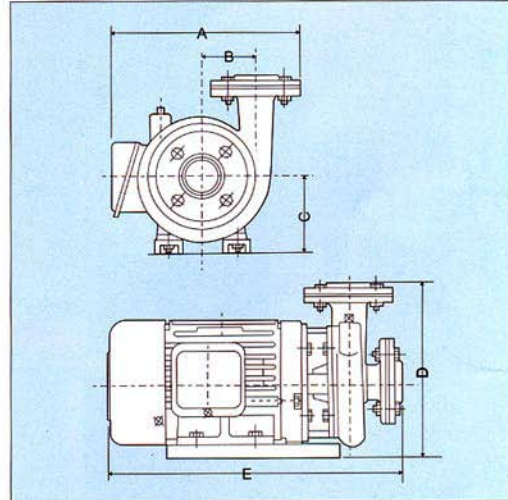

■ SPECIFICATIONS:

型式 TYPE	電動機 MOTOR			抽水機 PUMP			電纜 Cable	重量 Weight	尺寸 SIZE					
	Power	Phase	Volt	Disch. Dia.	Max. Head	Max. Flow			A	B	C	D	E	F
	KW(HP)	PH	V	inch(mm)	M	M <sup>3</sup> /MIN			mm	mm	mm	mm	mm	mm
CVQ-0512	0.4(1/2)	1	110/220	1" (25)	13	0.08	20	260	75	100	220	355		
CVQ-0532		3	220-440											
CVQ-112	0.75(1)	1	110/220	1 1/2" (40)	18	0.16	22	290	75	115	250	390		
CVQ-132		3	220-440											
CVQ-212	1.5(2)	1	110/220	2" (50)	20	0.30	31	325	90	125	290	445		
CVQ-232		3	220-440											
CVQ-332	2.2(3)	3	220-440	2" (50)	30	0.30	40	310	90	125	290	445		
CVQ-532	3.7(5)	3	220-440	3" (75)	22	0.70	59	350	100	135	305	506		
CVQ-732	5.5(7 1/2)	3	220-440	4" (100)	20	1.0	73	405	125	145	345	540		
CVQ-1032	7.5(10)	3	220-440	4" (100)	23	1.8	88	410	125	165	370	585		
CVQ-1532	11(15)	3	220-440	5" (125)	30	2.5	118	430	125	165	370	585		

■ DIMENSIONS: